

# Dival 700

Medium-low pressure gas regulator



Revision C - Edition 12/2024

**USE, MAINTENANCE  
AND WARNING  
MANUAL**



# 1 - INTRODUCTION

## FOREWORD

All rights reserved. No part of this publication may be reproduced, distributed, translated into other languages or transmitted by any electronic or mechanical media, including photocopies, recording or any other storage and retrieval system, for any other purposes that are not exclusively the personal use of the buyer, without the express written permission of the Manufacturer.

The manufacturer is in no way responsible for the consequences of operations carried out in a manner not in accordance with the manual.

## GENERAL REMARKS

All operating, maintenance instructions and recommendations described in this manual must be observed. In order to obtain the best performance and to keep the equipment in efficient condition, the manufacturer recommends that maintenance operations be carried out regularly.

It is of particular importance that the personnel responsible for the equipment be trained in its use, maintenance and application of the safety instructions and procedures indicated in this manual.

**COPYRIGHT 2024**

**© PIETRO FIORENTINI S.P.A.**



## 1.1 - REVISION HISTORY

Revision index	Date
<b>A</b>	03/2023
<b>B</b>	11/2024
<b>C</b>	12/2024

Tab. 1.1

# INDEX

<b>1 - INTRODUCTION .....</b>	<b>3</b>
1.1 - REVISION HISTORY.....	5
<b>2 - GENERAL INFORMATION .....</b>	<b>11</b>
2.1 - MANUFACTURER IDENTIFICATION .....	11
2.2 - IDENTIFICATION OF THE PRODUCT .....	11
2.3 - REGULATORY FRAMEWORK.....	11
2.4 - WARRANTY .....	11
2.5 - SYMBOLS USED IN THE MANUAL.....	12
2.6 - ADDRESSEES, SUPPLY AND STORAGE OF THE MANUAL .....	13
2.7 - LANGUAGE .....	13
2.8 - APPLIED RATING PLATES .....	14
2.8.1 - GLOSSARY FOR RATING PLATES.....	15
2.9 - GLOSSARY OF MEASUREMENT UNITS.....	16
2.10 - QUALIFIED PROFESSIONAL FIGURES .....	17
<b>3 - SAFETY .....</b>	<b>19</b>
3.1 - GENERAL SAFETY WARNINGS.....	19
3.2 - PERSONAL PROTECTIVE EQUIPMENT.....	20
3.3 - RESIDUAL RISKS .....	21
3.3.1 - TABLE SHOWING RESIDUAL RISKS DUE TO PRESSURE .....	22
3.3.2 - TABLE OF RESIDUAL RISKS FOR POTENTIALLY EXPLOSIVE ATMOSPHERES .....	24
3.4 - OBLIGATIONS AND PROHIBITIONS .....	26
3.5 - SAFETY PICTOGRAMS .....	27
3.6 - NOISE LEVEL .....	27

## 4 - DESCRIPTION AND OPERATION ..... 29

4.1 - GENERAL DESCRIPTION .....	29
4.1.1 - REGULATOR REACTION MODES.....	30
4.2 - OPERATION.....	30
4.3 - INTENDED USE .....	32
4.3.1 - ENVISAGED USE .....	32
4.3.2 - REASONABLY FORESEEABLE MISUSE .....	32
4.3.3 - TYPES OF FLUIDS .....	32
4.4 - TECHNICAL FEATURES/PERFORMANCE .....	33
4.4.1 - VARIATION OF OUTLET PRESSURE AS INLET PRESSURE CHANGES BY 0.5 BAR.....	34
4.4.2 - SPRING SETTING RANGE.....	35
4.4.2.1 - INLET PRESSURE 1.7 BAR.....	35
4.4.2.2 - INLET PRESSURE 3.4 BAR.....	35
4.5 - POSSIBLE CONFIGURATIONS .....	36
4.5.1 - CONTROL HEADS.....	36
4.5.2 - ACCESSORIES.....	36
4.5.3 - REGULATOR WITH MONITOR FUNCTION.....	37
4.5.4 - SLAM-SHUT VALVE .....	40
4.5.4.1 - LA INCORPORATED SLAM-SHUT VALVE.....	41

## 5 - TRANSPORT AND HANDLING ..... 43

5.1 - SPECIFIC WARNINGS FOR TRANSPORT AND HANDLING .....	43
5.1.1 - PACKAGING AND FASTENERS USED FOR TRANSPORT .....	44
5.2 - PHYSICAL CHARACTERISTICS OF THE EQUIPMENT .....	46
5.2.1 - DIVAL 700.....	46
5.2.2 - DIVAL 700 + LA.....	47
5.3 - EQUIPMENT ANCHORING AND LIFTING METHOD.....	48
5.3.1 - FORKLIFT HANDLING METHOD.....	49
5.3.2 - CRANE HANDLING METHOD.....	51
5.4 - PACKAGING REMOVAL.....	52
5.4.1 - PACKAGING DISPOSAL .....	52
5.5 - STORAGE AND ENVIRONMENTAL CONDITIONS .....	53
5.5.1 - PRE-INSTALLATION WARNINGS AFTER PROLONGED STORAGE .....	53

## 6 - INSTALLATION ..... 55

6.1 - INSTALLATION PRE-REQUISITES.....	55
6.1.1 - ALLOWED ENVIRONMENTAL CONDITIONS.....	55
6.1.2 - CHECKS BEFORE INSTALLATION.....	56
6.2 - SPECIFIC SAFETY INSTRUCTIONS FOR THE INSTALLATION STEP .....	57
6.3 - GENERAL INFORMATION ON CONNECTIONS .....	58
6.4 - REGULATOR INSTALLATION POSITIONS.....	59
6.5 - INSTALLATION PROCEDURES .....	60
6.5.1 - EQUIPMENT INSTALLATION PROCEDURES .....	60
6.5.2 - CONNECTION OF THE SENSING LINES TO THE DOWNSTREAM PIPING.....	60
6.6 - POST-INSTALLATION AND PRE-COMMISSIONING CHECKS .....	63

## 7 - COMMISSIONING/MAINTENANCE EQUIPMENT..... 65

7.1 - LIST OF EQUIPMENT.....	65
7.2 - EQUIPMENT NEEDED FOR THE DIFFERENT CONFIGURATIONS.....	67

## 8 - COMMISSIONING ..... 69

8.1 - GENERAL WARNINGS .....	69
8.1.1 - SAFETY REQUIREMENTS FOR COMMISSIONING .....	69
8.2 - PRELIMINARY PROCEDURES FOR COMMISSIONING .....	70
8.3 - PROPER COMMISSIONING CHECK .....	71
8.4 - CALIBRATION OF EQUIPMENT AND ACCESSORIES INSTALLED.....	71
8.5 - REGULATOR COMMISSIONING PROCEDURE .....	72
8.6 - COMMISSIONING PROCEDURE OF REGULATION LINE: DIVAL 700 REGULATOR + DIVAL 700 REGULATOR WITH IN LINE MONITOR FUNCTION .....	74
8.6.1 - PRESSURISING WITH EXTERNAL SOURCE.....	78
8.7 - COMMISSIONING PROCEDURE OF DIVAL 700 REGULATOR WITH LA SLAM-SHUT VALVE.....	80
8.7.1 - INTERNAL TIGHTNESS CHECK OF LA SLAM-SHUT VALVE.....	80
8.7.2 - COMMISSIONING OF THE DIVAL 700 REGULATOR WITH LA SLAM-SHUT VALVE.....	81
8.7.3 - PROCEDURE FOR CALIBRATING THE PRESSURE SWITCH FOR THE LA INCORPORATED SLAM-SHUT VALVE.....	84
8.8 - COMMISSIONING PROCEDURE OF REGULATION LINE: DIVAL 700 REGULATOR + DIVAL 700 REGULATOR WITH IN LINE MONITOR + LA SLAM-SHUT VALVE FUNCTION .....	88
8.9 - DEVICE CALIBRATION.....	92
8.9.1 - PRESSURE SWITCH CALIBRATION FOR THE LA SLAM-SHUT VALVE .....	92



## **9 - MAINTENANCE AND FUNCTIONAL CHECKS..... 93**

9.1 - GENERAL WARNINGS .....	93
9.2 - PERIODICALLY CHECKING AND INSPECTING THE EQUIPMENT FOR PROPER OPERATION.....	95
9.3 - ROUTINE MAINTENANCE .....	96
9.3.1 - GENERAL SAFETY WARNINGS.....	96
9.3.2 - REPLACEMENT FREQUENCY FOR COMPONENTS SUBJECT TO WEAR .....	97
9.4 - ROUTINE MAINTENANCE PROCEDURES.....	99
9.4.1 - TIGHTENING TORQUES .....	100
9.4.2 - REPLACING ELEMENTS SUBJECT TO WEAR AND ABRASION.....	107
9.4.3 - REGULATOR MAINTENANCE PROCEDURE DIVAL 700.....	108
9.4.4 - LA SLAM-SHUT VALVE .....	120
9.4.6 - PROCEDURE FOR RECOMMISSIONING AFTER MAINTENANCE .....	132

## **10 - TROUBLESHOOTING..... 133**

10.1 -GENERAL WARNINGS .....	133
10.2 -OPERATOR QUALIFICATION SPECIFICATION.....	134
10.3 -TROUBLESHOOTING PROCEDURES .....	134
10.4 -TROUBLESHOOTING TABLES .....	135
10.4.1 -TROUBLESHOOTING DIVAL 700 REGULATOR.....	135
10.4.2 -LA SLAM-SHUT VALVE TROUBLESHOOTING.....	135

## **11 - UNINSTALLATION AND DISPOSAL ..... 137**

11.1 -GENERAL SAFETY WARNINGS.....	137
11.2 -QUALIFICATION OF THE OPERATORS IN CHARGE.....	137
11.3 -UNINSTALLATION.....	137
11.4 -INFORMATION REQUIRED IN CASE OF RE-INSTALLATION.....	137
11.5 -DISPOSAL INFORMATION.....	138

## **12 - RECOMMENDED SPARE PARTS ..... 139**

12.1 -GENERAL WARNINGS .....	139
12.2 -HOW TO REQUEST SPARE PARTS.....	139

## **13 - FLOW RATE TABLES..... 141**

13.1 -FLOW RATE TABLES .....	141
------------------------------	-----



## 2 - GENERAL INFORMATION

### 2.1 - MANUFACTURER IDENTIFICATION

<b>Manufacturer</b>	PIETRO FIORENTINI S.P.A.
<b>Address</b>	Via Enrico Fermi, 8/10 36057 Arcugnano (VI) - ITALY <b>Tel. +39 0444 968511 Fax +39 0444 960468</b> <b>www.fiorentini.com sales@fiorentini.com</b>

Tab. 2.2

### 2.2 - IDENTIFICATION OF THE PRODUCT

<b>Equipment</b>	REGOLATORE PER MEDIA PRESSIONE
<b>Model</b>	DIVAL 700

Tab. 2.3

### 2.3 - REGULATORY FRAMEWORK

PIETRO FIORENTINI S.P.A., with registered offices in Arcugnano (Italy) - Via E. Fermi, 8/10, declares under its sole responsibility that the equipment of the DIVAL 700 series described in this manual is designed, manufactured, tested and checked in compliance with the requirements of EN 334 standard on gas pressure regulators.

The equipment complies with the requirements of Directive 2014/68/EU ("Pressure Equipment Directive" PED). The assessment procedure adopted is in accordance with module H1 as per Annex III of the Directive.

#### **NOTICE!**

**The declaration of conformity in its original version is delivered together with the equipment and this operating and warning manual.**

### 2.4 - WARRANTY

PIETRO FIORENTINI S.P.A. guarantees that the equipment was manufactured using the best materials, with high quality workmanship, and complies with the quality requirements, specifications and performance set out in the order.



The warranty shall be considered null and void and PIETRO FIORENTINI S.P.A. shall not be liable for any damage and/or malfunctions:

- due to any acts or omissions of the purchaser or end-user, or any of their carriers, employees, agents, or any third party or entity;
- in the event that the purchaser, or a third party, makes changes to the equipment supplied by PIETRO FIORENTINI S.P.A. without the prior written approval of the latter;
- in the event of failure by the purchaser to comply with the instructions contained in this manual, as provided by PIETRO FIORENTINI S.P.A.

#### **NOTICE!**

**The warranty conditions are specified in the commercial contract.**

## 2.5 - SYMBOLS USED IN THE MANUAL

Symbol	Definition
	Symbol used to identify important warnings for the safety of the operator and/or equipment.
	Symbol used to identify information of particular importance in the instruction manual. The information may also concern the safety of the personnel involved in using the equipment.
	Obligation to consult the instruction manual/booklet. Indicates a requirement for the personnel to refer to (and understand) the operating and warning instructions of the machine before working with or on it.

Tab. 2.4

### HAZARD!

Alerts to a hazard with a high level of risk, an imminent hazardous situation which, if not prevented, will result in death or severe damage.

### WARNING!

Alerts to a hazard with a medium level of risk, a potentially hazardous situation which, if not prevented, may result in death or severe damage.

### ATTENTION!

Alerts to a hazard with a low level of risk, a potentially hazardous situation which, if not prevented, could result in minor or moderate damage.

### NOTICE!

Alerts to specific warnings, directions or notes of particular concern, that are not related to physical injury, as well as practices for which physical injury is not likely to occur.

## 2.6 - ADDRESSEES, SUPPLY AND STORAGE OF THE MANUAL

The instruction manual is intended for qualified technicians responsible for operating and managing the equipment throughout its service life.

It contains the necessary information to properly use the equipment and keep its functional and qualitative characteristics unchanged over time. All information and warnings for safe, correct use are also provided.

The instruction manual, as well as the declaration of conformity and/or test certificate, is an integral part of the equipment and must always accompany it whenever it is moved or resold. It is up to the user to keep this documentation intact for reference throughout the lifespan of the equipment.

### **WARNING!**

**Removing, rewriting or editing the pages of the manual and their contents is not allowed.**

**Keep the instruction manual near the equipment, in an accessible place known by all qualified technicians involved in using and running it.**

**PIETRO FIORENTINI S.p.A. shall not be held liable for any damage to people, animals and property caused by failure to adhere to the warnings and operating procedures described in this manual.**

## 2.7 - LANGUAGE

The original instruction manual was drawn up in Italian.

Any translations into additional languages are to be made from the original instruction manual.

### **HAZARD!**

**The Manufacturer is not responsible for any incomplete translations. If any inconsistency is found, please refer to the text of the original manual.**

**If inconsistencies are found or the text does not make sense:**

- stop any actions;
- immediately contact the relevant offices of PIETRO FIORENTINI S.p.A.

### **WARNING!**

**PIETRO FIORENTINI S.p.A. shall be held liable for the information provided in the original manual only.**

## 2.8 - APPLIED RATING PLATES

### WARNING!

**Removing nameplates and/or replacing them with other plates is strictly not allowed.  
Should the plates be unintentionally damaged or removed, the customer must notify  
PIETRO FIORENTINI S.p.A.**

The equipment and its accessories are provided with nameplates (from Id.1 to Id.2).

The rating plates specify identification details of the equipment and its accessories to be provided, if necessary, to PIETRO FIORENTINI S.p.A.

“Tab. 2.5” shows the nameplates applied:

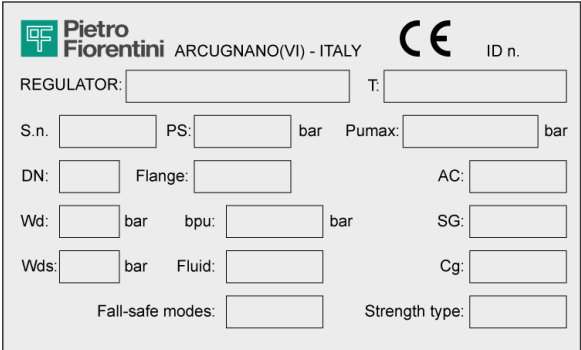
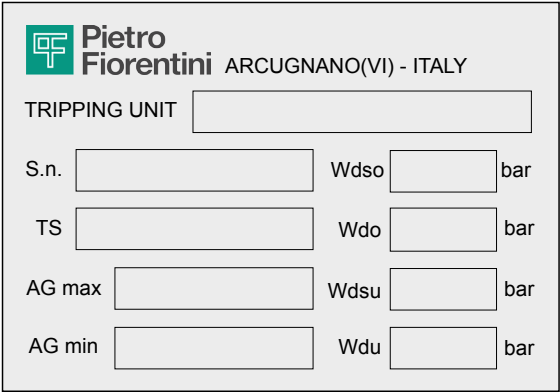
Id.	Type	Image
1	NAMEPLATE REGULATOR (EC version) AND REGULATOR WITH IN LINE MONITOR FUNCTION	
2	NAMEPLATE SLAM-SHUT VALVE	

Tab. 2.5

## 2.8.1 - GLOSSARY FOR RATING PLATES

The terms and abbreviations used on nameplates are described in "Tab. 2.6":

Term	Description
<b>AC</b>	Accuracy class.
<b>AG max</b>	Slam-shut valve accuracy class due to pressure increase. "OPSO" (Over pressure shut off).
<b>AG min</b>	Slam-shut valve accuracy class due to pressure decrease. "UPSO"(Under pressure shut off).
<b>bpu</b>	Range of inlet pressure for which the regulator ensures a given accuracy class.
<b>CE</b>	Marking certifying compliance with applicable European directives.
<b>Cg</b>	Flow rate coefficient.
<b>Class</b>	Alphanumeric designation used for reference purposes related to a combination of mechanical and dimensional characteristics for flanges, in accordance with the relevant parts of EN 1759 series, which includes the word Class followed by a dimensionless whole number.
<b>DN</b>	Nominal size of connections.
<b>Fail safe mode</b>	Regulator reaction mode (Fail open or Fail close).
<b>Flange</b>	Type of flanged connections or type of connection thread.
<b>Fluid</b>	Type of fluid compatible with the equipment.
<b>ID no.</b>	Number of the Notified Body participating in the conformity assessment of the equipment.
<b>Pilot</b>	Pilot family.
<b>PS</b>	Maximum permissible pressure for which the equipment was designed.
<b>Pumax</b>	Maximum inlet pressure at which the regulator can operate continuously under specific conditions.
<b>REGULATOR</b>	Equipment family.
<b>SG</b>	Shut-off pressure class.
<b>Slam-shut device</b>	Slam-shut valve family.
<b>S.n.</b>	Equipment serial number.
<b>Strength type</b>	Strength class: Integral strength or differential strength (DS).
<b>T</b>	Permissible temperature range (min. and max.) for which the equipment was designed.
<b>Tripping unit</b>	Pressure switch family.
<b>Type</b>	Accessory type and family.
<b>Wd</b>	Full setpoint range that can be obtained from the regulator by adjusting and/or replacing certain components (e.g. replacement of valve seat or control element, e.g. spring).
<b>Wdo</b>	Full setpoint range with regard to tripping caused by increased pressure in the pressure switch incorporated in the slam-shut valve. This range can be obtained by adjusting and/or replacing the components (for example, spring or sensitive element).
<b>Wds</b>	Full setpoint range that can be obtained from the regulator by adjusting but not replacing the components.
<b>Wdso</b>	Full setpoint range with regard to tripping caused by increased pressure in the pressure switch incorporated in the slam-shut valve. This range can be obtained by adjusting but not replacing the components.
<b>Wdu</b>	Full setpoint range with regard to tripping caused by decreased pressure in the pressure switch incorporated in the slam-shut valve. This range can be obtained by adjusting and/or replacing the components (for example, spring or sensitive element).

Term	Description
<b>Wdsu</b>	Full setpoint range with regard to tripping caused by decreased pressure in the pressure switch incorporated in the slam-shut valve. This range can be obtained by adjusting but not replacing the components.

Tab. 2.6

## 2.9 - GLOSSARY OF MEASUREMENT UNITS

Type of measurement	Unit of measurement	Description
<b>Volumetric flow rate</b>	Sm <sup>3</sup> /h	Standard cubic metres per hour
	Scfh	Standard cubic feet per hour
<b>Pressure</b>	bar	Unit of measurement in the CGS system
	psi	Pounds per square inch
	"wc	Water column inch
	Pa	Pascal
<b>Temperature</b>	°C	Degree centigrade
	°F	Fahrenheit degree
	K	Kelvin
<b>Tightening torque</b>	Nm	Newton metre
	ft-lbs	Foot per pound
<b>Sound pressure</b>	dB	Decibel
<b>Other measures</b>	V	Volt
	W	Watt
	Ω	Ohm

Tab. 2.7



## 2.10 - QUALIFIED PROFESSIONAL FIGURES

Qualified operators in charge of using and managing the equipment throughout its technical service life:

Professional figure	Definition
<b>Mechanical maintenance technician</b>	<p>Qualified technician able to:</p> <ul style="list-style-type: none"> <li>perform preventive/corrective maintenance operations on all mechanical parts of the equipment subject to maintenance or repair;</li> <li>access all device parts for visual inspection, equipment checks, adjustments and calibrations.</li> </ul> <p>The maintenance mechanical technician is not authorised to operate on live electrical systems (if any).</p>
<b>Electrical maintenance technician</b>	<p>Qualified technician able to:</p> <ul style="list-style-type: none"> <li>perform preventive/corrective maintenance operations on all electrical parts of the device subject to maintenance or repair;</li> <li>read wiring diagrams and check the correct functional cycle;</li> <li>perform adjustments and operate on electrical systems for maintenance, repair and replacement of worn parts.</li> </ul> <p>The electrical maintenance technician can operate in the presence of voltage inside electrical panels, junction boxes, control equipment etc. only if he/she is deemed to be suitable (S.P.).</p> <p>For general requirements, refer to the IEC EN 50110-1:2014 standard.</p>
<b>Worker in charge of transport, handling, unloading and placement on site</b>	<p>Operator qualified to:</p> <ul style="list-style-type: none"> <li>use lifting equipment;</li> <li>handle materials and equipment.</li> </ul> <p>The equipment must be lifted and handled strictly in accordance with the instructions provided by the manufacturer as well as the regulations in force at the place where the equipment is installed.</p>
<b>Installer</b>	<p>Qualified operator able to:</p> <ul style="list-style-type: none"> <li>carry out all the operations necessary to properly install the equipment;</li> <li>perform all the operations necessary for the proper functioning of the equipment and the system in safety.</li> </ul>
<b>User's technician</b>	<p>Technician trained and authorized to use and manage the equipment for the activities for which it was supplied. They must:</p> <ul style="list-style-type: none"> <li>be able to perform all operations required to properly run the equipment and the system, ensuring their own safety and that of any personnel on site;</li> <li>have proven experience in properly using the equipment similar to that described in this manual, and be trained, informed and instructed in this regard.</li> </ul> <p>The technician may carry out maintenance only if authorised/qualified to do so.</p>

Tab. 2.8



## 3 - SAFETY

### 3.1 - GENERAL SAFETY WARNINGS

#### WARNING!

The equipment described in this instruction manual is:

- a device subjected to pressure in pressurised systems;
- normally installed in systems carrying flammable gases (for example: natural gas).

#### WARNING!

If the gas used is a combustible gas, the installation area of the equipment is defined as a “danger zone” as there are residual risks that potentially explosive atmospheres may be generated.

In “danger zones” and in close proximity thereto:

- there must not be any effective sources of ignition;
- no smoking.

#### ATTENTION!

Authorised operators must not carry out operations or services on their own initiative that do not fall within their competence.

Never operate the equipment:

- while under the influence of intoxicating substances such as alcohol;
- if you are using drugs that may lengthen reaction times.

#### NOTICE!

The employer must train and inform operators on how to behave during operations and on the equipment to be used.

Before installation, commissioning or maintenance, operators must:









- take note of the safety regulations applicable to the place of installation they are working in;
- obtain the necessary permits to operate when required;
- wear the personal protective equipment required by the procedures described in this instruction manual;
- ensure that the required collective protective equipment and safety information are available in the area they are operating in.

### 3.2 - PERSONAL PROTECTIVE EQUIPMENT

"Tab. 3.9" shows the personal protective equipment (PPE) and its description. An obligation is associated with each symbol.

Personal protective equipment means any equipment intended to be worn by the worker in order to protect them against one or several risks that are likely to threaten their safety or health during work.

For the operators in charge, depending on the type of work requested, the most appropriate PPE of the following will be reported and must be used:

Symbol	Meaning
	<b>Obligation to use safety or insulated gloves.</b> Indicates a requirement for the personnel to use safety or insulated gloves.
	<b>Obligation to use safety goggles.</b> Indicates a requirement for personnel to use protective goggles for eye protection.
	<b>Obligation to use safety shoes.</b> Indicates a requirement for the personnel to use accident-prevention safety shoes.
	<b>Obligation to use noise protection equipment.</b> Indicates a requirement for the personnel to use ear muffs or ear plugs to protect their hearing.
	<b>Obligation to wear protective clothing.</b> Indicates a requirement for the personnel to wear specific protective clothing.
	<b>Obligation to use a protective mask.</b> Indicates a requirement for the personnel to use respiratory masks in the event of a chemical risk.
	<b>Obligation to use a protective helmet.</b> Indicates a requirement for the personnel to use protective helmets.
	<b>Obligation to wear high visibility vests.</b> Indicates a requirement for the personnel to use high visibility vests.

Tab. 3.9

#### **WARNING!**

Each licensed operator is obliged to:

- **take care of his/her own health and safety and that of other people in the workplace who are affected by his/her actions or omissions, in accordance with the training, instructions and equipment provided by the employer;**
- **appropriately use the PPE made available;**
- **immediately report to the employer, the manager or the person in charge any deficiencies in the equipment and devices, as well as any dangerous conditions they may become aware of.**

### **3.3 - RESIDUAL RISKS**

In accordance with the requirements of PED 2014/68/EU, point 1.2 of Annex I, below is an assessment of the risks associated with the equipment and an indication of the principles adopted for their prevention, according to the following classification:

- a) Elimination and/or reduction of the risk.
- b) Application of appropriate protective measures.
- c) Information to users about residual risks.

### 3.3.1 - TABLE SHOWING RESIDUAL RISKS DUE TO PRESSURE

Risk and hazard	Event and Cause	Effect and consequence	Solution and prevention
<b>Pressurised gas leak. Projection of metallic and non-pressurised parts.</b>	<ul style="list-style-type: none"> <li>Violent impact;</li> <li>Impact (also due to falling, improper handling, etc.).</li> </ul>	<ul style="list-style-type: none"> <li>Deformation;</li> <li>Broken connections and, if pressurised, even burst.</li> </ul>	<p>a. Handling and installation with appropriate devices to avoid localised stress.</p> <p>b. Installation in suitable places and spaces with appropriate guards and packaging.</p> <p>c. Information in the instructions for use and warning.</p>
<b>Pressurised gas leak. Projection of metallic and non-pressurised parts.</b>	<ul style="list-style-type: none"> <li>Use of inappropriate fluids.</li> </ul>	<ul style="list-style-type: none"> <li>Corrosion;</li> <li>Embrittlement;</li> <li>Explosion.</li> </ul>	<p>a. The user must check compliance of the used fluid with the specifications on the data plate.</p>
<b>Pressurised gas leak. Projection of metallic and non-pressurised parts.</b>	<ul style="list-style-type: none"> <li>Operation at temperatures below the minimum permissible temperature.</li> </ul>	<ul style="list-style-type: none"> <li>Embrittlement;</li> <li>Breakage;</li> <li>Explosion.</li> </ul>	<p>a. Install in places where the temperature is not below the minimum permissible temperature and/or insulate the equipment adequately.</p> <p>b. The minimum temperature allowed is indicated on the data plate.</p>
<b>Pressurised gas leak. Projection of metallic and non-pressurised parts. Explosion.</b>	<ul style="list-style-type: none"> <li>Overpressure or exceedance of the rated limit values (maximum pressure allowed)</li> </ul>	<ul style="list-style-type: none"> <li>Explosion;</li> <li>Breaks;</li> <li>Cracks;</li> <li>Permanent deformations.</li> </ul>	<p>a. The device has appropriate design safety margins.</p> <p>b. The user must check the maximum pressure applicable to the equipment.</p> <p>c. The maximum allowable pressure is highlighted on the appropriate plate on the equipment.</p>
<b>Falling of the equipment.</b>	<ul style="list-style-type: none"> <li>Dangerous handling.</li> </ul>	<ul style="list-style-type: none"> <li>Deformation;</li> <li>Cracking;</li> <li>Breakage.</li> </ul>	<p>b. The user must have suitably sized lifting equipment.</p> <p>c. The above requirements are referred to in the equipment use and warning manual.</p>
<b>Pressurised fluid leakage. Projection of metallic and non-pressurised parts.</b>	<ul style="list-style-type: none"> <li>Incorrect fixing of the equipment.</li> </ul>	<ul style="list-style-type: none"> <li>Deformation;</li> <li>Breakage.</li> </ul>	<p>a. The device is equipped with unified type process connections and compression fittings.</p> <p>b. The user must ensure correct fixing to the line.</p> <p>c. Directions in the instructions for use and warning.</p>
<b>Explosion of the device. Pressurised fluid leakage. Projection of metallic parts.</b>	<ul style="list-style-type: none"> <li>Operation at temperatures above the maximum permissible temperature.</li> </ul>	<ul style="list-style-type: none"> <li>Reduction of mechanical resistance and breakage of the device;</li> <li>Explosion.</li> </ul>	<p>a. The user must equip the system with suitable safety and control devices.</p> <p>b. The maximum temperature allowed is indicated on the data plate.</p>
<b>Pressurised gas leak.</b>	<ul style="list-style-type: none"> <li>Device maintenance with the system running.</li> </ul>	<ul style="list-style-type: none"> <li>Inappropriate opening of pressurised chambers.</li> </ul>	<p>a. The user must perform any maintenance with the equipment not in operation.</p> <p>b. The above requirements are referred to in the use and warning manual.</p>

Risk and hazard	Event and Cause	Effect and consequence	Solution and prevention
<b>Pressurised gas leak. Projection of metallic and non-pressurised parts.</b>	<ul style="list-style-type: none"> <li>External loads bearing on the device.</li> </ul>	<ul style="list-style-type: none"> <li>Deformation;</li> <li>Cracking and slot formation;</li> <li>If under pressure, burst also.</li> </ul>	a. With the exclusion of what is set out in the project, the user must verify that no additional concentrated load bears on the device.
<b>Pressurised gas leak. Projection of metallic and non-pressurised parts.</b>	<ul style="list-style-type: none"> <li>Electrostatic potential, differential stray currents.</li> </ul>	<ul style="list-style-type: none"> <li>Corrosion localised in the device.</li> </ul>	b. The user must equip the device with the necessary protection and earthing devices. c. The above requirements are referred to in the use and warning manual.
<b>Pressurised gas leak. Projection of metallic and non-pressurised parts.</b>	<ul style="list-style-type: none"> <li>Humidity;</li> <li>Environments with aggressive atmosphere.</li> </ul>	<ul style="list-style-type: none"> <li>Deterioration of external surfaces;</li> <li>Corrosion.</li> </ul>	a. The user must periodically check the state of conservation of the external surfaces. b. The above requirements are referred to in the use and warning manual.

Tab. 3.10

### 3.3.2 - TABLE OF RESIDUAL RISKS FOR POTENTIALLY EXPLOSIVE ATMOSPHERES

“Tab. 3.11” shows the conditions that can lead to the generation of a potentially explosive atmosphere respectively for:

- DIVAL 700 pressure regulator;
- the LA slam-shut valve.

Considering that the silencer does not have active functional parts, in this analysis it is considered an integral part of the DIVAL 700 regulator.

The table is valid for use with natural gas with a density of no more than 0.8; for different densities, the installation and environmental conditions must also be evaluated.

#### **WARNING!**

**If the gas used is a combustible gas, the installation area of the equipment is defined as a “danger zone” as there are residual risks that potentially explosive atmospheres may be generated.**

**There must be no effective sources of ignition in “danger zones” and in close proximity thereto.**

Operating conditions	Potentially explosive atmosphere	Normative references	Management measures included in the instructions for use and warning
<b>First start-up</b>	No	<ul style="list-style-type: none"> <li>• During the production cycle and before the CE marking according to Directive 2014/68/EU, the external tightness of the equipment is checked at a value of 1.1 PS (in accordance with Standard EN 334).</li> <li>• Before commissioning, the external sealing of the system portion on which the equipment is installed is checked at a suitable pressure (in accordance with the provisions of standards EN 12186 and EN 12279).</li> </ul>	The instructions for use indicate the need to meet the requirements in Standards EN 12186 and EN 12279.
<b>Operation in normal conditions</b>	No	<p>The indications in the previous point apply, in addition:</p> <ul style="list-style-type: none"> <li>• the equipment is installed outdoors or in an environment with natural ventilation (in accordance with Standards EN 12186 and EN 12279);</li> <li>• the installation is subject to surveillance according to current national rules/good practice/the equipment manufacturer's instructions (in accordance with the provisions of Standard EN 12186 and Standard EN 12279).</li> </ul>	<p>The instructions for use indicate that:</p> <ul style="list-style-type: none"> <li>• any environment in which the equipment is installed must meet the requirement of Standards EN 12186 and EN 12279;</li> <li>• periodic checks and maintenance must be carried out during surveillance in accordance with the national rules in force (if any), and with the specific manufacturer's recommendations.</li> </ul>
<b>Breakage of the control head diaphragm (malfunction)</b>	No	<p>This event must be considered a rare malfunction.</p> <p>All atmospheric pressure chambers delimited on at least one side by a diaphragm must be channelled to a safe area (in accordance with the provisions of Standard EN 12186 and Standard EN 12279).</p>	The instructions for use indicate the need to meet the requirements of Standards EN 12186 and EN 12279.



Operating conditions	Potentially explosive atmosphere	Normative references	Management measures included in the instructions for use and warning
<b>Breakage of other non-metallic parts (malfunction)</b>	No	This type of malfunction is not reasonably expected as it involves static sealing (to the outside).	-
<b>Decommissioning</b>	No	<ul style="list-style-type: none"> <li>The pressure of the system section in which the equipment is installed must be reduced with appropriate vent lines channelled to a safe area (in accordance with the provisions of Standard EN 12186 and Standard EN 12279).</li> <li>The residual gas must be discharged as indicated above.</li> </ul>	The instructions for use indicate the need to meet the requirements of Standards EN 12186 and EN 12279
<b>Reboot</b>	No	<ul style="list-style-type: none"> <li>After reassembling the regulator, carry out an external leakage test at a convenient pressure value as specified by the manufacturer.</li> <li>Before commissioning, the external sealing of the system portion on which the equipment is installed is checked at a suitable pressure (in accordance with the provisions of standards EN 12186 and EN 12279).</li> </ul>	The instructions for use indicate: <ul style="list-style-type: none"> <li>the minimum conditions for testing internal leakage;</li> <li>the need to meet the requirements of Standards EN 12186 and EN 12279.</li> </ul>

Tab. 3.11

### 3.4 - OBLIGATIONS AND PROHIBITIONS

The following is a list of obligations and prohibitions to be observed for the safety of the operator.

It is mandatory to:



- carefully read and understand the instructions for use and warning;
- check whether the downstream equipment is suitably sized according to the performance required of the regulator in the actual operating condition;
- before installing the equipment, the data on the nameplates must be checked;
- Avoid violent shocks and impacts that could damage the equipment and, as a result, cause the pressure fluid to escape.

It is forbidden to:

- operate in various capacities on the equipment without the PPE indicated in the work procedures described in these use and warning instructions;
- operate in the presence of open flames or bring open flames close to the work area;
- smoke near the equipment or while working on it;
- use the equipment with parameters other than those indicated on the nameplate;
- use the equipment with fluids other than those indicated on the nameplate and in these use and warning instructions;
- use the equipment outside the operating temperature range specified on the nameplate and in these use and warning instructions;
- service the equipment with the system portion, on which it is installed, running;
- install or use the equipment in environments other than those specified in these instructions for use and warning.

### 3.5 - SAFETY PICTOGRAMS

The following safety pictograms may be shown on the equipment and/or packaging PIETRO FIORENTINI S.p.A.:

Symbol	Meaning
	Symbol used to identify an ELECTRICAL HAZARD.
	Symbol used to identify a GENERIC HAZARD.

Tab. 3.12

#### HAZARD!

**It is absolutely forbidden to remove the safety pictograms on the equipment.**

**The user is required to replace the safety pictograms which, following wear, removal or tampering, are illegible.**

### 3.6 - NOISE LEVEL

Depending on the operating conditions, use and configuration required, the equipment may generate noise beyond the limits allowed by current legislation in the country of installation.

For the value of the noise generated by the equipment and further information, contact PIETRO FIORENTINI S.p.A.

#### ATTENTION!

**The obligation to use earmuffs or ear plugs to protect the operator's hearing remains in the event that the noise in the installation environment of the equipment (depending on specific operating conditions) exceeds the value of 85 dBA.**



## 4 - DESCRIPTION AND OPERATION

### 4.1 - GENERAL DESCRIPTION

DIVAL 700 is a direct acting pressure regulator for medium and low pressure that reduces the inlet gas pressure while maintaining a stable downstream value even when the required flow rate varies within the operating conditions of the equipment.

The main elements of the equipment are (see Fig. 4.1):

Pos.	Description	Pos.	Description
1	Regulator body	6	Lever mechanism
2	Valve seat	7	Setting spring
3	Plug	8	Relief spring
4	Rod	9	Limit switches
5	Main diaphragm		

Tab. 4.13

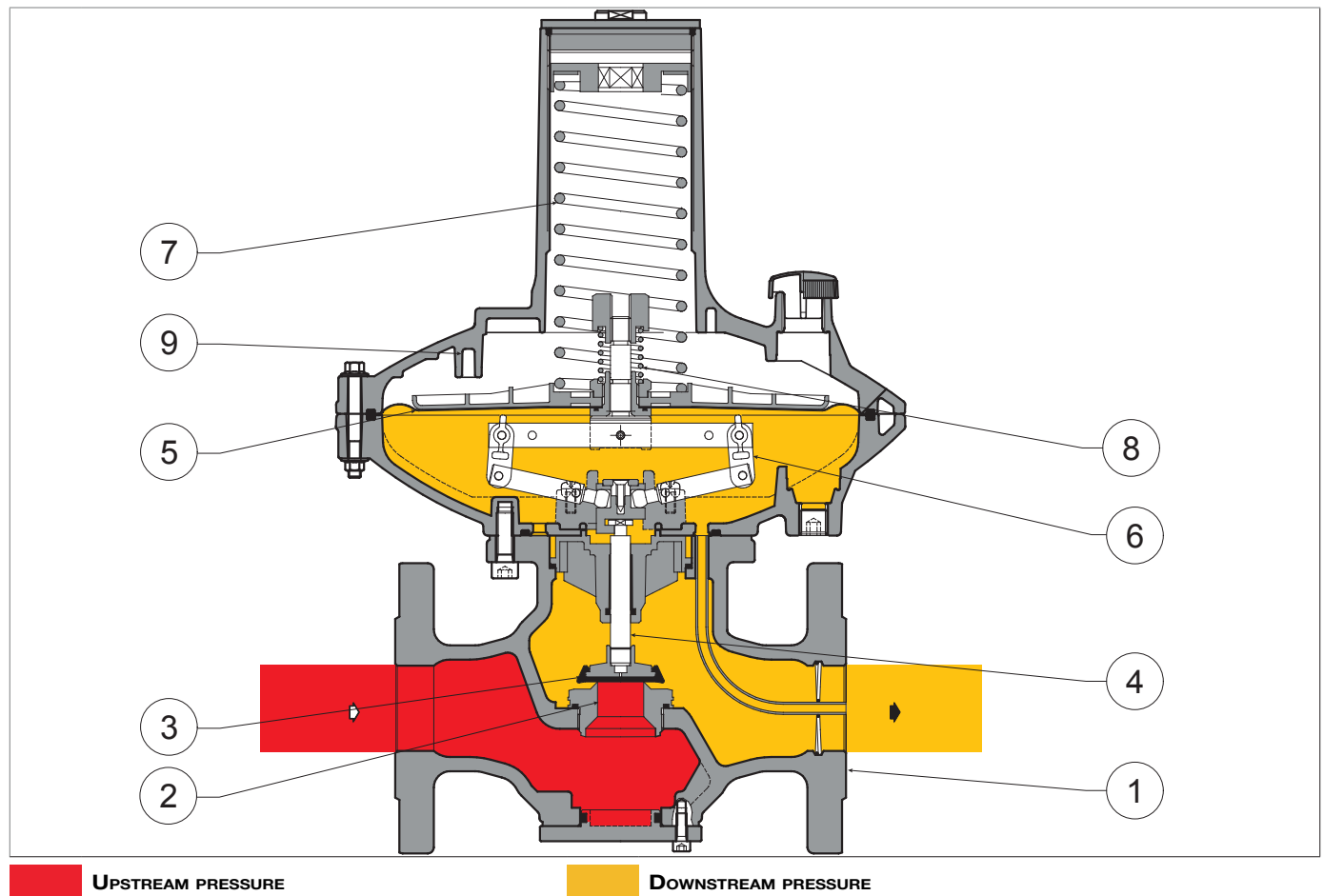

Fig. 4.1. General description DIVAL 700

#### 4.1.1 - REGULATOR REACTION MODES

The DIVAL 700 equipment is a direct acting regulator with a “fail open” reaction (on-opening reaction), that is, it opens in the event of:

- breakage of main diaphragm
- downstream pressure signal missing.

#### 4.2 - OPERATION

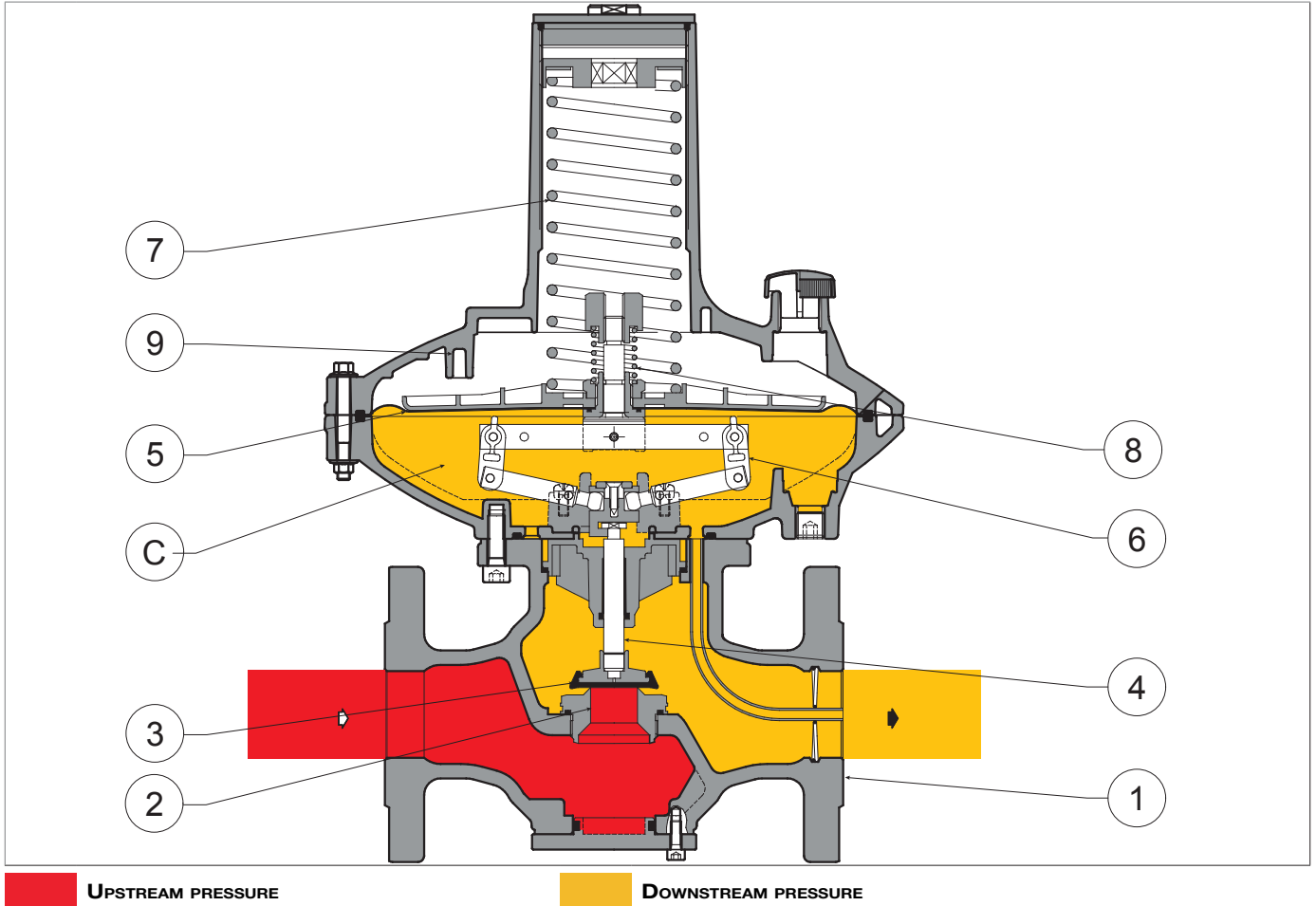

Fig. 4.2. Operation DIVAL 700

In the absence of pressure, the plug (3) is held in the open position by the spring thrust acting on the plug (3) through the engagement of the rod (4) by the lever mechanism (6).

The downstream pressure value (Pd) is regulated by comparing:

- the load of the setting spring (7)
- the thrust that the downstream pressure (Pd) itself exerts on the main diaphragm (5)
- the thrust resulting from the upstream pressure (Pu) on the plug (3).

The main diaphragm (5) moves the rod (4) and the plug (3). The rod (4) moves perpendicularly with respect to the gas flow. In the case of zero flow, the plug (3) closes on the seat and allows the downstream pressure not to rise above the closing pressure value.

Under normal work conditions, the plug (3) positions itself so as to keep the pressure downstream (Pd) around the pre-established calibration value.

The position of the plug (3) is controlled by the movements of the main diaphragm (5). The forces which affect the position of the plug (3) are:

- towards the closed position: the thrust resulting from the downstream pressure (Pd) in the chamber (C)
- towards the open position: the load of the setting spring (7).

Variations in the upstream pressure (Pu) change the value of the downstream pressure (Pd) in relation to the cross-section of the mounted valve seat and the setting spring.

The limit switch (9) positioned in the regulator head eliminates the effects of possible overpressure below the main diaphragm (5) or overloading of the setting spring (7), such as damage to the main diaphragm (5) or excessive load on the plug.

If, during operation, the following should occur:

Operating conditions	Operating consequences	Concluding outcome
<p><b>Decrease in downstream pressure (Pd) for:</b></p> <ul style="list-style-type: none"> <li>• <b>increase in the requested flow rate;</b></li> <li>• <b>drop in pressure upstream (Pu).</b></li> </ul>	<p>The thrust on the main diaphragm (5) is less than the load on the setting spring (7) and moves the plug (3) towards the open position.</p>	<p>Increase in flow until the preset value of the downstream pressure (Pd) is restored.</p>
<p><b>Increased downstream pressure (Pd) due to:</b></p> <ul style="list-style-type: none"> <li>• <b>drop in the requested flow rate;</b></li> <li>• <b>increase in pressure upstream (Pu).</b></li> </ul>	<p>The thrust on the main diaphragm (5) is greater than the load on the setting spring (7) and moves the plug (3) towards the closed position.</p>	<p>Decrease in flow rate until the preset value of downstream pressure (Pd) is restored.</p>

Tab. 4.14

## 4.3 - INTENDED USE

### 4.3.1 - ENVISAGED USE

The equipment in question is intended for:

Operation	Permitted	Not permitted	Work environment
<b>Adjustment of the downstream pressure for:</b>	Gaseous, and non-corrosive, fluids that have been filtered beforehand.	<ul style="list-style-type: none"> <li>Liquids.</li> <li>Any product other than those permitted.</li> </ul>	Installations for the transport and distribution of gas fuel to supply networks for: <ul style="list-style-type: none"> <li>civil use;</li> <li>industrial use.</li> </ul>

Tab. 4.15

The equipment in question is used as a main regulator and in-line monitor regulator.

It was designed to be used exclusively within the limits specified on the nameplate and according to the instructions and limits of use referred to in this manual.

Safe work conditions are as follows:

- use within the limits stated on the nameplate and in this manual;
- compliance with the user manual procedures;
- routine maintenance to be carried out when and how recommended;
- special maintenance to be carried out if required;
- do not tamper with and/or bypass the safety devices.

### 4.3.2 - REASONABLY FORESEEABLE MISUSE

Reasonably foreseeable misuse means the use of the equipment in a way not foreseen in the phase but which can result from readily foreseeable human behaviour:

- corrosive fluids;
- fluids not properly treated upstream;
- liquids;
- instinctive reaction of an operator in the event of a malfunction, accident or breakdown while using the equipment;
- behaviour resulting from pressure to keep the equipment running under all circumstances;
- behaviour resulting from carelessness;
- behaviour resulting from the use of the equipment by unauthorised and unsuitable people;
- using the equipment in a manner other than that referred to under “4.3.1 - Envisaged use”.

Any use of the equipment other than the intended use must be previously approved in writing by PIETRO FIORENTINI S.p.A. If no written approval is provided, use shall be considered improper.

In the event of “improper use”, PIETRO FIORENTINI S.p.A. shall not be held liable for any damage caused to people or property, and any type of warranty on the equipment shall be deemed void.

### 4.3.3 - TYPES OF FLUIDS

The equipment works with combustible gases used:

- in pressure control stations according to EN 12186 or EN 12279;
- in transmission and distribution networks.
- in commercial and industrial plants (after checking by contacting the Manufacturer).

#### NOTICE!

**The equipment may be also used with inert gases, subject to verification by contacting the manufacturer.**



#### 4.4 - TECHNICAL FEATURES/PERFORMANCE

The DIVAL 700 equipment is a regulator for medium and low pressure. The regulation system is unbalanced with an outlet pressure that varies with the inlet pressure.

The main specifications for this regulator are:

Technical features	
Maximum allowable pressure	Up to 20 bar
Ambient temperature range	-20 °C - +60 °C
Inlet gas temperature range	-20 °C - +60 °C
Inlet pressure range (bpu)	Depending on the valve seat installed: <ul style="list-style-type: none"> <li>• 1/4": 8,63 bar</li> <li>• 3/8": 8,63 bar</li> <li>• 1/2": 8,63 bar</li> <li>• 3/4": 5 bar</li> <li>• 1": 3,45 bar</li> <li>• 1" 1/4: 2,07 bar</li> </ul>
Possible regulation range (Wd)	0,005 - 1,45 bar
Minimum differential pressure	0.1 bar
Accuracy class (AC)	up to 5 (depending on operating conditions)
Lock up pressure class (SG)	up to 5 (depending on operating conditions)
Connections	<ul style="list-style-type: none"> <li>• Flanged: class 150 RF according to ASME B16.5 and ASME B16.42</li> <li>• ANSI Class 125 FF according to ASME B16.1, PN16/25 according to ISO 7005-1 and ISO 7005-2</li> <li>• Threaded: Rp EN 10226-1, NPT ASME B1.20.1 (2" only)</li> </ul>

Tab. 4.16

Coefficients Cg and K1 1"   DN 25							
Seat		6.5	9.5	12.7	19	25	32
Head	Coefficient						
BP/MP	Cg	50	92	161	253	-	-
	K1	98	91	97	93	-	-
TR	Cg	50	93	180	317	-	-
	K1	98	91	97	93	-	-

Tab. 4.17

Coefficients Cg and K1 1" 1/2   DN 40							
Seat		6.5	9.5	12.7	19	25	32
Head	Coefficient						
BP/MP	Cg	50	107	141	158	332	393
	K1	119	101	94	96	102	91
TR	Cg	50	107	170	307	429	530
	K1	119	101	94	91	85	85

Tab. 4.18

Coefficients Cg and K1 2"   DN 50							
Seat		6.5	9.5	12.7	19	25	32
Head	Coefficient						
BP/MP	Cg	50	107	151	171	346	440
	K1	115	101	93	89	86	86
TR	Cg	50	109	179	320	447	570
	K1	115	104	93	89	86	86

Tab. 4.19

#### 4.4.1 - VARIATION OF OUTLET PRESSURE AS INLET PRESSURE CHANGES BY 0.5 BAR

Springs (dimensions and colours)	HEADER Ø 280 BP/MP					
	Size [inches]					
	1/4"	3/8"	1/2"	3/4"	1"	1" 1/4
d= 3,2 De= 65 Lo= 180 2701175 White	0.2	0.4	0.5	1.3	2.4	3.4
d= 3,5 De= 65 Lo= 180 2701345 Yellow	0.2	0.4	0.5	1.3	2.4	3.4
d= 4 De= 65 Lo= 180 2701620 Orange	0.2	0.4	0.6	1.3	2.4	3.4
d= 4,5 De= 65 Lo= 180 2701860 Red	0.3	0.5	0.7	1.4	2.6	3.5
d= 5 De= 65 Lo= 180 2702190 Green	0.3	0.5	0.9	1.5	2.3	3.6
d= 5,5 De= 65 Lo= 180 2702370 Black	0.4	0.6	0.9	1.6	2.4	3.7
d= 6 De= 65 Lo= 180 2702540 Blue	0.4	0.7	1.1	1.9	2.6	3.8
d= 6,5 De= 65 Lo= 180 2702730 Light Blue	0.9	1	1.3	2.8	3.1	3.9
d= 7 De= 65 Lo= 180 2702950 Brown	1	1.1	1.5	3.5	3.7	4,6

**d** = Wire Diameter (mm)    **Lo** = Spring Length (mm)    **De** = External Diameter (mm)

Tab. 4.20

Springs (dimensions and colours)	HEADER Ø 280 TR					
	Size [inches]					
	1/4"	3/8"	1/2"	3/4"	1"	1" 1/4
d= 7 De= 65 Lo= 180 2702940 Light Blue	2	3	5	11	18	28
d= 7,5 De= 65 Lo= 180 2702125 White/Yellow	2	3	5	11	18	29
d= 8 De= 65 Lo= 180 2703325 White/Orange	2	3	6	11	18	29

**d** = Wire Diameter (mm)    **Lo** = Spring Length (mm)    **De** = External Diameter (mm)

Tab. 4.21

## 4.4.2 - SPRING SETTING RANGE

### 4.4.2.1 - INLET PRESSURE 1.7 BAR

Springs (dimensions and colours)	HEADER Ø 280 BP/MP											
	Size [inches]											
	1/4"		3/8"		1/2"		3/4"		1"		1" 1/4	
	Pd min	Pd max	Pd min	Pd max	Pd min	Pd max	Pd min	Pd max	Pd min	Pd max	Pd min	Pd max
d= 3,2 De= 65 Lo= 180 2701175 White	5	13	6	16	7	17	10	20	13	22	16	26
d= 3,5 De= 65 Lo= 180 2701345 Yellow	7	19	8	21	8	22	11	25	14	27	18	32
d= 4 De= 65 Lo= 180 2701620 Orange	10	32	12	34	12	34	15	38	19	40	22	45
d= 4,5 De= 65 Lo= 180 2701860 Red	15	53	17	55	18	56	21	60	25	62	25	67
d= 5 De= 65 Lo= 180 2702190 Green	23	80	24	83	24	84	29	89	32	90	36	97
d= 5,5 De= 65 Lo= 180 2702370 Black	38	127	41	129	43	131	48	143	48	142	52	147
d= 6 De= 65 Lo= 180 2702540 Blue	50	173	53	178	55	179	56	188	61	191	65	197
d= 6,5 De= 65 Lo= 180 2702730 Light Blue	81	280	82	280	82	287	88	299	94	303	98	306
d= 7 De= 65 Lo= 180 2702950 Brown	95	372	100	380	105	386	110	395	113	401	120	404

**d** = Wire Diameter (mm)    **Lo** = Spring Length (mm)    **De** = External Diameter (mm)

Tab. 4.22

### 4.4.2.2 - INLET PRESSURE 3.4 BAR

Springs (dimensions and colours)	HEADER Ø 280 TR											
	Size [inches]											
	1/4"		3/8"		1/2"		3/4"		1"		1" 1/4	
	Pd min	Pd max	Pd min	Pd max	Pd min	Pd max	Pd min	Pd max	Pd min	Pd max	Pd min	Pd max
d= 7 De= 65 Lo= 180 2702940 Light Blue	164	753	170	778	188	779	207	807	259	844	261	863
d= 7,5 De= 65 Lo= 180 2702125 White/Yellow	292	1150	317	1160	324	1156	351	1170	365	1194	380	1216
d= 8 De= 65 Lo= 180 2703325 White/Orange	357	1391	369	1402	347	1403	385	1412	400	1430	458	1454

**d** = Wire Diameter (mm)    **Lo** = Spring Length (mm)    **De** = External Diameter (mm)

Tab. 4.23

## 4.5 - POSSIBLE CONFIGURATIONS

### 4.5.1 - CONTROL HEADS

“Tab. 4.24” lists the possible combinations of sizes and control heads for the equipment DIVAL 700.

		Size [inches]   DN [mm]		
		1"   25	1" ½   40	2"   50
T E S T A T E	BP / MP	Yes	Yes	Yes
	TR	Yes	Yes	Yes

Tab. 4.24

### 4.5.2 - ACCESSORIES

The DIVAL 700 equipment can have different configurations through the installation of the following accessories:

- Regulator with monitor function
- LA incorporated slam-shut valve.

The possible configurations are listed in “Tab. 4.25”:

DIVAL 700	Regulator-monitor	LA
Regulator-monitor	-	Yes
LA incorporated slam-shut valve	Yes	-

Tab. 4.25

The accessories can be installed directly at the factory or, at a later time, directly on site.

#### NOTICE!

**The installation of accessories is described in the relevant chapter of this manual.**

### 4.5.3 - REGULATOR WITH MONITOR FUNCTION

The regulator with monitor function (1) is used to keep the downstream pressure value ( $P_d$ ) within the preset limits in case of failure of the main regulator.

The regulator with monitor function is installed upstream of the main pressure regulator.

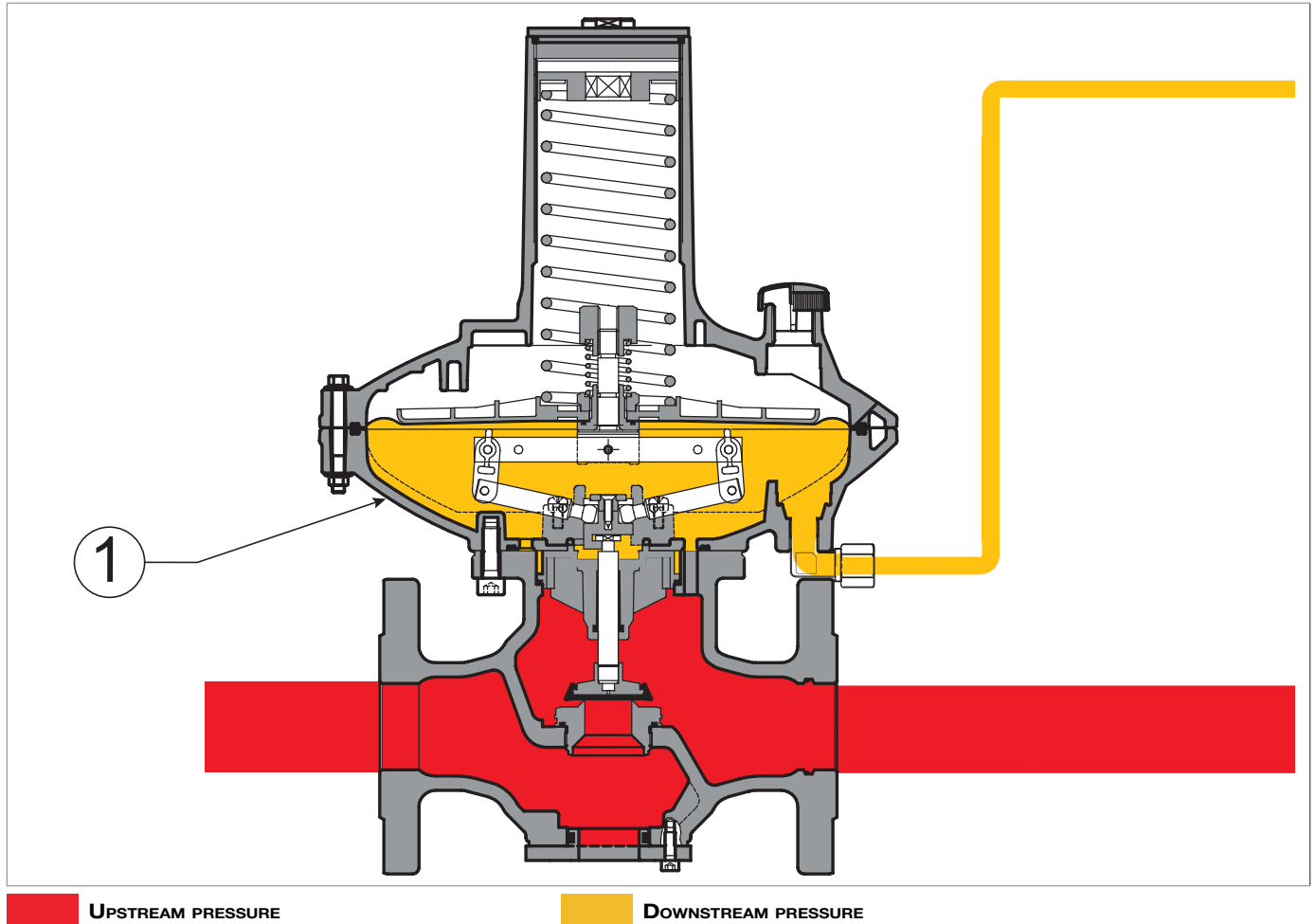

Fig. 4.3. Regulator with monitor function

**OPERATION IN STAND-BY CONDITIONS**

The regulator with monitor function is open during normal operation since it is calibrated higher than the calibration of the main regulator (2).

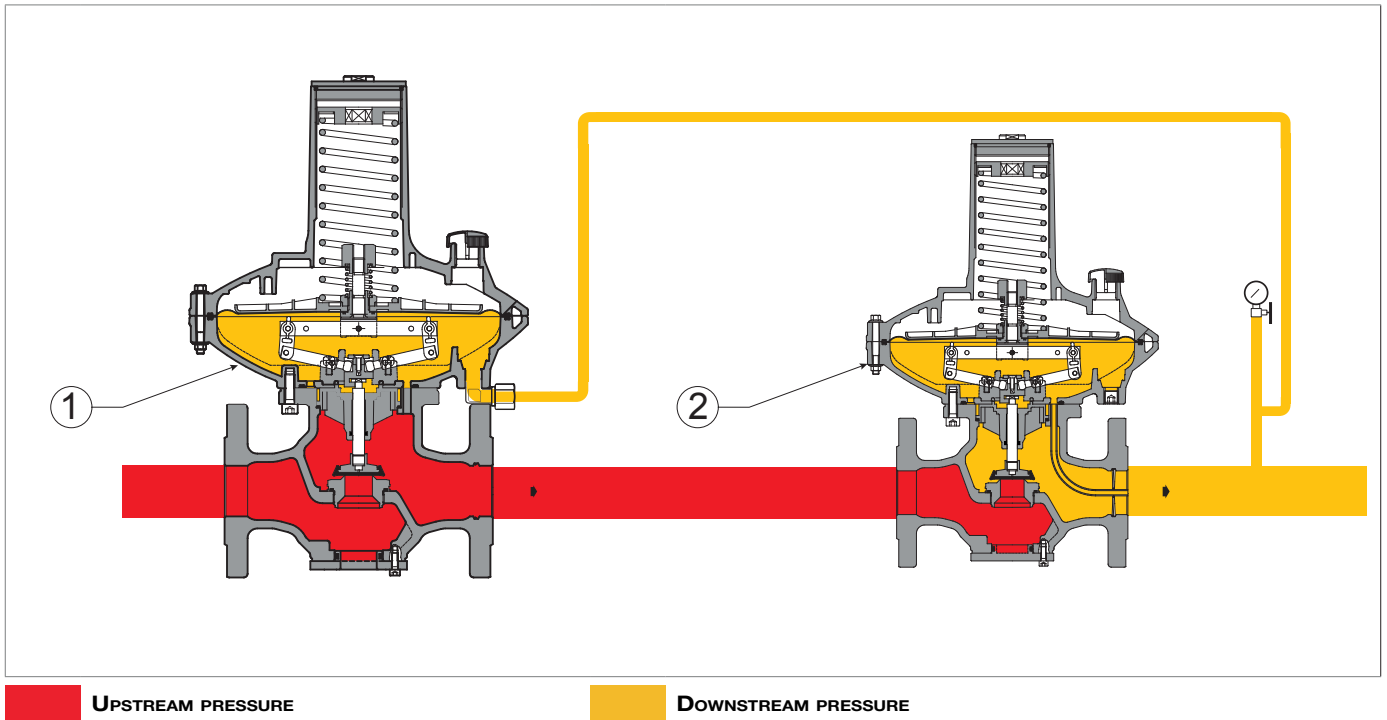
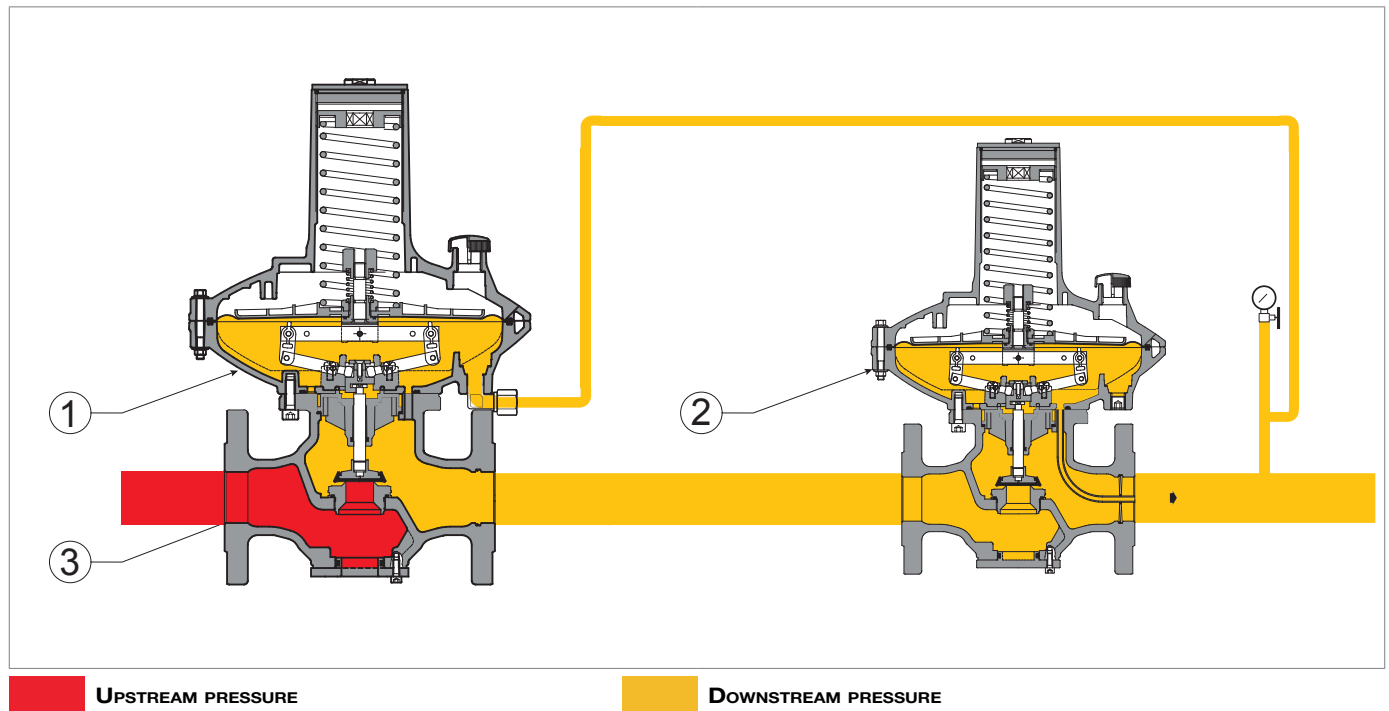

Fig. 4.4. In-line operation of regulator-monitor in stand-by conditions

## OPERATION IN THE EVENT OF FAILURE OF THE MAIN REGULATOR



UPSTREAM PRESSURE

DOWNSTREAM PRESSURE

Fig. 4.5. Operation of regulator-monitor with main regulator in faulty conditions

In the event of failure of the main regulator (2), the regulator with monitor function (1) will intervene maintaining the downstream pressure value ( $P_d$ ) within the established limit for its calibration.

If, during operation, the following should occur:

Operating conditions	Operating consequences	Concluding outcome
<b>Decrease in downstream pressure (<math>P_d</math>) for:</b> <ul style="list-style-type: none"> <li>increase in the requested flow rate;</li> <li>drop in pressure upstream (<math>P_u</math>).</li> </ul>	Unbalance that causes the plug (3) to open.	Increase in flow until the preset value of the downstream pressure ( $P_d$ ) is restored.
<b>Increased downstream pressure (<math>P_d</math>) due to:</b> <ul style="list-style-type: none"> <li>drop in the requested flow rate;</li> <li>increase in pressure upstream (<math>P_u</math>).</li> </ul>	Unbalance that causes the plug (3) to close.	Decrease in flow rate until the preset value of downstream pressure ( $P_d$ ) is restored.

Tab. 4.26

#### **4.5.4 - SLAM-SHUT VALVE**

The slam-shut valve is a safety device is used to shut off the gas flow if the pressure value at the control point exceeds the calibration value of the valve itself.

The slam-shut valve incorporated in the regulator consists of:

- a control system;
- the slam-shut device mechanism.

In the event of tripping, the slam-shut valve shuts off the supply to the regulator.



#### 4.5.4.1 - LA INCORPORATED SLAM-SHUT VALVE

The LA incorporated slam-shut valve can be operated:

- by the intervention spring
- manually.

The main features of the LA incorporated slam-shut valve are:

- tripping due to downstream pressure increase and/or decrease;
- design pressure: 20 bar for all accessory components;
- local close button (can be omitted on request).

Slam-shut valve type		Set	Operating range (bar)	AG
LA	BP	max	0.03 - 0.18	10
		min	0.006 - 0.06	30
LA	MP	max	0.14 - 0.179	10
			0.18 - 0.45	5
		min	0.01 - 0.059	30
			0.06 - 0.24	10
LA	TR	max	0.25 - 1.29	10
			1.3 - 5.5	5
		min	0.1 - 3.5	10

Tab. 4.27

The incorporated LA slam-shut valve consists of (see Fig. 4.6):

Pos.	Description		
1	Plug pad	6	Tripping spring due to pressure increase
2	Reset knob	7	Tripping spring due to pressure decrease
3	Coupling device	8	Spring support
4	Rod	9	Control shaft
5	Diaphragm	10	Sensor

Tab. 4.28

### OPERATION

In the control head (C), the downstream pressure (Pd) acts on the diaphragm (5), which, integral with the control shaft (9), receives an antagonistic force via the springs (6, 7), which causes the pressure to rise or fall.

In the event of tripping due to a pressure surge:

- the downstream pressure (Pd) exceeds the calibration value
- the load on the diaphragm (6) increases until the resistance of the spring (6) is overcome
- movement to the open position of the drive shaft (9) moves the touch probe (10) via the cam, disengaging the lever mechanism.

In the event of a tripping due to pressure drop:

- the downstream pressure (Pd) drops below the calibration value
- the spring holder (7) stops the stroke
- movement to the closed position of the drive shaft (9) moves the touch probe (10) via the cam, disengaging the lever mechanism.

To reset the LA slam-shut valve:

- pull the reset knob (2) downwards until the lever mechanism is reengaged
- wait for the upstream pressure (Pu) to pass downstream of the plug (1), balancing it
- press the reset knob (2) into its seat.

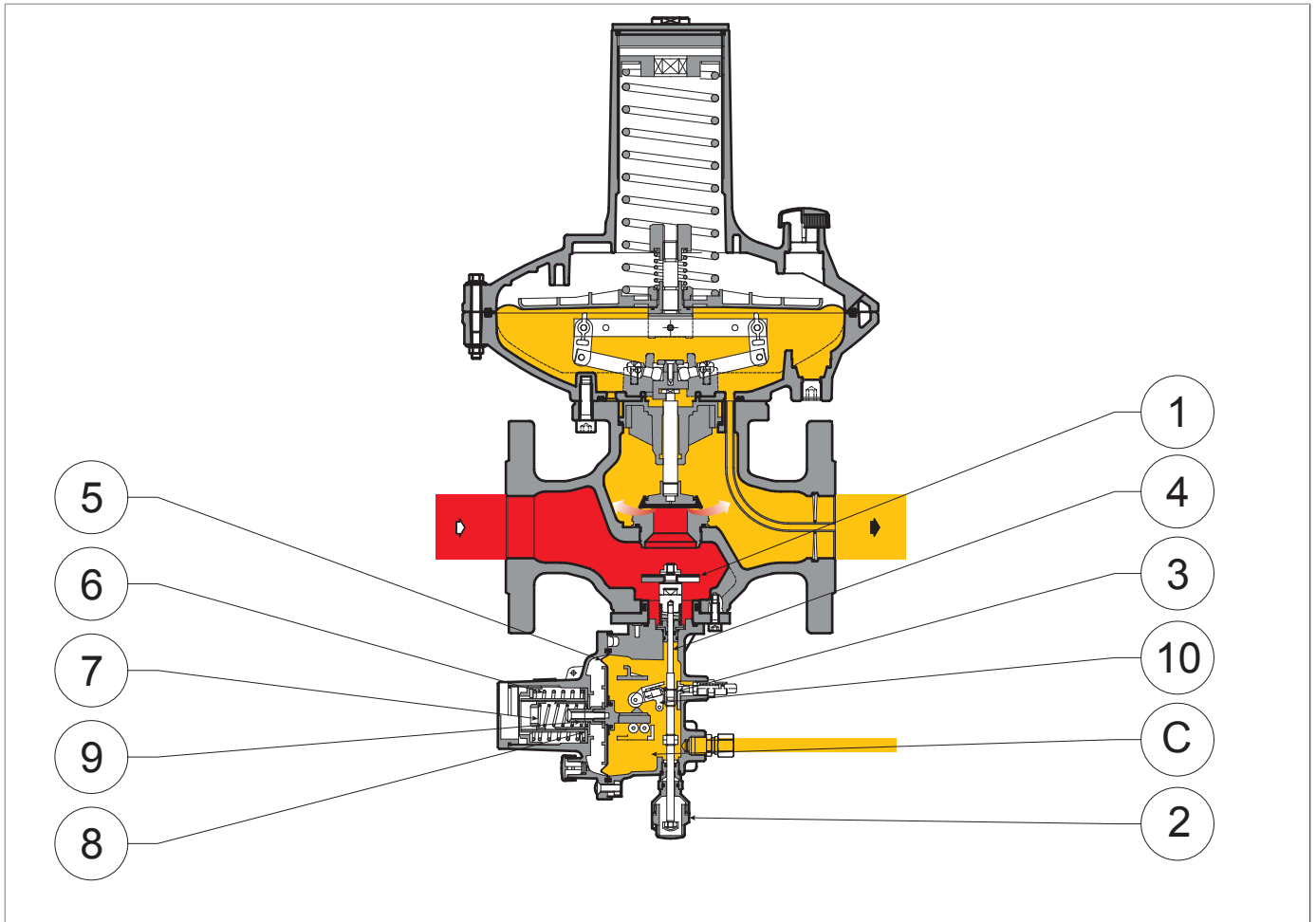

**UPSTREAM PRESSURE**      **DOWNSTREAM PRESSURE**

Fig. 4.6. DIVAL 700 with incorporated LA slam-shut valve

## 5 - TRANSPORT AND HANDLING

### 5.1 - SPECIFIC WARNINGS FOR TRANSPORT AND HANDLING

#### NOTICE!

Transport and handling must be carried out by personnel:

- qualified (specially trained);
- who are familiar with accident prevention and workplace safety regulations;
- authorised to use lifting equipment;
- in compliance with the regulations in force in the country of destination of the equipment.

#### Transport with forklift or crane

<b>Operator qualification</b>	Person in charge of transport, handling, unloading and placing on site
<b>PPE required</b>	 <p><b>WARNING!</b></p> <p>The PPE listed in this table is related to the risk associated with the equipment. For the PPE required to protect against risks associated with the workplace, installation or operating conditions, please refer to:</p> <ul style="list-style-type: none"> <li>• the regulations in force in the country of installation;</li> <li>• <u>any information provided by the Safety Manager at the installation facility.</u></li> </ul>
<b>Lifting equipment</b>	Hoist crane, forklift truck or other suitable equipment.
<b>Weights and dimensions of the equipment</b>	For dimensions and weights please refer to “5.2 - Physical characteristics of the equipment”.

Tab. 5.29

### 5.1.1 - PACKAGING AND FASTENERS USED FOR TRANSPORT

The transport packaging is designed and manufactured to avoid damage during normal transport, storage and handling. The equipment and spare parts must be kept in their packaging until they are installed.



Upon receiving the equipment:

- make sure that no part has been damaged during transport and/or handling;
- immediately report any damage found to PIETRO FIORENTINI S.p.A..

**! NOTICE!**

**PIETRO FIORENTINI S.p.A. shall not be liable for any damage to people or property caused by accidents due to failure to comply with the instructions provided in this manual.**

“Tab. 5.30” shows the types of packaging used:

Ref.	Type of packaging	Image
A	Cardboard box	
B	Wooden box	
C	Pallet	

Tab. 5.30



## 5.2 - PHYSICAL CHARACTERISTICS OF THE EQUIPMENT

### 5.2.1 - DIVAL 700

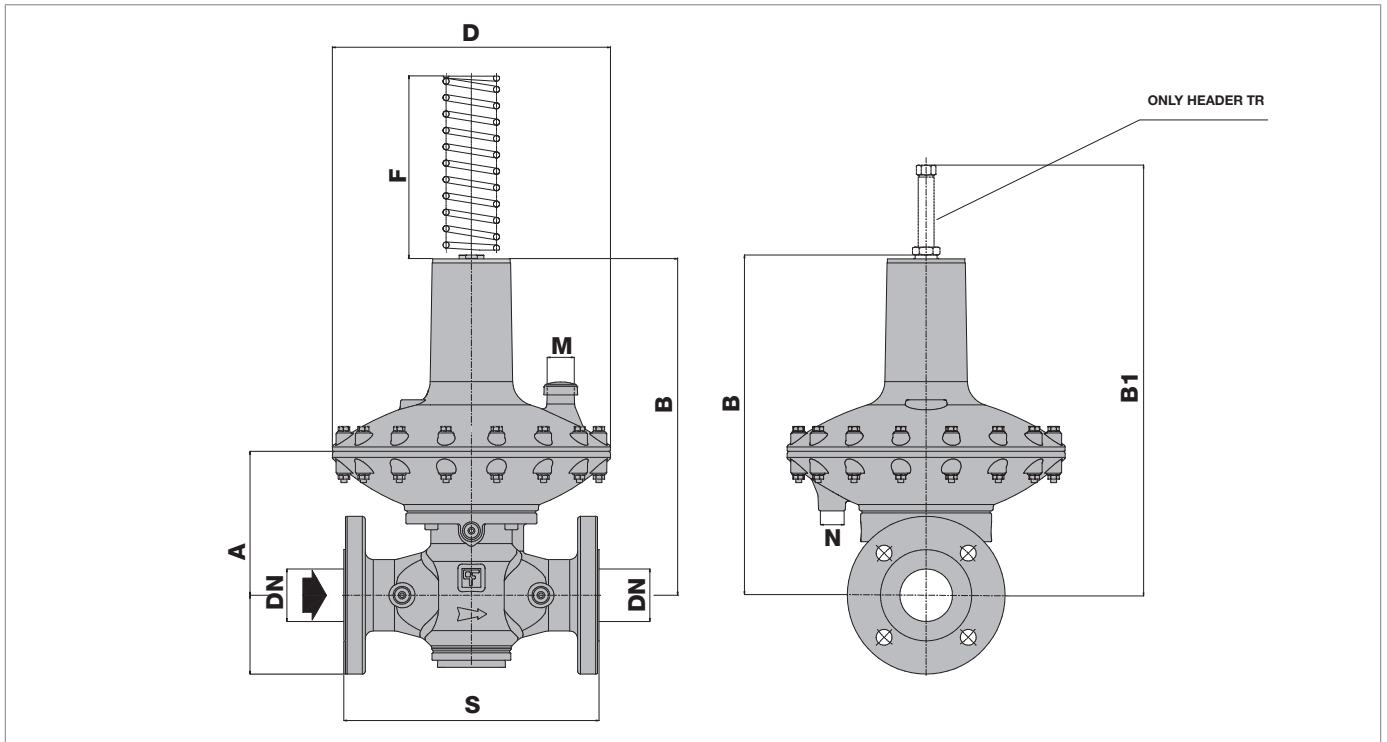

Fig. 5.7. DIVAL 700 physical characteristics

DIVAL 700 overall dimensions				
Size [inches]	1"	1" ½	2"	Rp 2"x 2"
Nominal diameter [mm]	25	40	50	50
S	183	223	254	152.4
A	145	145	145	145
B	343	343	343	343
B1	433	433	433	433
D	280	280	280	280
F	200	200	200	200
M	Rp 1/2"	Rp 1/2"	Rp 1/2"	Rp 1/2"
Connecting pneumatic connections	Øe 10mm x Øi 8mm			

Tab. 5.31

DIVAL 700				
Weight [kgf]	15	17	20	18

Tab. 5.32

## 5.2.2 - DIVAL 700 + LA

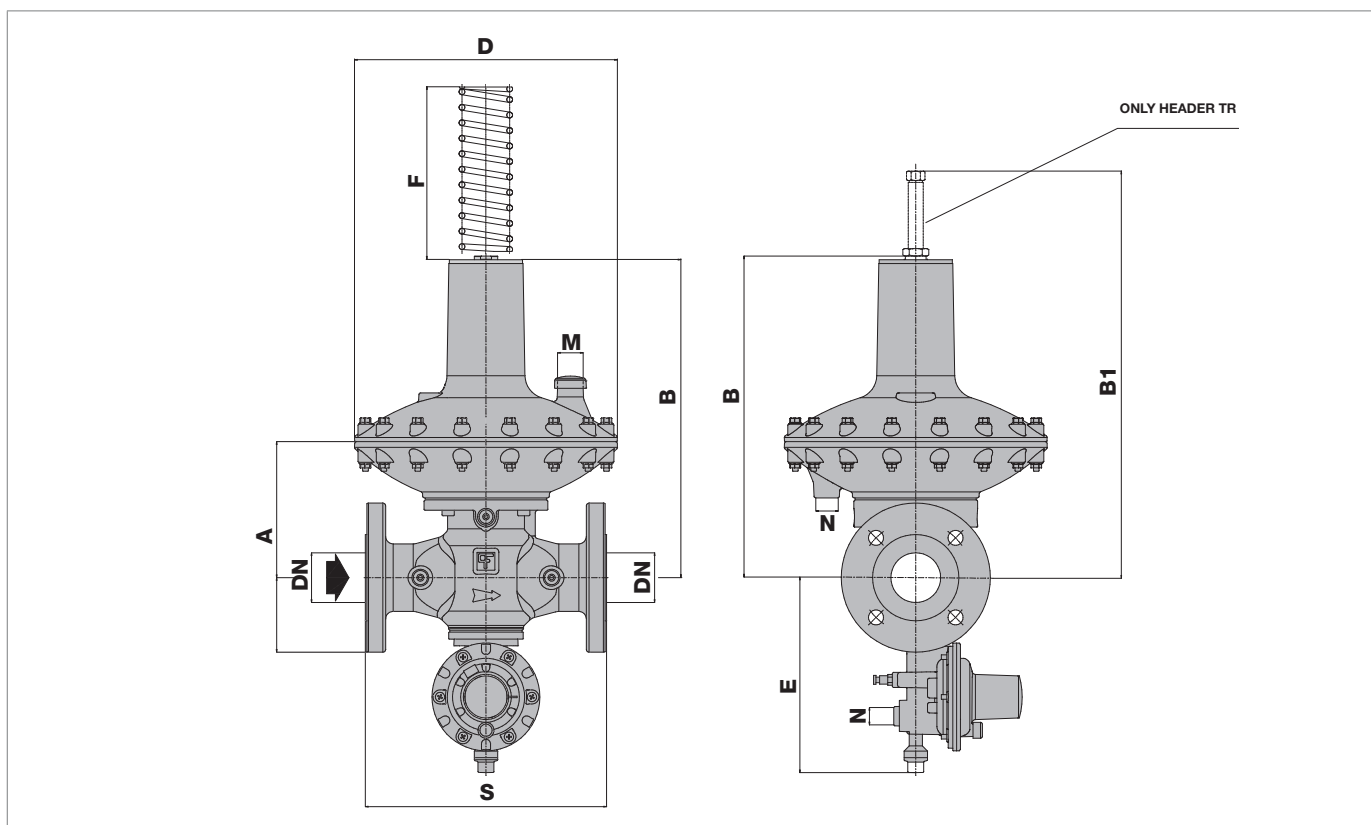

Fig. 5.8. Physical characteristics DIVAL 700 + LA

Overall dimensions DIVAL 700 + LA				
Size [inches]	1"	1" ½	2"	Rp 2" x 2"
Nominal diameter [mm]	25	40	50	50"
S	183	223	254	152.4
A	145	145	145	145
B	343	343	343	343
B1	433	433	433	433
D	280	280	280	280
E	215	215	215	215
F	200	200	200	200
M	Rp 1/2"	Rp 1/2"	Rp 1/2"	Rp 1/2"
N	Rp 1/4"	Rp 1/4"	Rp 1/4"	Rp 1/4"
Connecting pneumatic connections	Øe 10mm x Øi 8mm			

Tab. 5.33

DIVAL 700 + LA				
Weight [kgf]	16	18	21	19

Tab. 5.34

### 5.3 - EQUIPMENT ANCHORING AND LIFTING METHOD

 **HAZARD!**

**Before moving the equipment, make sure that the capacity of the lifting equipment is suitable for the load.**

 **WARNING!**

Unloading, transport and handling activities must be carried out by operators qualified and specially trained:

- on accident prevention rules;
- on maximum safety in the workplace;
- on the use of lifting equipment.

 **ATTENTION!**

Before moving the equipment:

- remove any movable or hanging component or firmly secure it to the load;
- protect fragile equipment;
- check that the load is stable.



### 5.3.1 - FORKLIFT HANDLING METHOD

**HAZARD!**

It is forbidden to:

- Do not transit under suspended loads;
- Do not move the load over the personnel operating in the site/plant area.

**WARNING!**





The following is not allowed on forklifts:

- carrying passengers;
- lifting people.

**NOTICE!**

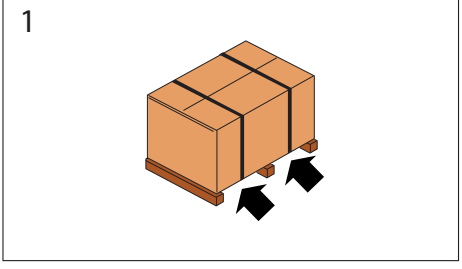
Packaging must always be handled in a vertical position

Proceed as described at "Tab. 5.35":

Step	Action	Image
1	Place the forks of the forklift under the load surface.	<p>1</p> 
2	Make sure that the forks protrude from the front of the load (by at least 5 cm), far enough to eliminate any risk of the transported load tipping.	<p>2</p> 
3	<p>Raise the forks until they are touching the load.</p> <div style="border: 1px solid blue; padding: 5px; margin-top: 10px;"> <p><b>NOTICE!</b> Fasten the load to the forks with clamps or similar devices if required.</p> </div>	<p>3</p> 
4	Slowly lift the load by a few dozen centimetres and check its stability, making sure that the centre of gravity of the load is positioned at the centre of the lifting forks.	<p>4</p> 

DIVAL 700

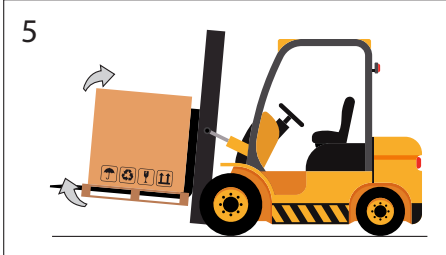
Step	Action	Image
5	Tilt the mast backwards (towards the driver's seat) to help the over-turning moment and to ensure greater load stability during transport.	
6	Adjust transport speed according to the type of floor and load, avoiding sudden manoeuvres. <b>⚠ WARNING!</b> <b>In case of:</b> <ul style="list-style-type: none"> <li>• <b>obstacles along the path;</b></li> <li>• <b>particular operating situations;</b></li> </ul> <b>hinder operator visibility, the assistance of a ground operator is required, standing outside the range of action of the lifting equipment, with the task of signalling.</b>	-
7	Place the load in the chosen installation area.	-

Tab. 5.35

### 5.3.2 - CRANE HANDLING METHOD

#### **WARNING!**

It is mandatory to use CE marked chains, ropes and eyebolts or marked with conformity marks/markings in accordance with the regulations in force in the place of installation. Do not use chains connected to each other by bolts.

Always check that:

- the safety catch of the hook returns to the initial position;
- the ropes are in excellent condition and have adequate sections.



It is forbidden to:

- drag the load on the ground;
- operate near power lines;
- stand within the range of action of the crane.

#### **NOTICE!**

**Packaging must be always handled in a vertical position.**

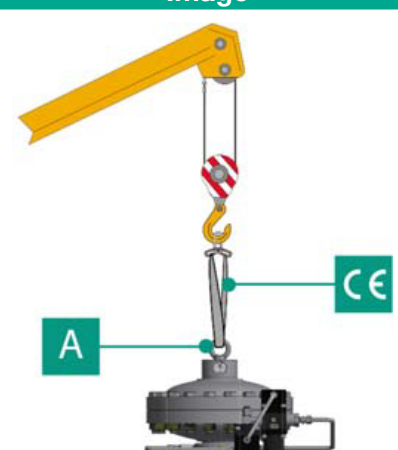
The equipment must be handled using the lifting points provided on the equipment itself. For proper transport, follow the procedure in "Tab. 5.36":

Step	Action	Image
1	Attach the lifting rope or chain to the appropriate supports.  <b>WARNING!</b> <b>The lifting point is sized for lifting only the equipment, and not other parts of the system connected to it.</b>	
2	Slightly lift the load making sure the ropes or chains are secure.  <b>NOTICE!</b> <b>Check whether the load is properly balanced.</b>	
3	Handle the load avoiding sudden movements.	
4	Place the load in the chosen installation area.	

Tab. 5.36

## 5.4 - PACKAGING REMOVAL

Packaging removal	
<b>Operator qualification</b>	<ul style="list-style-type: none"> <li>Person in charge of transport, handling, unloading and placing on site;</li> <li>Installer.</li> </ul>
<b>PPE required</b>	<div style="display: flex; align-items: center;">  <div style="margin-left: 10px;"> <p><b>⚠ WARNING!</b></p> <p>The PPE listed in this table is related to the risk associated with the equipment. For the PPE necessary to protect against risks associated with the workplace or operating conditions, please refer to:</p> <ul style="list-style-type: none"> <li>the regulations in force in the country of installation;</li> <li>any information provided by the Safety Manager at the installation facility.</li> </ul> </div> </div>

Tab. 5.37

To unpack the equipment in a cardboard box, proceed as described in “Tab. 5.38”:

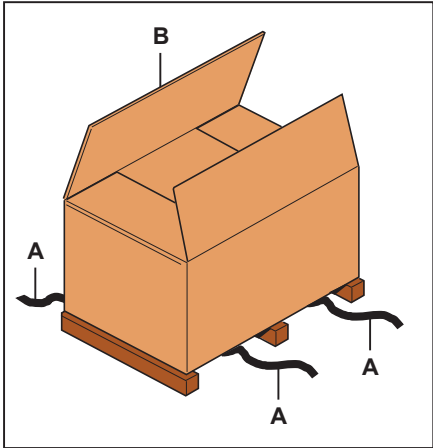
Step	Action	Image
1	Remove the straps (A).	
2	Remove the packaging cardboard (B).	
3	Remove the fasteners that secure the equipment to the base (if any).	
4	<p>Move the equipment from the base to the place intended for it.</p> <div style="border: 1px solid blue; padding: 5px;"> <p><b>⚠ NOTICE!</b></p> <p>Have at least 2 operators manually move the equipment, if required due to its dimensions/weight.</p> </div>	

Tab. 5.38

### ⚠ NOTICE!

After removing all packaging materials, check for any anomalies.

If there are anomalies:

- do not install the equipment;
- contact PIETRO FIORENTINI S.p.A. and specify the details provided on the equipment nameplate.

### 5.4.1 - PACKAGING DISPOSAL

### ⚠ NOTICE!

Sort the various materials making up the packaging and dispose of them in compliance with the regulations in force in the country of installation.

## 5.5 - STORAGE AND ENVIRONMENTAL CONDITIONS

If the equipment needs to be stored for an extended period, the minimum environmental conditions for the intended storage are provided. Only by complying with these requirements can the declared performance be guaranteed:

Conditions	Data
Maximum storage period	Maximum 3 years. <div style="border: 1px solid black; padding: 5px;">  <b>NOTICE!</b>  <b>For installations in later periods, see paragraph “5.5.1 - Pre-installation warnings after prolonged storage”.</b> </div>
Temperature	Not above 40°C
Humidity	Not above 70%
Radiation	Away from radiation sources according to UNI ISO 2230:2009

Tab. 5.39

### 5.5.1 - PRE-INSTALLATION WARNINGS AFTER PROLONGED STORAGE

For installations that have been stored for longer than 3 years, the condition of all rubber parts must be checked and, if found to be damaged, they must be replaced in order to ensure the correct functioning of the equipment.

For the replacement of the rubber parts of the equipment, please refer to “9 - Maintenance and functional checks”.

<div style="border: 1px solid black; padding: 5px;">  <b>NOTICE!</b>  <b>PIETRO FIORENTINI S.p.A. recommends checking the condition of rubber parts in case of downtime or storage longer than 3 years.</b> </div>
---------------------------------------------------------------------------------------------------------------------------------------------------------------------------------------------------------------------------------------------------------------------------------------------------------



## 6 - INSTALLATION

### 6.1 - INSTALLATION PRE-REQUISITES

#### 6.1.1 - ALLOWED ENVIRONMENTAL CONDITIONS

##### WARNING!

**To safely use the equipment, in full respect of the allowed environmental conditions, follow the data shown on the regulator plate and on any accessories (refer to paragraph “2.8 - Applied rating plates”).**

The installation site must be suitable for the safe use of the equipment.

The installation area of the equipment must be properly lit to ensure proper operator visibility during working on the equipment.

##### NOTICE!

**The equipment must operate in places that are properly lit by artificial lighting suitable for the protection of the operator (in compliance with UNI EN 12464-1:2011 and UNI EN 12464-2:2014). If maintenance work is to be performed in areas and/or parts that are poorly lit, it is mandatory to:**

- use all the light sources of the installation plant;
- be equipped with a handheld lighting system or connected to the power mains, compliant with Directive 2014/34/EU (ATEX) for use in environments at risk of explosion.

## 6.1.2 - CHECKS BEFORE INSTALLATION

The equipment does not require any further upstream safety device for protection against any overpressure with respect to its **PS admissible pressure** when, for the upstream reduction station, the maximum incidental downstream pressure is:

$$\text{MIPd} \leq 1.1 \text{ PS}$$

**MIPd** = Maximum incidental downstream pressure value (for further information, see UNI EN 12186:2014).

### **ATTENTION!**

**If the installation of the equipment requires the application of compression fittings, these must be installed in accordance with the instructions of the Manufacturer of the fittings themselves.**



**The choice of fittings must be compatible with:**

- **the use specified for the equipment;**
- **the plant specifications when required.**

Before installation, it must be ensured that:

- the expected dimensions of the installation site are compatible with those of the equipment;
- there are no impediments for the workers in charge of maintenance;
- the upstream and downstream pipes are at the same level and can bear the weight of the equipment;
- the inlet and outlet connections of the pipes are aligned on the flanges;
- the inlet and outlet connections of the equipment are clean and flawless;
- the inside of the upstream pipe is clean and free of processing residues such as welding slag, sand, paint residues, water, etc...

### Installation

<b>Operator qualification</b>	Installer
<b>PPE required</b>	 <p><b> WARNING!</b></p> <p><b>The PPE listed in this table is related to the risk associated with the equipment. For the PPE required to protect against risks associated with the workplace, installation or operating conditions, please refer to:</b></p> <ul style="list-style-type: none"> <li>• <b>the regulations in force in the country of installation;</b></li> <li>• <b>any information provided by the Safety Manager at the installation facility.</b></li> </ul>
<b>Equipment required</b>	Please refer to the chapter "7 - Commissioning/maintenance equipment".

Tab. 6.40



## 6.2 - SPECIFIC SAFETY INSTRUCTIONS FOR THE INSTALLATION STEP

 **WARNING!**

Before proceeding with installation, make sure that the upstream and downstream valves installed on the line are shut off.

---

 **WARNING!**

Installation may also take place in areas where there is a risk of explosion, which implies that all necessary prevention and protection measures have to be taken.

For these measures, please refer to the regulations in force at the place of installation.

---

### 6.3 - GENERAL INFORMATION ON CONNECTIONS

The equipment must be installed in-line with an arrow on the body pointing to the gas flow direction.  
In line installation, there must be (see Fig. 6.9 and 6.10):

Pos.	Description
1	1 <b>shut-off valve upstream</b> of the equipment.
2	2 <b>vent valves</b> one upstream and one downstream of the equipment.
3	2 <b>pressure gauges</b> one upstream and one downstream of the equipment.
4	1 <b>pressure regulator</b> .
5	1 <b>shut-off valve downstream</b> of the equipment.

Tab. 6.41

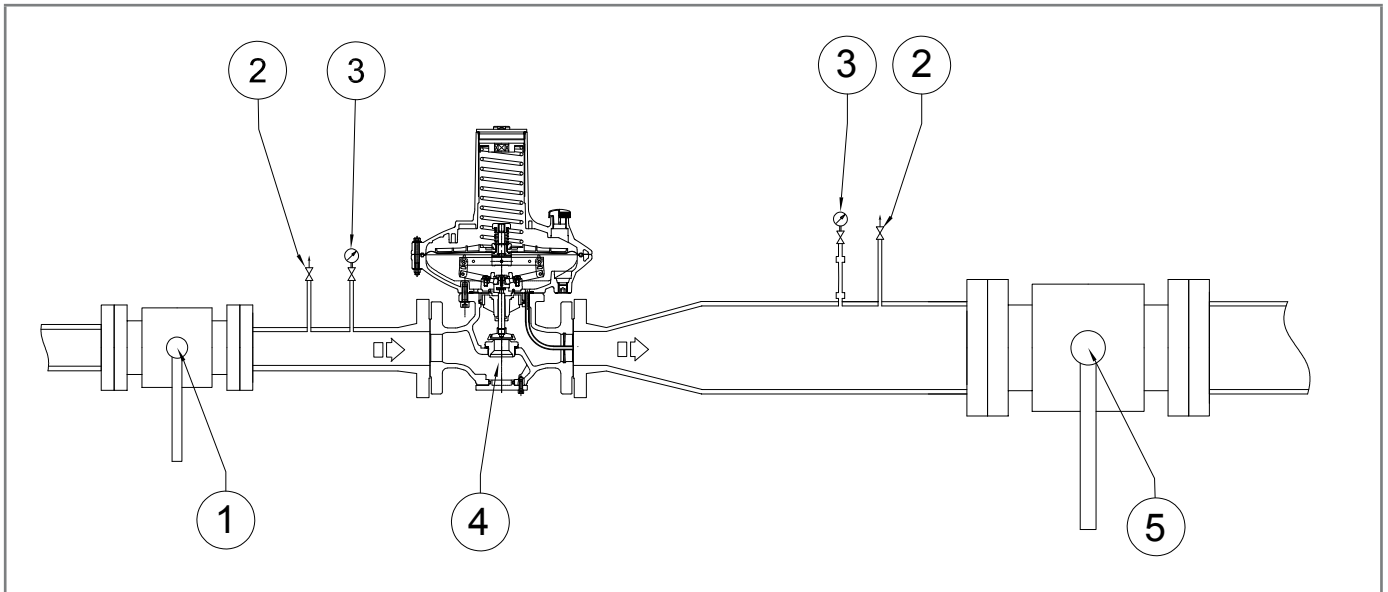

Fig. 6.9. In-line installation

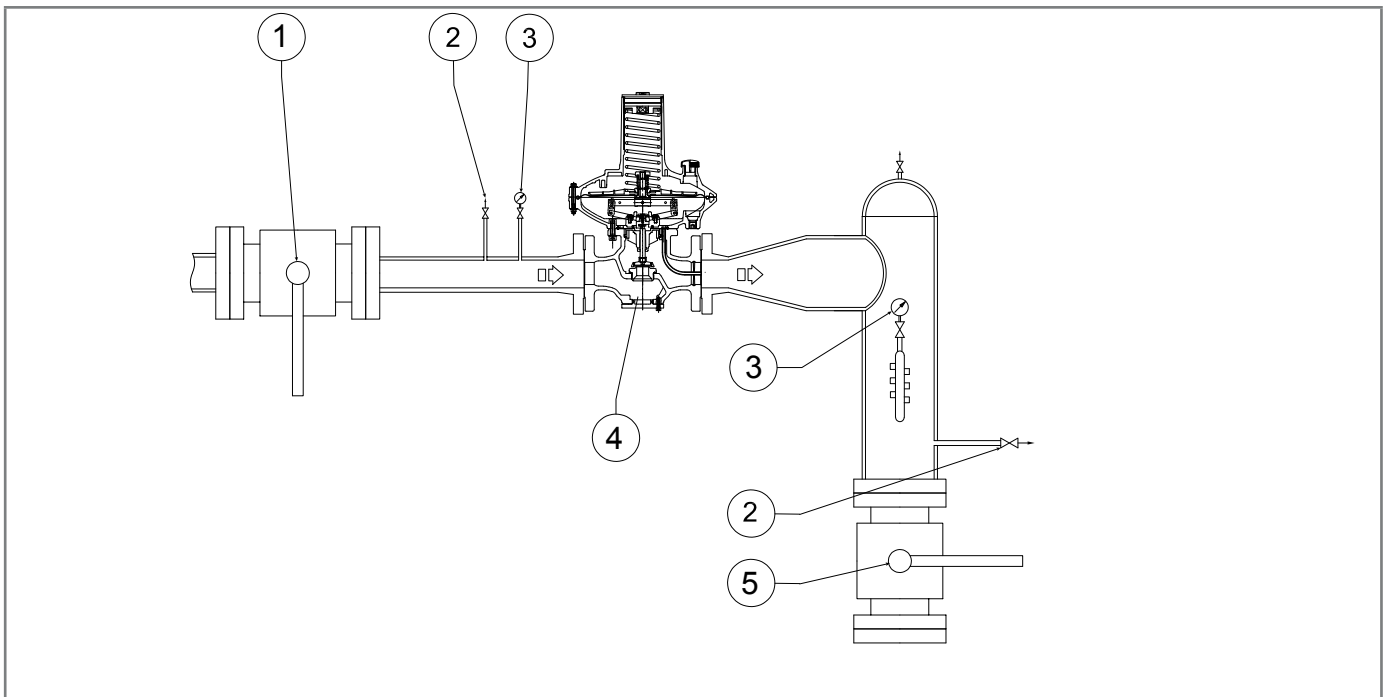

Fig. 6.10. Angle installation

**! NOTICE!**

When used in gas pressure reduction stations, the device must be installed at least according to the requirements of standards UNI EN 12186:2014 or UNI EN 12279:2007.

Equipment vents must be ducted in accordance with UNI EN 12186:2014 or UNI EN 12279:2007 or the standards in force at the place of installation of the equipment.

## 6.4 - REGULATOR INSTALLATION POSITIONS

Figure 6.11 and 6.12 illustrate typical regulator arrangements:

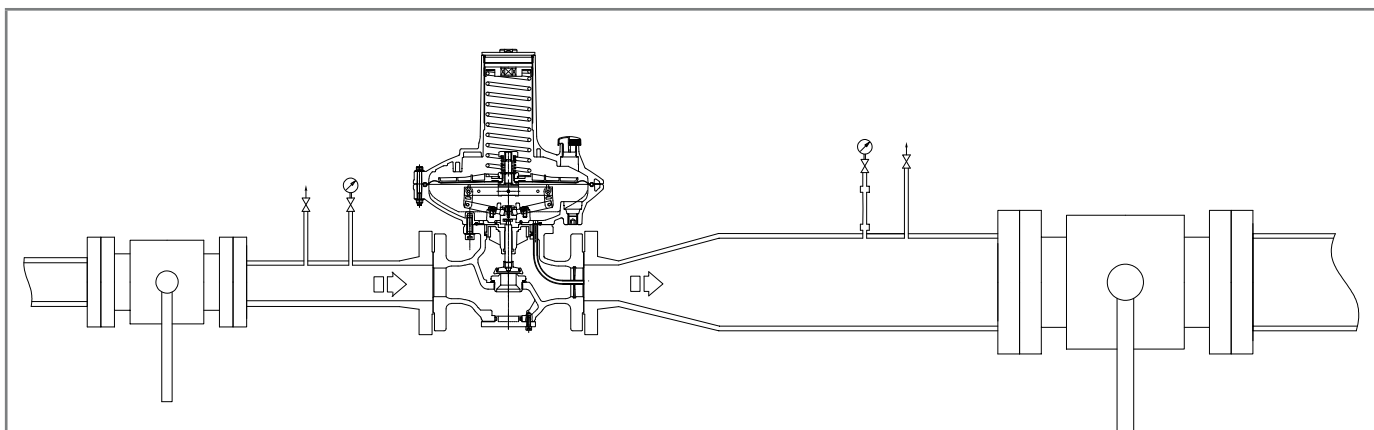

Fig. 6.11. Standard position

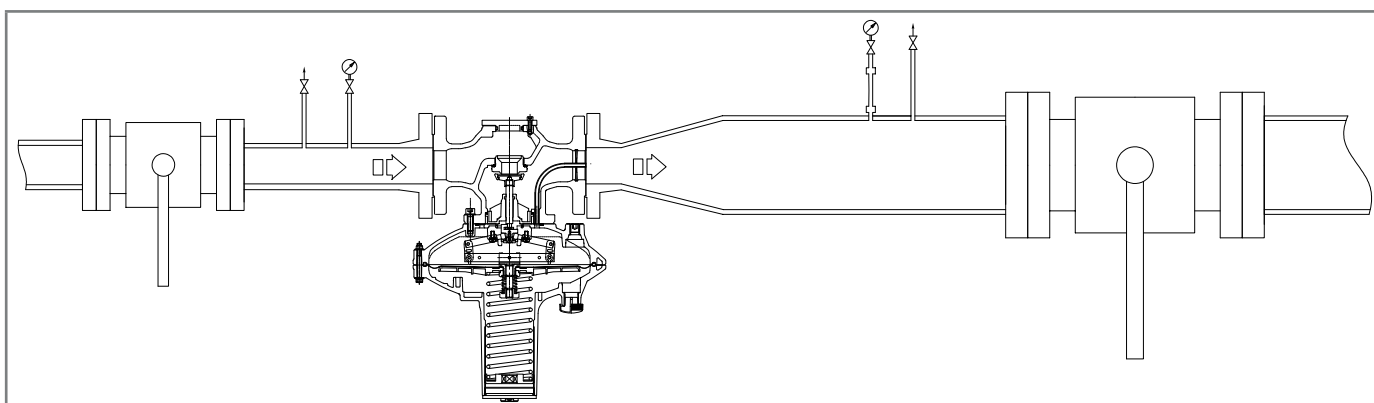

Fig. 6.12. Inverted position

## 6.5 - INSTALLATION PROCEDURES

### 6.5.1 - EQUIPMENT INSTALLATION PROCEDURES

Step	Action
1	Place the equipment in the section of the line designated for it.
2	Place the gaskets between the line flanges and the regulator flanges.
3	Insert the bolts into the appropriate holes of the connecting flanges.
4	Screw the bolts following the technical rules for tightening flanges.

Tab. 6.42

#### NOTICE!

For installation after maintenance, replace the seals.

### 6.5.2 - CONNECTION OF THE SENSING LINES TO THE DOWNSTREAM PIPING

For the Dival 700 equipment the sensing lines are internal (Fig. 6.13), for the Dival 700 with inline monitor function the sensing lines are external (Fig. 6.14).

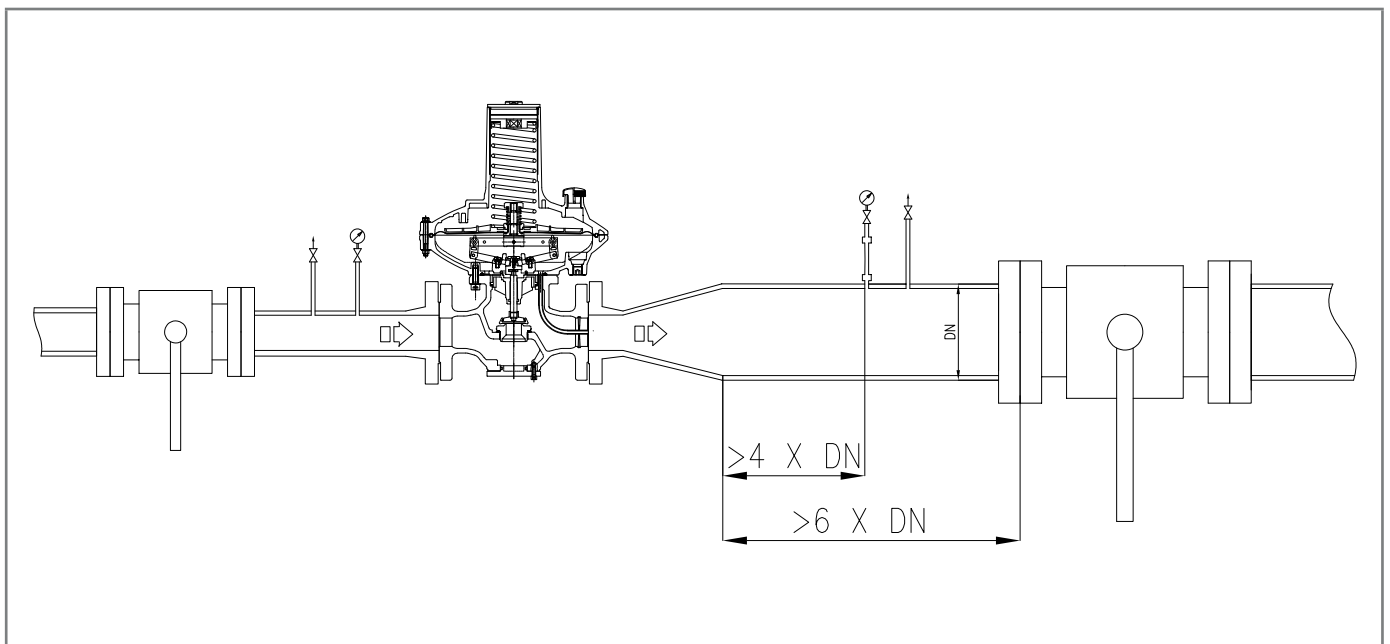

Fig. 6.13. Connection of sensing lines to the downstream piping DIVAL 700

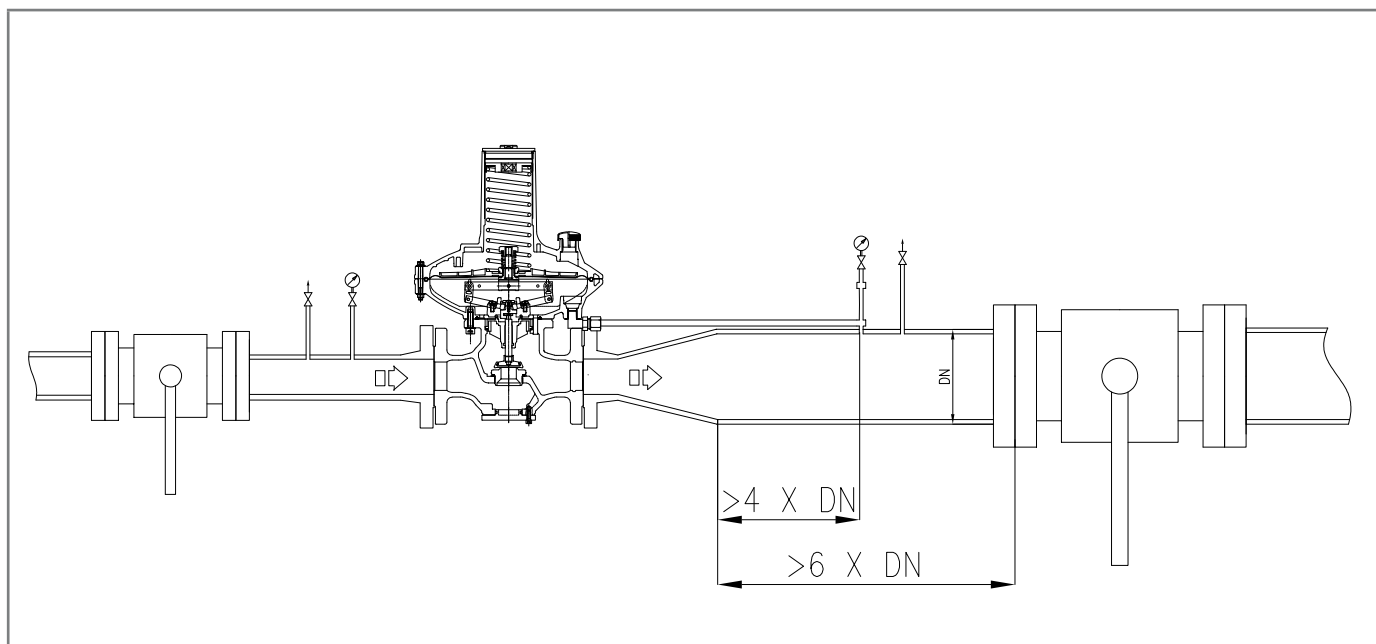

Fig. 6.14. Sensing line connection to downstream pipeline DIVAL 700 with monitor function

For proper adjustment, it is essential that:

- the downstream shut-off valve is placed at a distance of at least 6 times the nominal diameter of the pipe downstream of the regulator;
- the downstream sensing lines are placed on a straight section of pipe (with uniform diameter) having a length equal to at least 4 times the rated diameter of the pipe itself;

For optimum performance, the velocity of the pressurised fluid at the sampling point does not exceed the following values:

$$V_{\max} = 30 \text{ m/s for } P_a > 5 \text{ bar}$$

$$V_{\max} = 25 \text{ m/s for } P_a < 5 \text{ bar}$$

As a limit for use, the velocity of the fluid under pressure at the point of pick-up does not exceed the following value:

$$V_{\max} = 40 \text{ m/s for } P_a > 5 \text{ bar}$$

To calculate the flow rate, use the following formula:

$$V = 345,92 \times \frac{Q}{DN^2} \times \frac{1 - 0,002 \times Pd}{1 + Pd}$$

**V** = gas velocity in m/sec

**Q** = gas flow rate Sm<sup>3</sup>/h

**DN** = nominal pipe diameter in mm

**Dp** = regulator outlet pressure in barg

**NOTICE!**

**All on-site pneumatic connections must have pipes with a minimum internal diameter of 8 mm.**

To prevent the pneumatic connections of the sensing lines from collecting impurities and condensation, it is necessary that:

- the connections of the pneumatic connection are always welded to the top or horizontal axis of the pipe itself (refer to Fig. 6.14);
- the hole in the piping has no burrs or internal protrusions;
- the slope of the pneumatic connection is always 5-10% towards the downstream pipe connection.

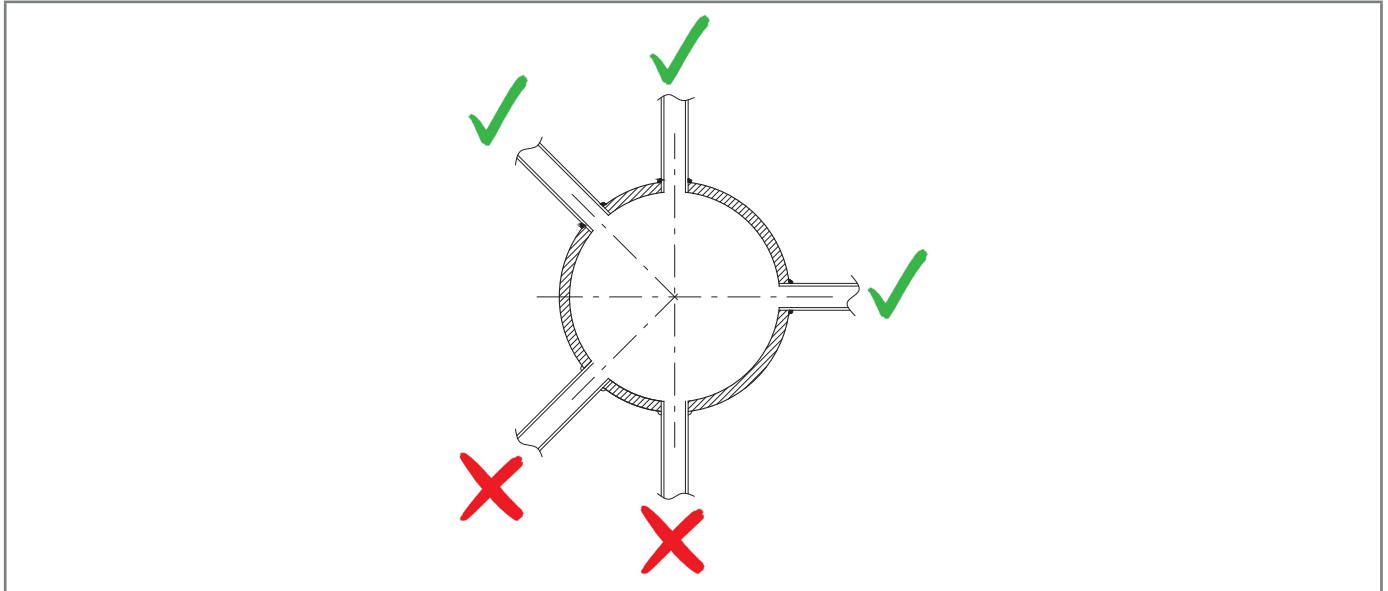

Fig. 6.15. Welded pipe connections

If there is a multiple sensing line, connect the equipment connections as shown below:

- 1 and 2 to the discharge outlet of the regulator control head and of the regulator in monitor function (when present);
- 3 and 4 free sensing lines;
- 5 and 6 to the sensing lines of the slam-shut valve (when present).

**! NOTICE!**

**If there is a multiple sensing line, it is not recommended to place shut-off valves on sensing lines. In any case, follow the regulations in force in the place of installation and use of the equipment.**

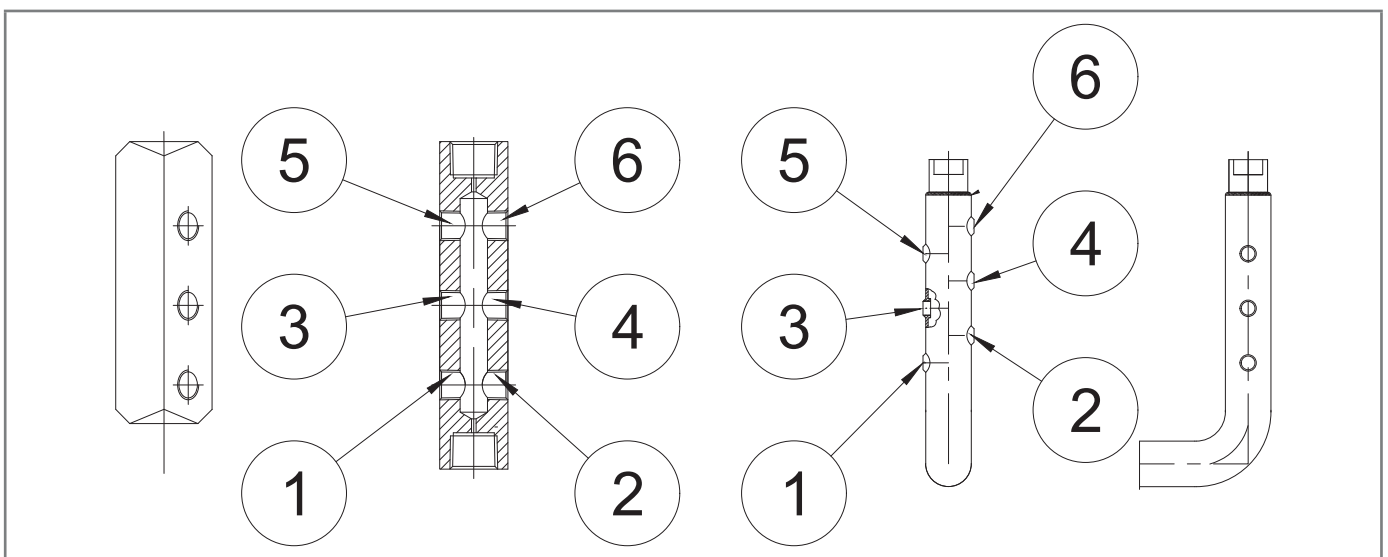

Fig. 6.16. Equipment connections

## **6.6 - POST-INSTALLATION AND PRE-COMMISSIONING CHECKS**

When the equipment is operating, make sure that all connections are:

- properly secured/tightened to prevent any leakage during commissioning;
- connected correctly.











## 7 - COMMISSIONING/MAINTENANCE EQUIPMENT





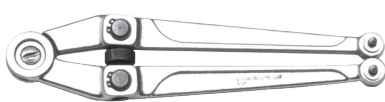



### 7.1 - LIST OF EQUIPMENT

Use of commissioning/maintenance equipment	
<b>Operator qualification</b>	<ul style="list-style-type: none"> <li>• Mechanical maintenance technician;</li> <li>• Electrical maintenance technician;</li> <li>• Installer;</li> <li>• Name of the user.</li> </ul>
<b>PPE required</b>	<div style="display: flex; align-items: center;">  </div> <div style="background-color: #f4a460; padding: 5px; margin-top: 5px;"> <p><b>⚠ WARNING!</b></p> </div> <p>The PPE listed in this table is related to the risk associated with the equipment. For the PPE required to protect against risks associated with the workplace, installation or operating conditions, please refer to:</p> <ul style="list-style-type: none"> <li>• the regulations in force in the country of installation;</li> <li>• any information provided by the Safety Manager at the installation facility.</li> </ul>

Tab. 7.43

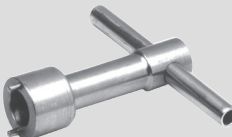
The types of equipment required to commission and service the equipment are described in “Tab. 7.44”:

Ref.	Equipment type	Image
<b>A</b>	Combination wrench	
<b>B</b>	Adjustable wrench	
<b>C</b>	Roller compass spanner	
<b>D</b>	Double ended bi-hex tubular socket wrench	
<b>E</b>	Bent male hex key	
<b>F</b>	Male T-handle hex wrench	

Ref.	Equipment type	Image
<b>G</b>	T-handle hex socket wrench	
<b>H</b>	Phillips screwdriver	
<b>I</b>	Slotted screwdriver	
<b>L</b>	O-ring extraction tool	
<b>M</b>	Circlip pliers	
<b>N</b>	Fiorentini special key	
<b>O</b>	Fiorentini special key	
<b>P</b>	Fiorentini special tool	
<b>Q</b>	Torx key	

Tab. 7.44

## 7.2 - EQUIPMENT NEEDED FOR THE DIFFERENT CONFIGURATIONS

Each table is distinguished by:

Term	Description
<b>K./Wr.</b>	Key, with reference to the equipment indicated in "Tab. 7.44".
<b>Code</b>	Code, referring to the equipment.
<b>DN</b>	Indicates the Nominal Diameter of the reference configuration.
<b>L.</b>	Length, referred to the equipment.
<b>Ref.</b>	Reference to the equipment.
<b>Type</b>	Type (size) or code of the equipment.

Tab. 7.45

### DIVAL 700 | REGULATOR WITH IN LINE MONITOR FUNCTION

Equipment		Size [inches]   DN [mm]		
Ref.	Type	1"   25	1" ½   40	2"   50
<b>A</b>	K./Wr.	10 - 12 - 13 - 17 - 22 - 24		
<b>D</b>	K./Wr.	24 - 26 - 27 - 36 - 46		
<b>E</b>	K./Wr.	19		
<b>F</b>	K./Wr.	3 - 4 - 5 - 6 - 8		
<b>G</b>	K./Wr.	7 - 8 - 10		

Tab. 7.46

### DIVAL 700 + LA

Equipment		Size [inches]   DN [mm]		
Ref.	Type	1"   25	1" ½   40	2"   50
<b>A</b>	K./Wr.	10 - 12 - 13 - 17 - 22 - 24		
<b>D</b>	K./Wr.	24 - 26 - 27 - 36 - 46		
<b>E</b>	K./Wr.	19		
<b>F</b>	K./Wr.	3 - 4 - 5 - 6 - 8		
<b>G</b>	K./Wr.	7 - 8 - 10		
<b>Q</b>	Type	T 20		

Tab. 7.47



## 8 - COMMISSIONING

### 8.1 - GENERAL WARNINGS

#### 8.1.1 - SAFETY REQUIREMENTS FOR COMMISSIONING

##### HAZARD!

During commissioning the risks associated with any discharges to the atmosphere of flammable or noxious gases must be evaluated.

##### HAZARD!

In case of installation on distribution networks for natural gas, consider the risk associated with explosive mixtures (gas/air) being formed inside the piping, if the line is not subjected to inerting.

##### WARNING!

During commissioning, any unauthorised personnel must keep away.  
The no entry area has to be marked with signs and/or boundaries.

##### NOTICE!

Commissioning has to be carried out by authorised and qualified personnel.

The equipment and accessories (regulator with in-line monitor function, LA incorporated slam-shut valve) are supplied already calibrated.



##### NOTICE!

It is possible that for various reasons (e.g. vibrations during transport) the calibration of the equipment's accessories may vary, although within the values indicated on the identification plates.

Before commissioning the equipment, it is necessary to check that:

- all shut-off valves (inlet, outlet, any bypass) are closed;
- the gas is at a temperature within the limits specified on the data plate.

#### Commissioning

<b>Operator qualification</b>	<ul style="list-style-type: none"> <li>• Installer;</li> <li>• Qualified technician.</li> </ul>
<b>PPE required</b>	<div style="text-align: center;">  </div> <div style="background-color: #f96; padding: 5px; margin-top: 5px;">  <b>WARNING!</b> </div> <p>The PPE listed in this table is related to the risk associated with the equipment. For the PPE required to protect against risks associated with the workplace, installation or operating conditions, please refer to:</p> <ul style="list-style-type: none"> <li>• the regulations in force in the country of installation;</li> <li>• any information provided by the Safety Manager at the installation facility.</li> </ul>
<b>Equipment required</b>	Please refer to the chapter "7 - Commissioning/maintenance equipment".

Tab. 8.48

## 8.2 - PRELIMINARY PROCEDURES FOR COMMISSIONING

### HAZARD!

Before commissioning the equipment, it must be ensured that any source of explosion has been eliminated if there is such a danger.

### WARNING!

Before commissioning, you need to make sure that the characteristics of the equipment are suitable for the conditions of use.

### ATTENTION!

To protect the equipment from damage, never:

- pressurise the equipment through a valve located downstream of it;
- depressurise the equipment through a valve located upstream of it.

Commissioning can be carried out using two different procedures:

### Commissioning types

<b>Injection of an inert fluid</b>	Pressurising the equipment by injecting an inert fluid (e.g. nitrogen) to avoid potentially explosive mixtures for services with combustible gases. <div style="background-color: #f4a460; padding: 5px;"> <b>WARNING!</b></div> <b>During pressurisation, always check that the equipment has no leaks.</b>
<b>Direct injection</b>	Direct injection of gas into pipes, keeping the gas velocity in the pipes as low as possible (maximum permitted value of 5 m/s).

Tab. 8.49

### 8.3 - PROPER COMMISSIONING CHECK

Completely sprinkle the equipment with a foaming solution (or equivalent control system) in order to check the tightness of the external surfaces of the regulator and the connections made during the installation.

### 8.4 - CALIBRATION OF EQUIPMENT AND ACCESSORIES INSTALLED

 **NOTICE!**

To properly calibrate the equipment and accessories present, refer to the accuracy class indicated on the nameplates (see section “2.8 - Applied rating plates”).

## 8.5 - REGULATOR COMMISSIONING PROCEDURE

In the application consisting of two pressure adjusting lines, it is advisable to commission one line at a time, starting with the line with the lowest set point.

The set point value is mentioned on the test certificate enclosed with each piece of equipment.

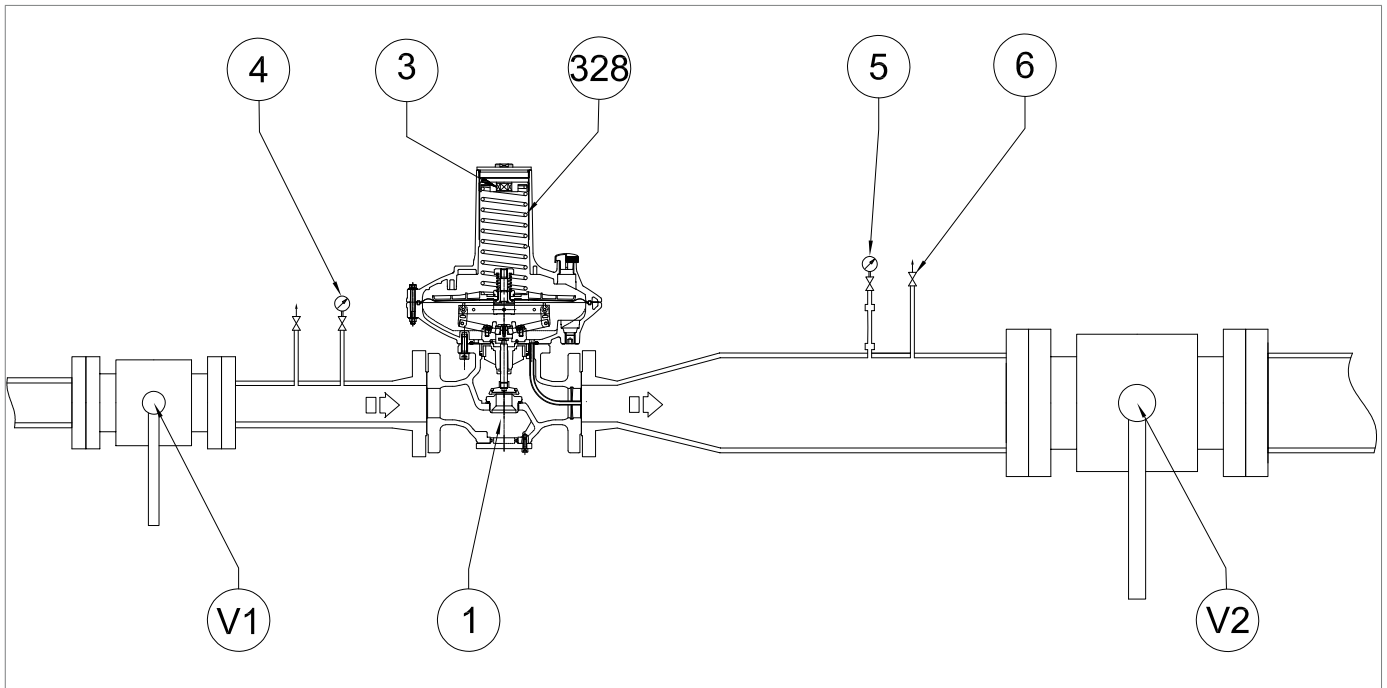

Fig. 8.17. Commissioning the DIVAL 700 regulator



Step	Action
1	Partially open the bleed cock (6).
2	<p>Partially open the upstream shut-off valve (V1), checking that the downstream pressure (Pd) indicated on the downstream pressure gauge (5) does not exceed the required calibration value by over 50%.</p> <p><b>! NOTICE!</b></p> <p><b>In the first line pressurisation phase, the downstream pressure (Pd) indicated on the downstream pressure gauge (5) could exceed that required calibration value, depending on the response time of the regulator.</b></p> <p><b>! NOTICE!</b></p> <p><b>With regulators with calibration pressure up to 80 mbar, the response time is longer than that of regulators with calibration pressure above 80 mbar.</b></p>
3	When the regulator is put into service, the downstream pressure (Pd) indicated on the downstream pressure gauge (5) will be equal to the calibration value of the regulator.
4	<p><b>a - FOR INITIAL COMMISSIONING OF THE REGULATION LINE</b></p> <p>If the pressure downstream (Pd) is not at the required calibration value, proceed as follows:</p> <ul style="list-style-type: none"> <li>• downstream pressure value (Pd) lower than required calibration value: load the setting spring by turning the adjustment ring nut clockwise (3)</li> <li>• downstream pressure value (Pd) higher than required calibration value: load the setting spring by turning the adjustment ring nut anti-clockwise (3)</li> </ul> <p><b>b - AFTER MAINTENANCE OF THE REGULATION LINE</b></p> <ul style="list-style-type: none"> <li>• load the setting spring (328) and increase the pressure value of the main regulator (1) by turning the adjustment ring nut clockwise (3)</li> </ul>
5	Check the downstream pressure (Pd) referring to the downstream pressure gauge (5).
6	Close the bleed cock (6).
7	<p>Check that the downstream pressure (Pd), after an increment phase, does not exceed the closing pressure value (refer to the SG value displayed on the plate, see par. "2.8 - Applied rating plates").</p> <p><b>! NOTICE!</b></p> <p><b>If the pressure in the pipe section between the regulator and the downstream shut-off valve (V2) exceeds the closing pressure value, consult chapter "10 - Troubleshooting" to clear the causes of the malfunctions.</b></p>
8	<p>Check the tightness of all the fittings between the shut-off valves (V1, V2).</p> <p><b>! NOTICE!</b></p> <p><b>Check for sealing with a foaming substance.</b></p>
9	In case of external leaks, eliminate the leak points and repeat the procedure from step 7.
10	<p>Open downstream shut-off valve (V2) very slowly until the pipeline fills completely.</p> <p><b>! NOTICE!</b></p> <p><b>If the pressure of the downstream pipeline is lower than the calibration pressure, partially open the downstream shut-off valve (V2) so as to not to exceed the maximum flow rate value of the installation.</b></p>

Tab. 8.50

**8.6 - COMMISSIONING PROCEDURE OF REGULATION LINE: DIVAL 700 REGULATOR + DIVAL 700 REGULATOR WITH IN LINE MONITOR FUNCTION**

**NOTICE!**

**VALID FOR REGULATORS WITH DOWNSTREAM PRESSURE UP TO 80mbar**

**The setting spring (328.1) of the main regulator (1) must allow you to obtain the downstream pressure value (Pd) 10-20% higher than the calibration pressure value of the regulator with in-line monitor function (2).**

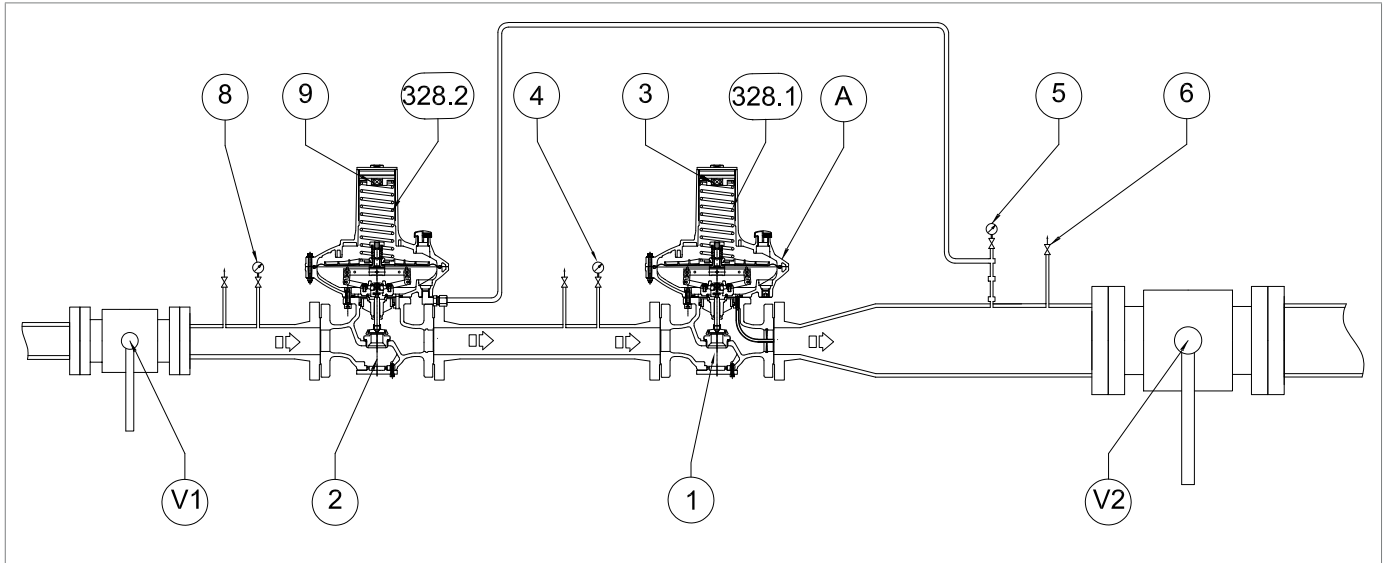
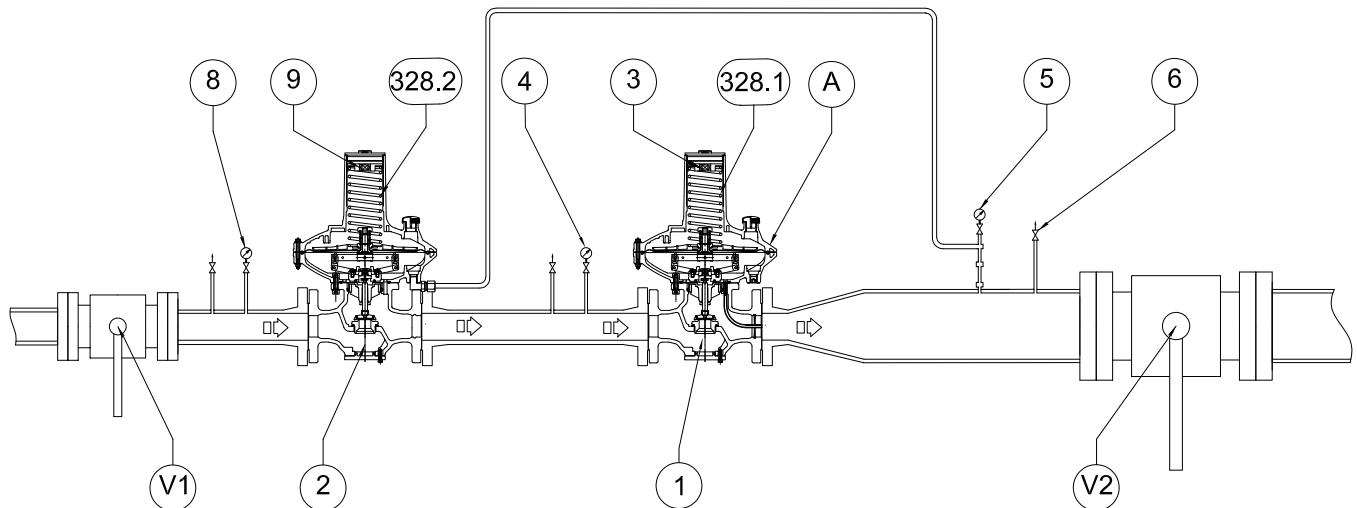

Fig. 8.18. Commissioning of DIVAL 700 regulator + regulator with in-line monitor function

Step	Action
1	Partially open the bleed cock (6).
2	<p>Partially open the upstream shut-off valve (V1), checking that the downstream pressure (Pd) indicated on the downstream pressure gauge (5) does not exceed the required calibration value by over 50%.</p> <p><b>! NOTICE!</b></p> <p><b>In the first line pressurisation phase, the downstream pressure (Pd) indicated on the downstream pressure gauge (5) could exceed that required calibration value, depending on the response time of the main regulator (1).</b></p> <p><b>! NOTICE!</b></p> <p><b>With regulators with calibration pressure up to 80 mbar, the response time is longer than that of regulators with calibration pressure above 80 mbar.</b></p>
3	When the main regulator (1) is put into service, the downstream pressure (Pd) indicated on the downstream pressure gauge (5) will be equal to the calibration value of the main regulator (1).
4	<p>Check that the regulator with in-line monitor function (2) is fully open (100%).</p> <p><b>! NOTICE!</b></p> <p><b>The regulator with monitor function (2) is fully open, when the pressure indicated on the intermediate pressure gauge (4) is the same as the upstream pressure gauge (8).</b></p>
5	Open the upstream shut-off valve (V1) completely.
6	<p>Increase the downstream pressure value (Pd) beyond the calibration pressure of the regulator with monitor function (2), by turning the adjustment ring nut (3) of the main regulator (1) clockwise.</p> <p><b>! NOTICE!</b></p> <p><b>If the setting spring of the main regulator (1) does not reach a sufficient pressure to trip the regulator with in-line monitor function (2), pressurise the chamber (A) by using an external source (see par. "8.6.1 - Pressurising with external source").</b></p> <p><b>! NOTICE!</b></p> <p><b>The value of the pressure introduced by the external source can be up to 50% more than the calibration value of the regulator with in-line monitor function (2).</b></p>
7	Check that the regulator with in-line monitor function (2) is running, checking that the pressure indicated on the intermediate pressure gauge (4) is comparable to the calibration value of the regulator with in-line monitor function (2).
8	<p><b>a - FOR INITIAL COMMISSIONING OF THE REGULATION LINE</b></p> <p>If the downstream pressure (Pd) is not at the required calibration value for the regulator with in-line monitor function (2), proceed as follows:</p> <ul style="list-style-type: none"> <li>• downstream pressure value (Pd) lower than required calibration value: load the setting spring by turning the adjustment ring nut clockwise (9)</li> <li>• downstream pressure value (Pd) higher than required calibration value: load the setting spring by turning the adjustment ring nut anti-clockwise (9)</li> </ul> <p><b>b - AFTER MAINTENANCE OF THE REGULATION LINE</b></p> <ul style="list-style-type: none"> <li>• load the setting spring (328.2) and increase the pressure value of the regulator with monitor function (2) by turning the adjustment ring nut clockwise (9)</li> </ul>
9	<p>Check the calibration value of the regulator with in-line monitor function (2), referring to the downstream pressure gauge (5).</p> <p><b>! NOTICE!</b></p> <p><b>If the calibration pressure is not as pre-established, repeat steps 8a (first commissioning) or 8b (after maintenance).</b></p>



Commissioning of DIVAL 700 regulator + regulator with in-line monitor function

Step	Action
10	Slowly close the bleed cock (6).
11	<p>Check that the downstream pressure, after an increment phase, does not exceed the closing pressure value of the regulator with in-line monitor function (2) (refer to the SG value displayed on the plate, see par. “2.8 - Applied rating plates”).</p> <div style="border: 1px solid blue; padding: 5px;"> <p><b>! NOTICE!</b></p> <ul style="list-style-type: none"> <li>• <b>If the downstream pressure exceeds the closing pressure value, refer to chapter “10 - Troubleshooting” to clear the causes of the malfunctions.</b></li> <li>• <b>Check the pressure referring to the downstream pressure gauge (5).</b></li> </ul> </div>
12	Partially open the bleed cock (6).
13	Discharge the regulation spring of the main regulator (1) or disconnect the external pressure source from the chamber (A).
14	<p>Check that the regulator with in-line monitor function (2) is fully open (100%).</p> <div style="border: 1px solid blue; padding: 5px;"> <p><b>! NOTICE!</b></p> <p><b>The regulator with in-line monitor function (2) is fully open, when the pressure indicated on the intermediate pressure gauge (4) is the same as the upstream pressure gauge (8).</b></p> </div>
15	Check that the calibration pressure of the main regulator (1) is as pre-established by referring to the pressure value indicated on the downstream pressure gauge (5).
16	<p><b>a - FOR INITIAL COMMISSIONING OF THE REGULATION LINE</b></p> <p>If the pressure downstream (Pd) is not at the required calibration value, proceed as follows:</p> <ul style="list-style-type: none"> <li>• downstream pressure value (Pd) lower than required calibration value: load the setting spring by turning the adjustment ring nut clockwise (3)</li> <li>• downstream pressure value (Pd) higher than required calibration value: load the setting spring by turning the adjustment ring nut anti-clockwise (3)</li> </ul> <p><b>b - AFTER MAINTENANCE OF THE REGULATION LINE</b></p> <ul style="list-style-type: none"> <li>• load the setting spring (328.1) and increase the pressure value of the main regulator (1) by turning the adjustment ring nut clockwise (3)</li> </ul>
17	Slowly close the bleed cock (6).

Step	Action
18	<p>Check that the downstream pressure, after an increment phase, does not exceed the closing pressure value of the main regulator (1) (refer to the SG value displayed on the plate, see par. "2.8 - Applied rating plates").</p> <div style="border: 1px solid black; padding: 5px;"> <p><b>! NOTICE!</b></p> <ul style="list-style-type: none"> <li>• <b>If the downstream pressure exceeds the closing pressure value, refer to chapter "10 - Troubleshooting" to clear the causes of the malfunctions.</b></li> <li>• <b>Check the pressure referring to the downstream pressure gauge (5).</b></li> </ul> </div>
19	Using a foaming agent, check all the joints between shut-off valves (V1, V2) for proper sealing.
20	In case of external leaks, eliminate the leak points and repeat the procedure from step 1.
21	<p>Slowly open the downstream shut-off valve V2 until the piping has been completely filled.</p> <div style="border: 1px solid black; padding: 5px;"> <p><b>! NOTICE!</b></p> <ul style="list-style-type: none"> <li>• <b>If the pressure of the downstream pipeline is lower than the calibration pressure, partially open the downstream shut-off valve (V2) so as to not to exceed the maximum flow rate value of the installation.</b></li> <li>• <b>Check the pressure referring to the downstream pressure gauge (5).</b></li> </ul> </div>

Tab. 8.51

### 8.6.1 - PRESSURISING WITH EXTERNAL SOURCE

If the setting spring of the main regulator (1) does not reach a sufficient pressure to put into service the regulator with in-line monitor function (2), you may pressurise the chamber (A) of the control head of the main regulator (1) by using an external source.

Pressurisation can be done:

- with external lines;
- manually.

The introduced pressure is controlled by using pressure gauges or transducers.

To correctly discharge the introduced pressure, make sure there is an additional bleed cock (18).

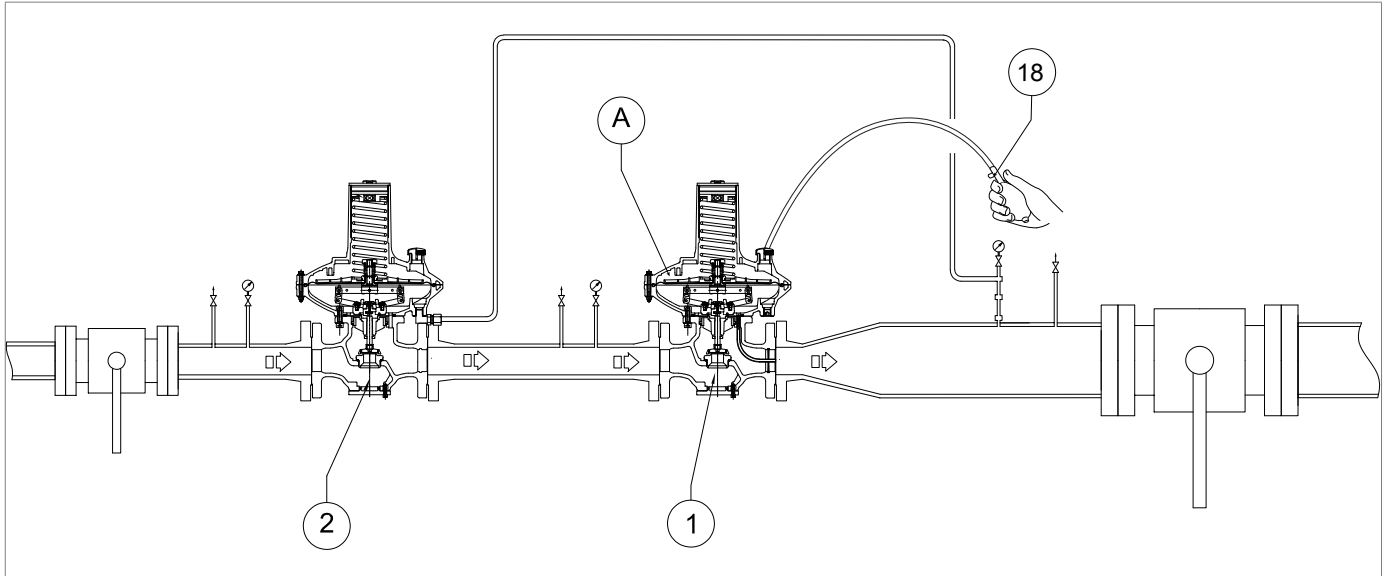

Fig. 8.19. Pressurising with external source (hand pump)



## 8.7 - COMMISSIONING PROCEDURE OF DIVAL 700 REGULATOR WITH LA SLAM-SHUT VALVE

### 8.7.1 - INTERNAL TIGHTNESS CHECK OF LA SLAM-SHUT VALVE

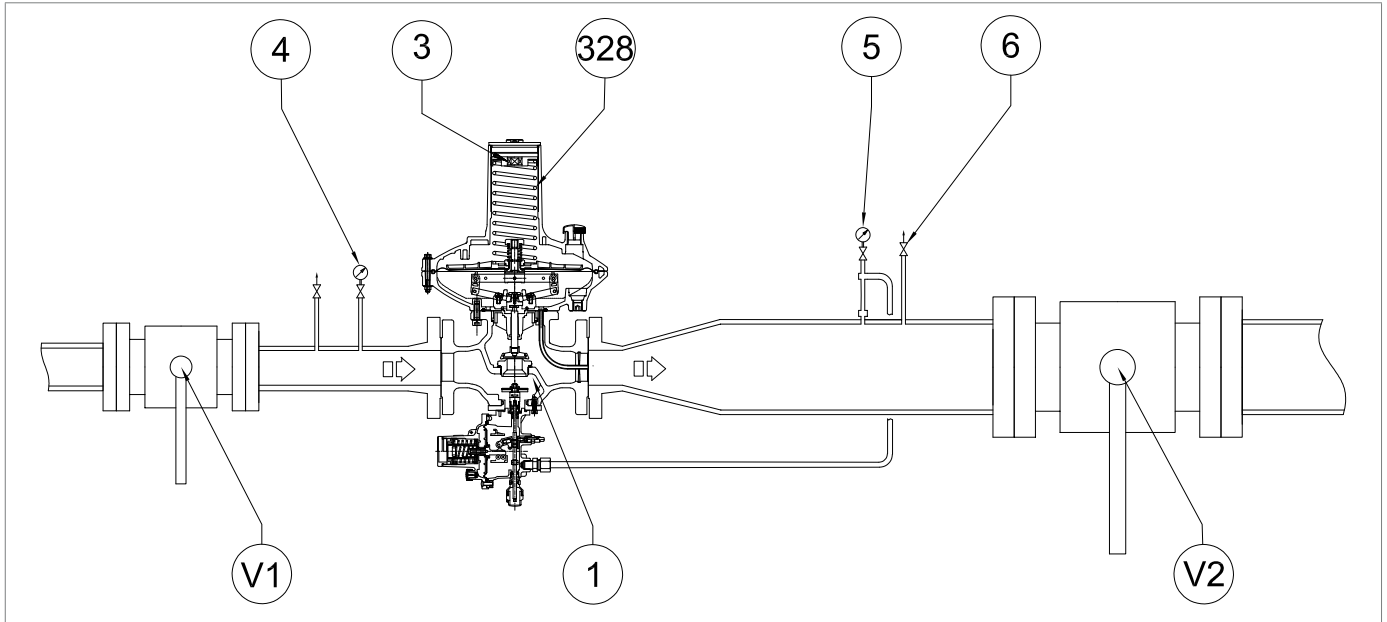

Fig. 8.20. Commissioning of the regulator DIVAL 700 with LA slam-shut valve

Step	Action
1	Check that the slam-shut valve is in the shut-off position.
2	Open the bleed cock (6) to fully discharge the downstream section.
3	Slowly open the upstream shut-off valve (V1).
4	Check the internal tightness of the slam-shut valve by means of the bleed cock (6). <div style="border: 1px solid black; padding: 5px; margin-top: 5px;"> <p><b>! NOTICE!</b></p> <ul style="list-style-type: none"> <li>• Check the seal with a foaming substance;</li> <li>• In case of leaks, please refer to the chapter “10 - Troubleshooting” to clear the causes of malfunctions.</li> </ul> </div>

Tab. 8.52



## 8.7.2 - COMMISSIONING OF THE DIVAL 700 REGULATOR WITH LA SLAM-SHUT VALVE

For the following procedure, please refer to Fig. 8.20 at “8.7.1 - Internal tightness check of LA slam-shut valve”:

Step	Action
1	Make sure that the bleed cock (6) is partially open.
2	<p>Check that the LA slam-shut valve is in the shut-off position.</p> <p><b>! NOTICE!</b>  <b>If the LA slam-shut valve is in the open position, close it using the manual button (fig. 8.20, ref. 10).</b></p>
3	Partially open the upstream shut-off valve (V1), checking the pressure indicated by the upstream pressure gauge (4).
4	<p>Perform the internal tightness check of the LA slam-shut valve, referring to chapter “8.7.1 - Internal tightness check of LA slam-shut valve”.</p> <p><b>! NOTICE!</b>  <b>In case of leaks, please refer to the chapter “10 - Troubleshooting” to clear the causes of malfunctions.</b></p>
5	Slowly pressurise the control line, acting on the knob of the LA slam-shut valve (refer to the "Operation" section at 4.5.4.1), checking that the downstream pressure (Pd) indicated by the downstream pressure gauge (5) does not exceed the required setting value by more than 50%.
6	<p>When the regulator is put into service, the pressure on the downstream pressure gauge (5) will be equal to the calibration value of the main regulator.</p> <p><b>! NOTICE!</b>  <b>In the first line pressurisation phase, the pressure on the downstream pressure gauge (5) could exceed the required calibration value, depending on the response time of the regulator.</b></p>
7	Open the upstream shut-off valve (V1) completely.
8	Check calibrations of the pressure switch of the LA slam-shut valve by referring to paragraph “8.7.3 - Procedure for calibrating the pressure switch for the LA incorporated slam-shut valve”.
9	<p><b>a - FOR INITIAL COMMISSIONING OF THE REGULATION LINE</b>            If the pressure downstream (Pd) is not at the required calibration value, proceed as follows:</p> <ul style="list-style-type: none"> <li>downstream pressure value (Pd) lower than required calibration value: load the setting spring by turning the adjustment ring nut clockwise (3)</li> <li>downstream pressure value (Pd) higher than required calibration value: load the setting spring by turning the adjustment ring nut anti-clockwise (3)</li> </ul> <p><b>b - AFTER MAINTENANCE OF THE REGULATION LINE</b></p> <ul style="list-style-type: none"> <li>load the setting spring (328) and increase the pressure value of the regulator (1) by turning the adjustment ring nut clockwise (3)</li> </ul>
10	Check the downstream pressure (Pd) referring to the downstream pressure gauge (5).
11	Close the bleed cock (6).

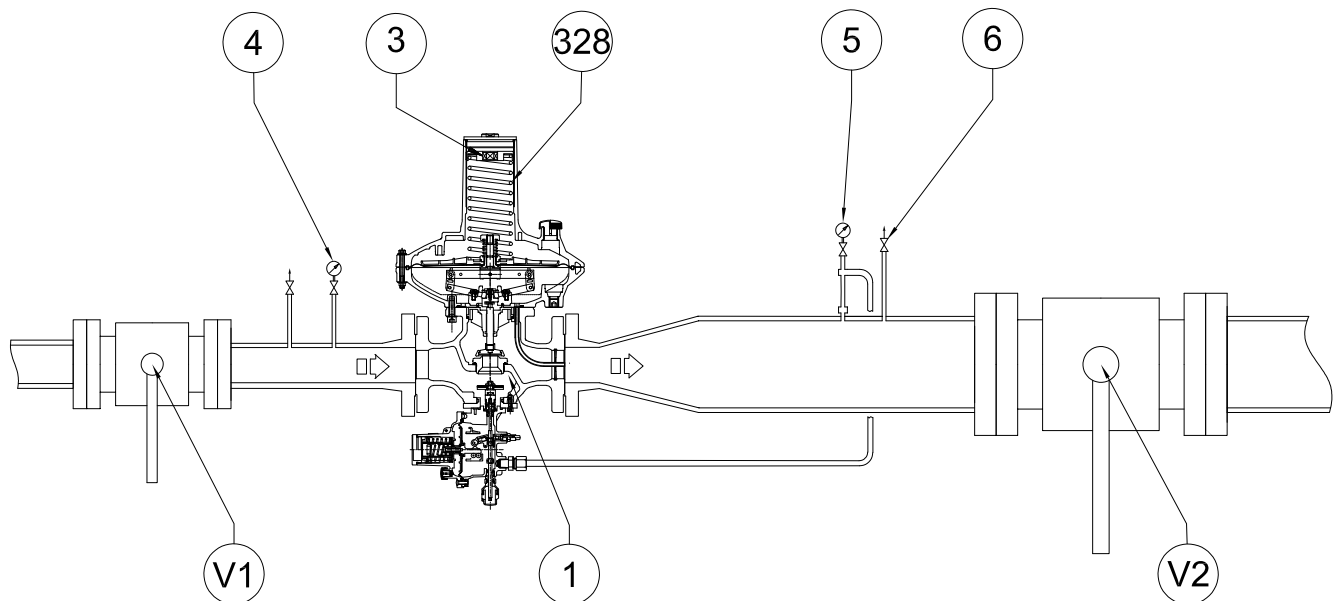

Commissioning of the DIVAL 700 regulator with LA slam-shut valve

Step	Action
12	<p>Check that the downstream pressure (<math>P_d</math>), after an increment phase, does not exceed the closing pressure value (refer to the SG value displayed on the plate, see par."2.8 - Applied rating plates").</p> <p><b>! NOTICE!</b></p> <p><b>If the pressure in the pipe section between the regulator and the downstream shut-off valve (V2) exceeds the closing pressure value, consult chapter "10 - Troubleshooting" to clear the causes of the malfunctions.</b></p>
13	<p>Check the tightness of all the fittings between the shut-off valves (V1, V2).</p> <p><b>! NOTICE!</b></p> <p><b>Check for sealing with a foaming substance.</b></p>
14	<p>If external leaks are noticed, eliminate the leak points and repeat the procedure from step 7.</p>
15	<p>Open downstream shut-off valve (V2) very slowly until the pipeline fills completely.</p> <p><b>! NOTICE!</b></p> <p><b>If the pressure of the downstream pipeline is lower than the calibration pressure, partially open the downstream shut-off valve (V2) so as to not to exceed the maximum flow rate value of the installation.</b></p>

Tab. 8.53



**8.7.3 - PROCEDURE FOR CALIBRATING THE PRESSURE SWITCH FOR THE LA INCORPORATED SLAM-SHUT VALVE**

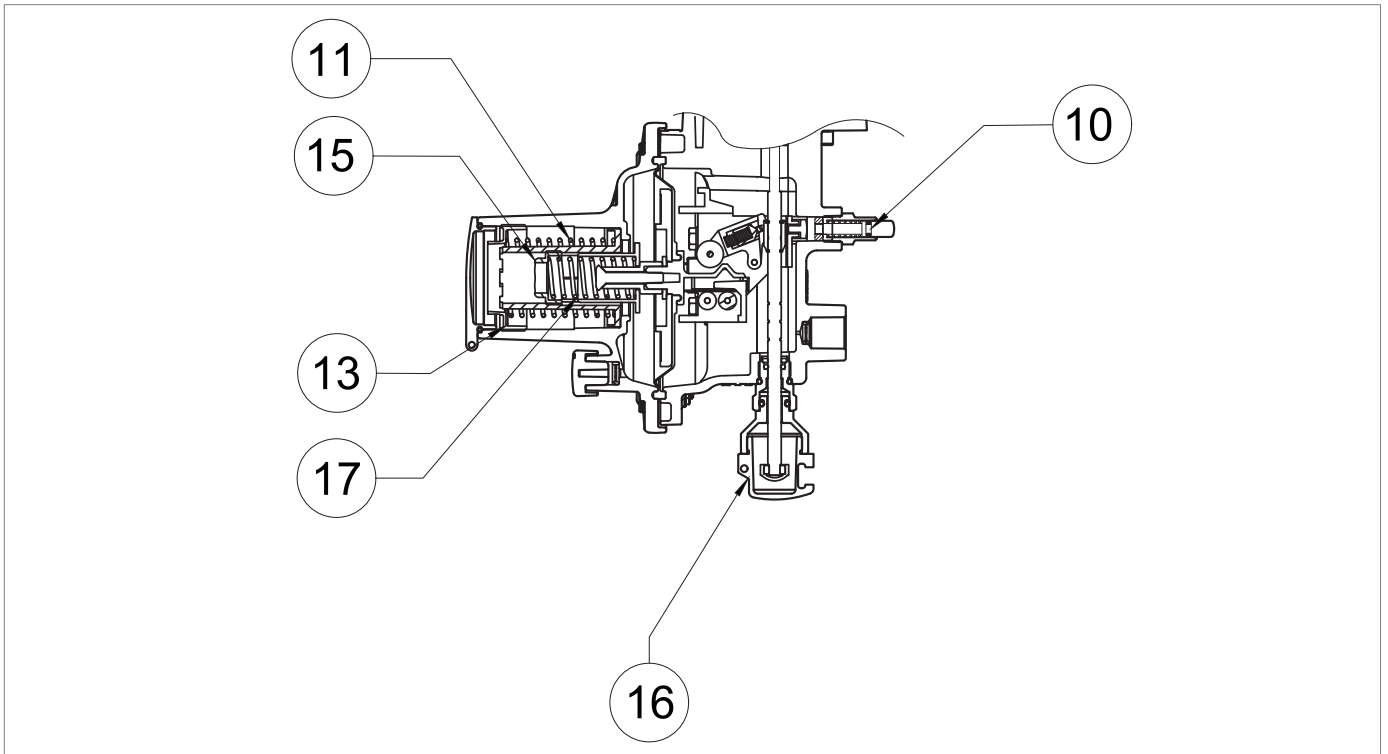

Fig. 8.21. Calibration of pressure switch for LA slam-shut valve

## SPRING CALIBRATION FOR MAXIMUM PRESSURE TRIP

Step	Action
1	<p>Increase the downstream pressure to the tripping value of the slam-shut valve, connecting an external pressure source to the bleed cock (fig. 8.16, ref. 6) placed on the downstream pipe, making sure to open an additional bleed cock (fig. 8.21, ref. 18).</p> <div style="border: 1px solid black; padding: 5px;"> <p><b>! NOTICE!</b></p> <p><b>Check the pressure referring to the downstream pressure gauge (fig. 8.16, ref. 5).</b></p> <p><b>If the slam-shut valve:</b></p> <ul style="list-style-type: none"> <li>• <b>trips before the expected pressure value: screw in (clockwise) the adjustment ring nut (13) so as to further compress the spring (11);</b></li> <li>• <b>does not trip at the expected pressure value: unscrew (anti-clockwise) the adjustment ring nut (13) so as to relieve the spring (11).</b></li> </ul> </div>
2	Decrease the pressure of the downstream section by opening the additional bleed cock (21, ref. 18) to bring it up to the calibration value of the main regulator.
3	Close the additional bleed cock (fig. 8.21, ref. 18).
4	Resetting the slam-shut valve by turning the reset knob (16).
5	Repeat steps 1-2-3-4 at least three times, observing the operating limits indicated on the nameplate.
6	Disconnect the external pressure source from the bleed cock (fig. 8.16, ref. 6).

Tab. 8.54

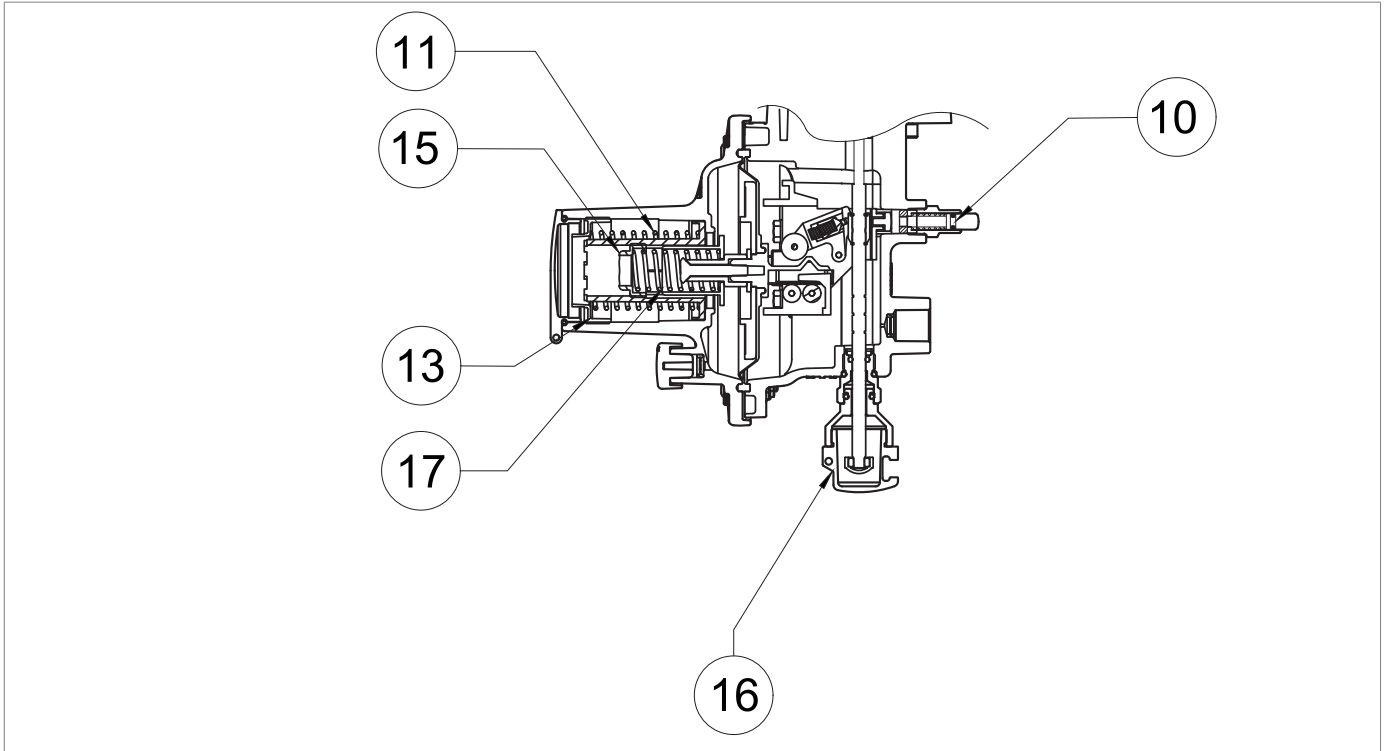

Fig. 8.21. Calibration of pressure switch for LA slam-shut valve

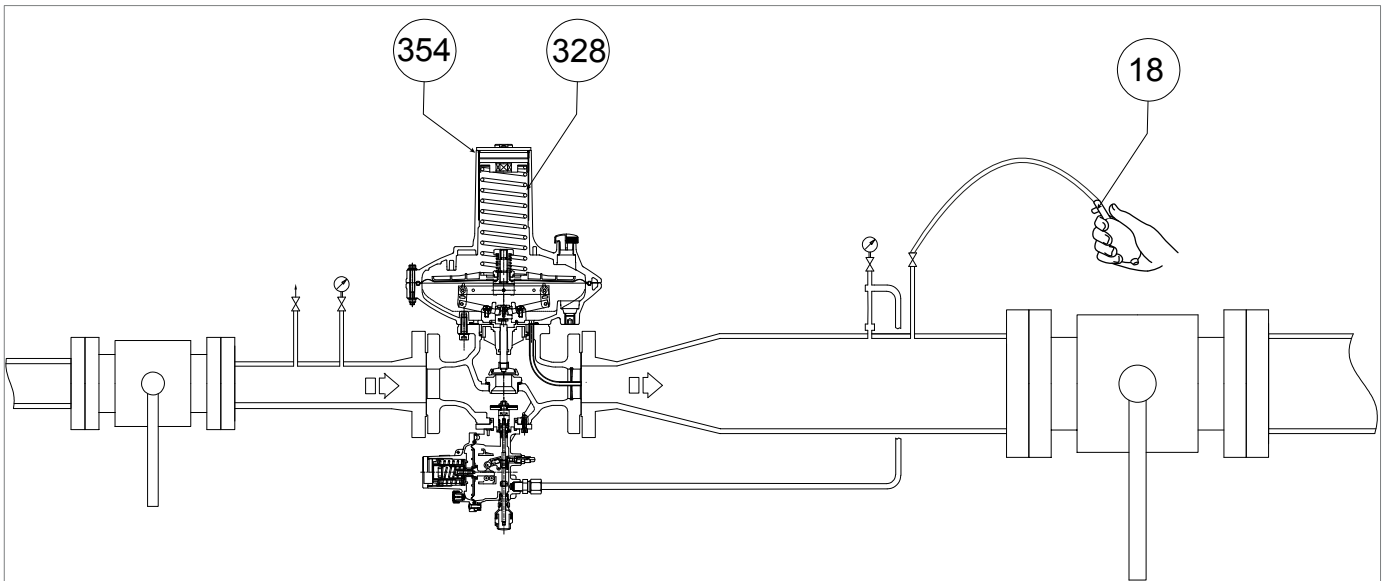

Fig. 8.22. Pressurising with external source for incorporated LA slam-shut valve

## SPRING CALIBRATION FOR MINIMUM PRESSURE TRIP (IF PRESENT)

Step	Action
1	Partially open the bleed cock (fig. 8.16, ref. 6) to the atmosphere and keep it open for the next steps.
2	Turn the adjustment ring nut (fig. 8.16, ref. 3) of the regulator anti-clockwise to decrease the downstream pressure (Pd) to the minimum pressure required for tripping of the slam-shut valve.
3	<p>If necessary, remove the closing cap (fig. 8.22, ref. 354) together with the adjustment ring nut and remove the regulation spring (fig. 8.22, ref. 328).</p> <div style="border: 1px solid blue; padding: 5px;"> <p><b>! NOTICE!</b></p> <p><b>Check the tripping pressure value of the slam-shut valve indicated on the downstream pressure gauge (fig. 8.19, ref. 5).</b></p> </div>
4	<p>If the slam-shut valve:</p> <ul style="list-style-type: none"> <li>trips before the expected pressure value, unscrew (anticlockwise) the adjustment ring nut (fig. 8.20, ref. 15), to relieve the spring (fig. 8.20, ref. 17);</li> <li>does not trip at the expected pressure value, screw in (clockwise) the adjustment ring nut (fig. 8.20, ref. 15) to further compress the spring (fig. 8.20, ref. 17).</li> </ul>
5	<p><b>After having checked that the slam-shut valve trips at the preset value, proceed as follows:</b></p> <ol style="list-style-type: none"> <li>Close the air vent valve (fig. 8.16, ref. 6)</li> <li>Position the regulation spring (fig. 8.21, ref. 328), the closing cap (fig. 8.21, ref. 354), and adjustment ring nut (fig. 8.16, ref. 3)</li> <li>Slowly open the upstream shut-off valve (V1) until the downstream pressure value (Pd) reaches the calibration value of the regulator, referring to the downstream pressure gauge (fig. 8.16, ref. 5)</li> <li>Close the upstream shut-off valve (V1)</li> <li>Slowly and partially open the air vent valve (fig. 8.16, ref. 6) to decrease the downstream pressure referring to the downstream pressure gauge (fig. 8.16, ref. 5) until it reaches the minimum pressure tripping value</li> <li>Check the minimum pressure spring for proper calibration by repeating steps 2-3-4 at least three times</li> <li>Calibrate the main regulator referring to par. "8.5 - Regulator commissioning procedure"</li> </ol>
6	Open the slam-shut valve by acting on the reset knob (fig. 8.20, ref. 16) and keep it open manually.
7	Turn the adjustment ring nut clockwise (fig. 8.16, ref. 3) to increase the downstream pressure to the regulator's setpoint.
8	Set the slam-shut valve by acting on the reset knob (fig. 8.20, ref. 16).
9	Close the bleed cock (fig. 8.16, ref. 6).

Tab. 8.55

## COMMISSIONING THE REGULATOR

**! NOTICE!**

Please refer to "8.5 - Regulator commissioning procedure" of this chapter.

## 8.8 - COMMISSIONING PROCEDURE OF REGULATION LINE: DIVAL 700 REGULATOR + DIVAL 700 REGULATOR WITH IN LINE MONITOR + LA SLAM-SHUT VALVE FUNCTION

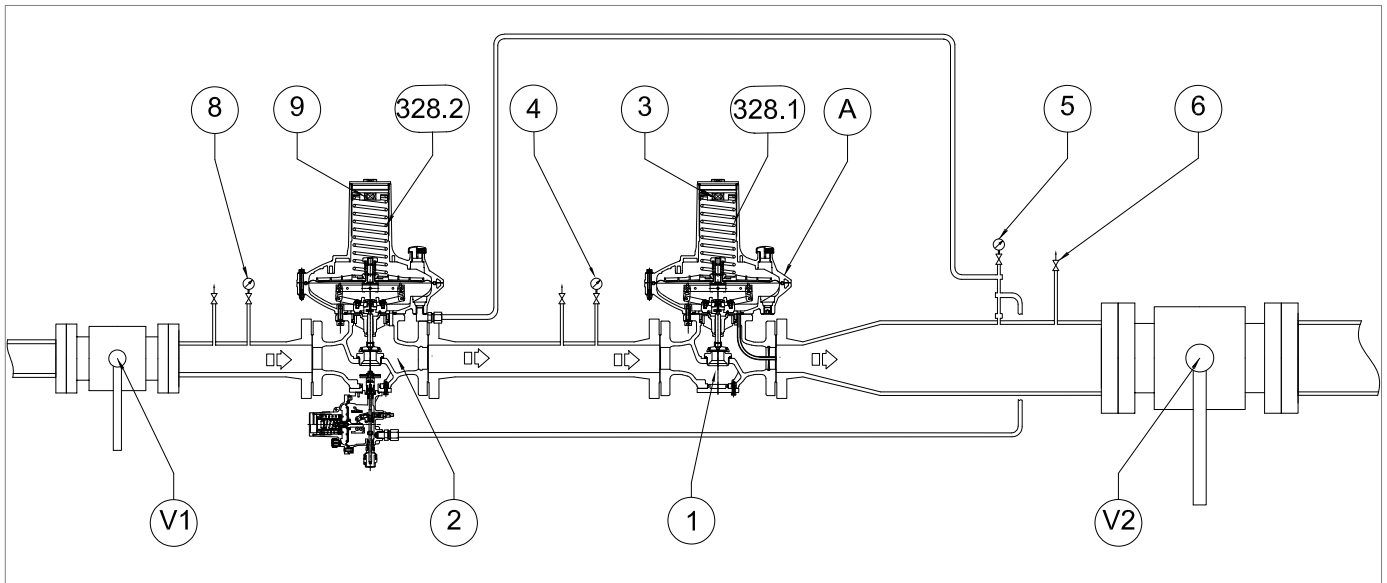





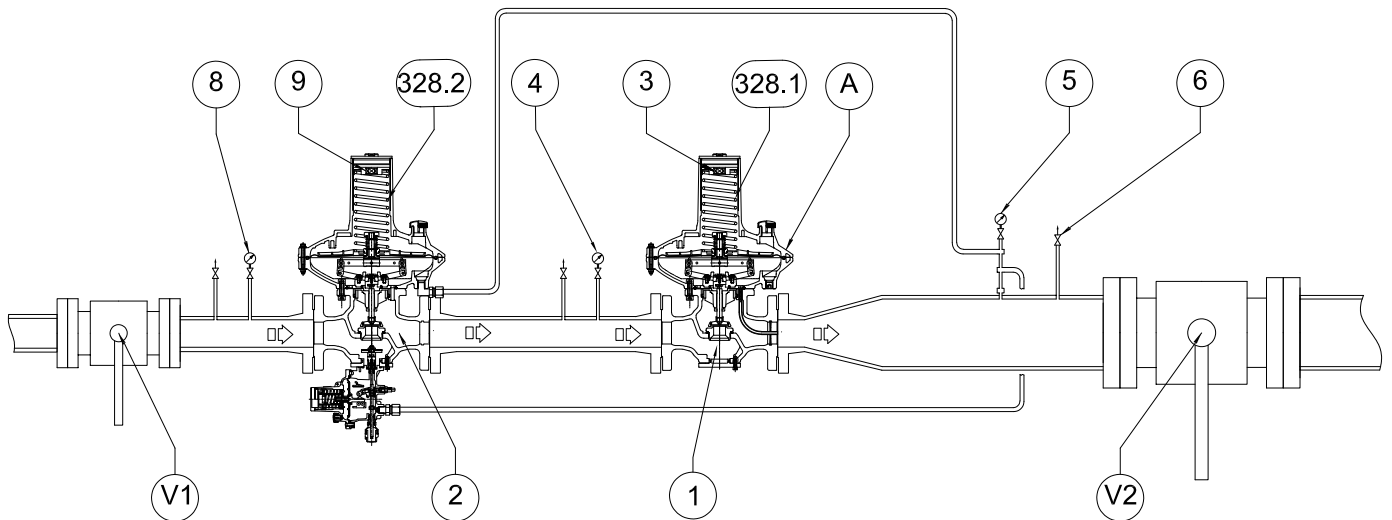

Fig. 8.23. Commissioning of DIVAL 700 regulator + regulator-monitor + LA

Step	Action
1	Make sure that the bleed cock (6) is partially open.
2	Check that the LA slam-shut valve is in the shut-off position. <b>NOTICE!</b> <b>If the LA slam-shut valve is in the open position, close it using the manual button (fig. 8.20, ref. 10).</b>
3	Slowly open the upstream shut-off valve (V1), checking the pressure indicated by the upstream pressure gauge (4).
4	Perform the internal tightness check of the LA slam-shut valve, referring to chapter "8.7.1 - Internal tightness check of LA slam-shut valve". <b>NOTICE!</b> <b>In case of leaks, please refer to the chapter "10 - Troubleshooting" to clear the causes of malfunctions.</b>
5	Make sure that the bleed cock (6) is partially open.
6	Slowly pressurise the control line, acting on the lever of the LA slam-shut valve (refer to the "Operation" section in par. 4.5.4.1), checking that the downstream pressure (Pd) indicated by the downstream pressure gauge (5) does not exceed the required setting value by more than 50%.
7	When the regulator is put into service, the pressure on the downstream pressure gauge (5) will be equal to the calibration value of the main regulator. <b>NOTICE!</b> <b>In the first line pressurisation phase, the pressure on the downstream pressure gauge (5) could exceed the required calibration value, depending on the response time of the regulator.</b>
8	Check calibrations of the pressure switch of the LA slam-shut valve by referring to paragraph "8.7.3 - Procedure for calibrating the pressure switch for the LA incorporated slam-shut valve".



Step	Action
9	 <b>NOTICE!</b> <b>With regulators with calibration pressure up to 80 mbar, the response time is longer than that of regulators with calibration pressure above 80 mbar.</b>
10	When the main regulator (1) is put into service, the downstream pressure (Pd) indicated on the downstream pressure gauge (5) will be equal to the calibration value of the regulator (1).
11	Check that the regulator with in-line monitor function (2) is fully open (100%).  <b>NOTICE!</b> <b>The regulator with monitor function (2) is fully open, when the pressure indicated on the intermediate pressure gauge (4) is the same as the upstream pressure gauge (8).</b>
12	Open the upstream shut-off valve (V1) completely.
13	Increase the downstream pressure value (Pd) beyond the calibration pressure of the regulator with monitor function (2), by turning the adjustment ring nut (3) of the main regulator (1) clockwise.  <b>NOTICE!</b> <b>If the setting spring of the main regulator (1) does not reach a sufficient pressure to trip the regulator with in-line monitor function (2), pressurise the chamber (A) by using an external source (see par. "8.6.1 - Pressurising with external source").</b>  <b>NOTICE!</b> <b>The value of the pressure introduced by the external source can be up to 50% more than the calibration value of the regulator with in-line monitor function (2).</b>
14	Check that the regulator with in-line monitor function (2) is running, checking that the pressure indicated on the intermediate pressure gauge (4) is equal to the calibration value of the regulator with in-line monitor function (2).
15	<b>a - FOR INITIAL COMMISSIONING OF THE REGULATION LINE</b> If the downstream pressure (Pd) is not at the required calibration value for the regulator with in-line monitor function (2), proceed as follows: <ul style="list-style-type: none"> <li>• downstream pressure value (Pd) lower than required calibration value: load the setting spring by turning the adjustment ring nut clockwise (9)</li> <li>• downstream pressure value (Pd) higher than required calibration value: load the setting spring by turning the adjustment ring nut anti-clockwise (9)</li> </ul> <b>b - AFTER MAINTENANCE OF THE REGULATION LINE</b> <ul style="list-style-type: none"> <li>• load the setting spring (328.2) and increase the pressure value of the regulator with in-line monitor function (2) by turning the adjustment ring nut clockwise (9)</li> </ul>
16	Check the calibration value of the regulator with in-line monitor function (2), referring to the downstream pressure gauge (5).  <b>NOTICE!</b> <b>If the calibration pressure is not as pre-established, repeat steps 15a (first commissioning) or 15b (after maintenance).</b>
17	Slowly close the bleed cock (6).



Commissioning of DIVAL 700 regulator + regulator-monitor + LA

Step	Action
18	<p>Check that the downstream pressure, after an increment phase, does not exceed the closing pressure value of the regulator with in-line monitor function (2) (refer to the SG value displayed on the plate, see par. "2.8 - Applied rating plates").</p> <div style="border: 1px solid blue; padding: 5px;"> <p><b>! NOTICE!</b></p> <ul style="list-style-type: none"> <li>• If the downstream pressure exceeds the closing pressure value, refer to chapter "10 - Troubleshooting" to clear the causes of the malfunctions.</li> <li>• Check the pressure referring to the downstream pressure gauge (5).</li> </ul> </div>
19	Partially open the bleed cock (6).
20	Discharge the regulation spring (328.1) of the main regulator (1) or disconnect the external pressure source from the chamber (A) (see par. "8.6.1 - Pressurising with external source").
21	<p>Check that the regulator with in-line monitor function (2) is fully open (100%).</p> <div style="border: 1px solid blue; padding: 5px;"> <p><b>! NOTICE!</b></p> <p><b>The regulator with monitor function (2) is fully open, when the pressure indicated on the intermediate pressure gauge (4) is the same as the upstream pressure gauge (8).</b></p> </div>
22	Check that the calibration pressure of the main regulator (1) is as pre-established by referring to the pressure value indicated on the downstream pressure gauge (5).
23	<p><b>a - FOR INITIAL COMMISSIONING OF THE REGULATION LINE</b></p> <p>If the pressure downstream (Pd) is not at the required calibration value, proceed as follows:</p> <ul style="list-style-type: none"> <li>• downstream pressure value (Pd) lower than required calibration value: load the setting spring by turning the adjustment ring nut clockwise (3)</li> <li>• downstream pressure value (Pd) higher than required calibration value: load the setting spring by turning the adjustment ring nut anti-clockwise (3)</li> </ul> <p><b>b - AFTER MAINTENANCE OF THE REGULATION LINE</b></p> <ul style="list-style-type: none"> <li>• load the setting spring (328.1) and increase the pressure value of the main regulator (1) by turning the adjustment ring nut clockwise (3)</li> </ul>
24	Slowly close the bleed cock (6).

Step	Action
25	<p>Check that the downstream pressure, after an increment phase, does not exceed the closing pressure value of the main regulator (1) (refer to the SG value displayed on the plate, see par. "2.8 - Applied rating plates").</p> <div style="border: 1px solid black; padding: 5px;"> <p><b>! NOTICE!</b></p> <ul style="list-style-type: none"> <li>• <b>If the downstream pressure exceeds the closing pressure value, refer to chapter "10 - Troubleshooting" to clear the causes of the malfunctions.</b></li> <li>• <b>Check the pressure referring to the downstream pressure gauge (5).</b></li> </ul> </div>
26	Using a foaming agent, check all the joints between shut-off valves (V1, V2) for proper sealing.
27	If external leaks are noticed, eliminate the leak points and repeat the procedure from step 10.
28	<p>Slowly open the downstream shut-off valve V2 until the piping has been completely filled.</p> <div style="border: 1px solid black; padding: 5px;"> <p><b>! NOTICE!</b></p> <ul style="list-style-type: none"> <li>• <b>If the pressure of the downstream pipeline is lower than the calibration pressure, partially open the downstream shut-off valve (V2) so as to not to exceed the maximum flow rate value of the installation.</b></li> <li>• <b>Check the pressure referring to the downstream pressure gauge (5).</b></li> </ul> </div>

Tab. 8.56

## COMMISSIONING OF LA SLAM-SHUT VALVE

**! NOTICE!**

Refer to paragraph "8.7.3 - Procedure for calibrating the pressure switch for the LA incorporated slam-shut valve".

**8.9 - DEVICE CALIBRATION**

**8.9.1 - PRESSURE SWITCH CALIBRATION FOR THE LA SLAM-SHUT VALVE**

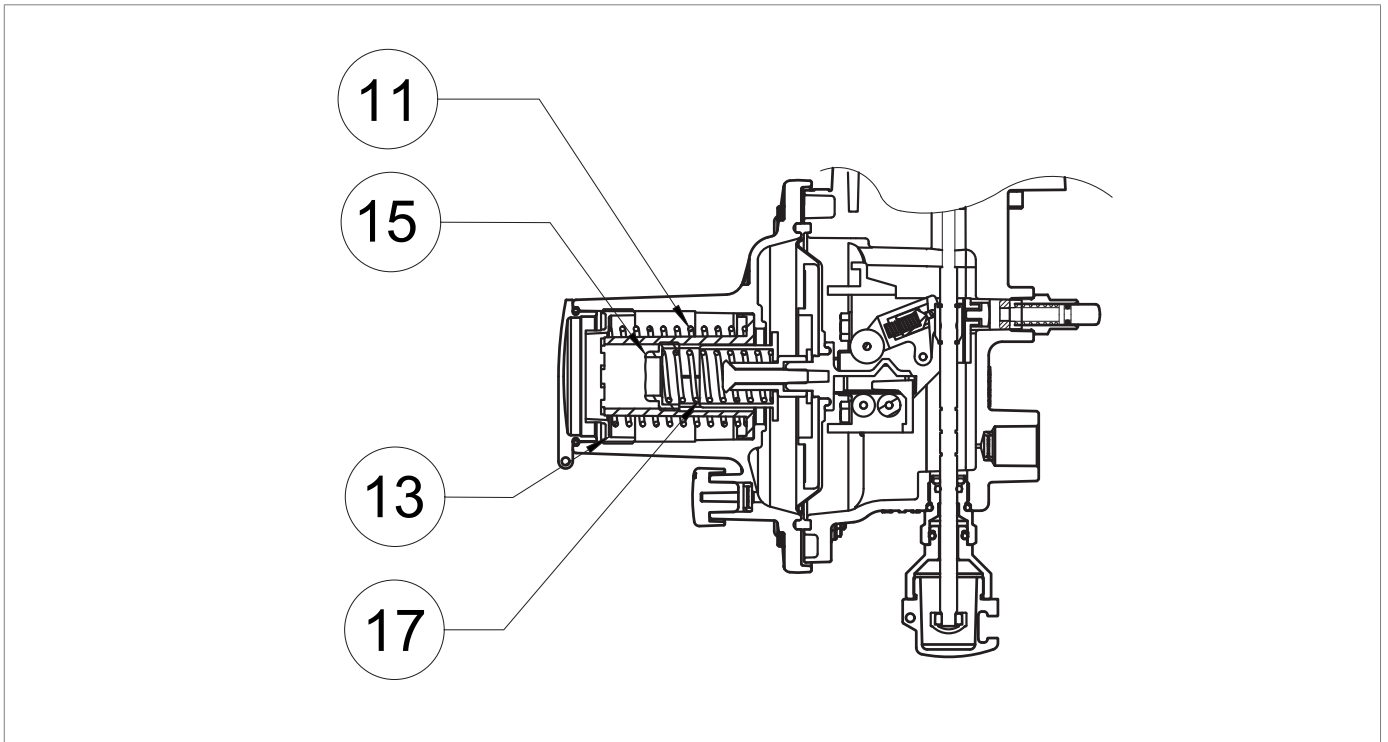

Fig. 8.24. Pressure switch calibration for the LA slam-shut valve

Turn the ring nut (13) for maximum tripping (11):

- anti-clockwise to decrease the slam-shut device tripping pressure;
- clockwise to increase the slam-shut device tripping pressure.

Turn the ring nut (15) for minimum tripping (17):

- anti-clockwise to decrease the slam-shut device tripping pressure;
- clockwise to increase the slam-shut device tripping pressure.

**! NOTICE!**

**For calibration ranges, please refer to chapter “13 - Flow rate tables”.**

## 9 - MAINTENANCE AND FUNCTIONAL CHECKS

### 9.1 - GENERAL WARNINGS

#### HAZARD!

- Maintenance work must be carried out by qualified personnel trained on safety in the workplace and authorised to carry out equipment-related activities.
- Each maintenance operation requires in-depth and specialised knowledge of the equipment, the necessary operations, the associated risks and the correct procedures to operate safely.
- Repair or maintenance work not provided for in this manual may be carried out only if approved by PIETRO FIORENTINI S.p.A.. PIETRO FIORENTINI S.p.A. shall not be held liable for damage to persons or property resulting from operations other than those described herein or carried out in ways other than as indicated.

#### WARNING!

Before conducting any work, make sure that the line on which the equipment is installed:

- has been shut off downstream and upstream;
- has been discharged.

After discharging the pressure from the line, trigger the slam-shut valve.

#### WARNING!

In case of doubt, do not perform any work. Contact PIETRO FIORENTINI S.p.A. for the necessary clarifications.

The management and/or use of the equipment includes interventions that are necessary as a result of normal use such as:

- inspection and checks;
- functional checks;
- routine maintenance;
- special maintenance.

#### NOTICE!

Maintenance work is strictly related to:

- the quality of the conveyed gas (impurities, humidity, gasoline, corrosive substances);
- the effectiveness of filtration;
- the equipment conditions of use.

To properly run the equipment, one should:

- follow the service frequency referred to in the manual for functional checks and routine maintenance.
- not exceed the time interval between one service and the next. The time interval is to be understood as the maximum acceptable; it can, however, be shortened;
- promptly check the causes of any anomalies such as excessive noise, leakage of fluids or similar and remedy them. The timely removal of any causes of anomaly and/or malfunction prevents further damage to the equipment and ensures operator safety;

Before beginning disassembly of the equipment, make sure that:

- the spare parts and parts used in replacements have adequate requirements to ensure the original performance of the equipment. Use original, compliant spare parts;
- the operator must have the necessary equipment (see chapter “7 - Commissioning/maintenance equipment”).

**! NOTICE!**

**The recommended spare parts are unambiguously identified with tags indicating:**

- **the assembly drawing number of the equipment where they are installed (see Chapter “12 - Recommended spare parts”);**
- **the position specified in the assembly drawing of the equipment.**

The equipment maintenance operations are divided, from an operational point of view, into three main categories:

### Commissioning and maintenance operations

<b>Periodic checks and inspections</b>	All those checks that the operator must carry out on a regular basis to ensure that the equipment is in proper working order.
<b>Routine maintenance</b>	All those operations that the operator must preventively carry out to ensure proper operation of the device over time. Routine maintenance includes: <ul style="list-style-type: none"> <li>• inspection;</li> <li>• control;</li> <li>• adjustment;</li> <li>• cleaning;</li> <li>• lubrication;</li> <li>• replacement;</li> </ul> of all spare parts.
<b>Special maintenance</b>	All those operations to be carried out by the operator when the equipment requires them.

Tab. 9.57

## 9.2 - PERIODICALLY CHECKING AND INSPECTING THE EQUIPMENT FOR PROPER OPERATION

Periodic checks and inspections	
<b>Operator qualification</b>	Mechanical maintenance technician
<b>PPE required</b>	 <p><b>WARNING!</b></p> <p>The PPE listed in this table is related to the risk associated with the equipment. For the PPE required to protect against risks associated with the workplace, installation or operating conditions, please refer to:</p> <ul style="list-style-type: none"> <li>the regulations in force in the country of installation;</li> <li>any information provided by the Safety Manager at the installation facility.</li> </ul>

Tab. 9.58

“Tab. 9.59” lists checks and verifications, i.e. operations that do not require any manual intervention on the individual equipment.

Some items thereof can be replaced remotely using suitable remote control tools. The following is listed below:

Activity description	Equipment/accessories involved	Evaluation criterion	Minimum frequency
<b>Significant performance check*</b>	Pressure regulators	<ul style="list-style-type: none"> <li>No fluctuations in the adjusted pressure.</li> <li>Significant pressure values within pre-set limits.</li> </ul>	Monthly
	Gas flow slam-shut type safety devices (external position indicator)	<ul style="list-style-type: none"> <li>Fully open position.</li> </ul>	
	Stand-by monitor (external position indicator)	<ul style="list-style-type: none"> <li>Fully open position.</li> </ul>	
<b>Visual inspection of the equipment outside condition</b>	All	<ul style="list-style-type: none"> <li>No visible damage.</li> <li>External surface protection as per UNI 9571-1:2012.</li> </ul>	Half-yearly

Tab. 9.59

\* These checks may be carried out remotely if there is a remote control system capable of analysing the significant performance of the equipment and of sending alerts/alarms when pre-set thresholds are reached.

## 9.3 - ROUTINE MAINTENANCE

### 9.3.1 - GENERAL SAFETY WARNINGS

#### **HAZARD!**

- Put the equipment in a safe condition (close the downstream shut-off valve and then the upstream one, and drain the line completely);
- ensure that the pressure upstream and downstream of the equipment is “0”.

#### **WARNING!**

After discharging the pressure from the line, trigger the slam-shut valve.

#### **NOTICE!**

Before installing new sealing elements (o-rings, diaphragm, etc.), they must be checked for integrity.



### 9.3.2 - REPLACEMENT FREQUENCY FOR COMPONENTS SUBJECT TO WEAR

**NOTICE!**

The following provisions shall apply to equipment components only.

The non-metallic parts of the equipment concerned are divided into the following two categories:

Preventive maintenance work	
<b>Category 1</b>	Parts subject to wear and/or abrasion, where: <ul style="list-style-type: none"> <li>wear and tear means the normal degradation of a part after prolonged use under normal operating conditions;</li> <li>abrasion is the mechanical action on the surface of the affected part resulting from the passage of gas under normal operating conditions.</li> </ul>
<b>Category 2</b>	Parts subject to aging only, including parts that also require lubrication and/or cleaning.

Tab. 9.60

**NOTICE!**

Check, within the minimum frequency specified in “Tab. 9.61”, the available components for wear/abrasion/aging.

Category	Part description	Evaluation criterion	Minimum replacement frequency
1	Valve seat sealing rings and non-metallic plugs	Pressure regulators	6 years
		Safety devices	
		Pressure safety system equipment	
1	Non-metallic parts with internal sealing function of valve seats and accessories of individual equipment	Pilots	6 years
		Pre-regulators	
		Accelerators	
		Any others	
1	Non-metallic parts with a sealing function between parts, at least one of which is in motion under normal working/operating conditions	Pressure regulators	6 years
		Gas flow slam-shut type safety devices	
		Relief devices with discharge to atmosphere	
1	Non-metallic parts with sealing function involved in disassembly operations during maintenance	Equipment subject to maintenance	6 years
2	Non-metallic parts providing feedback (sensing elements) of the controlled pressure of safety equipment	Safety equipment and/or accessories	6 years
2	Non-metallic parts with sealing and performance functions (diaphragms) of equipment	Pressure regulators and accessories	6 years
		Gas flow slam-shut type safety devices	6 years
		Relief device with discharge to atmosphere	6 years
2	Non-metallic parts of equipment with an internal sealing function: under normal operating conditions during maintenance	Relief valves	6 years
		Regulation lines disconnection equipment	If there are proven leaks
2	Non-metallic parts with a static sealing function only	Various equipment	If there are proven leaks

Category	Part description	Evaluation criterion	Minimum replacement frequency
2	Lubricating parts	Shut-off valves	Yearly
		Other equipment	Yearly
2	Filter elements	Filters	As needed

*Tab. 9.61*

## 9.4 - ROUTINE MAINTENANCE PROCEDURES

Routine maintenance	
Operator qualification	Operator qualification
PPE required	 <p><b>WARNING!</b></p> <p>The PPE listed in this table is related to the risk associated with the equipment. For the PPE required to protect against risks associated with the workplace, installation or operating conditions, please refer to:</p> <ul style="list-style-type: none"> <li>• the regulations in force in the country of installation;</li> <li>• <u>any information provided by the Safety Manager at the installation facility.</u></li> </ul>
Equipment required	Please refer to the chapter “7 - Commissioning/maintenance equipment”.

Tab. 9.62

**9.4.1 - TIGHTENING TORQUES**

**9.4.1.1 - TIGHTENING TORQUES FOR DIVAL 700 REGULATOR**

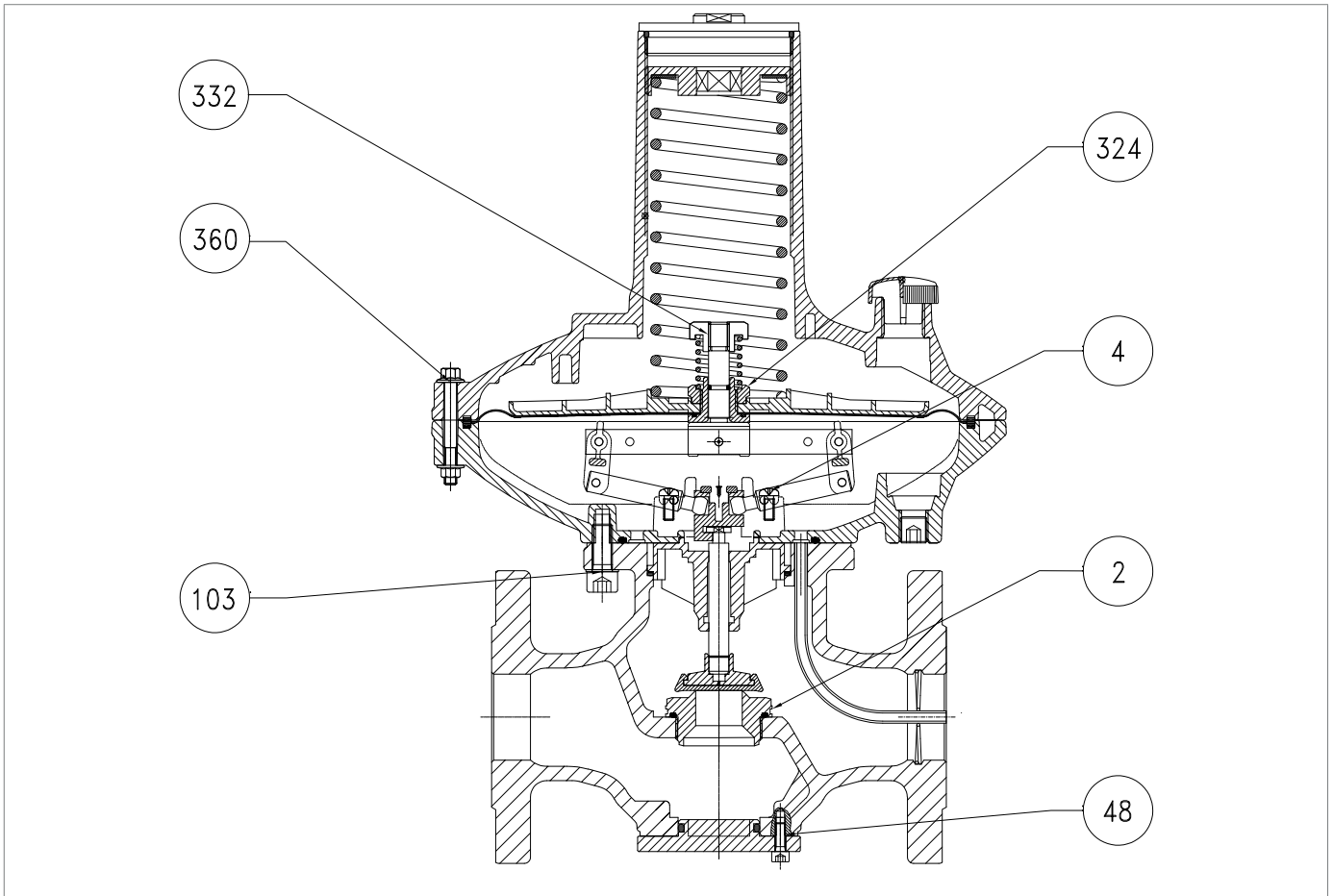

Fig. 9.25. Tightening torques DIVAL 700

**DIVAL 700 1" ; 1" ½; 2" - BP, MP, TR HEADS**

Pos.	Description	Torque (Nm)	Torque (ft - lb)
2	Valve seat	50	36
4	Screw M5x14 UNI 5931	4	2
48	Screw M5x12 UNI 8111	4	2
103	Screw M8X25 UNI 5931	14	10
324	Fixing nut	14	10
332	Fixing nut	4	2
360	Screw M6x50 DIN 6921	9	6

*Tab. 9.63*

**9.4.1.2 - TIGHTENING TORQUES OF REGULATOR WITH MONITOR FUNCTION**

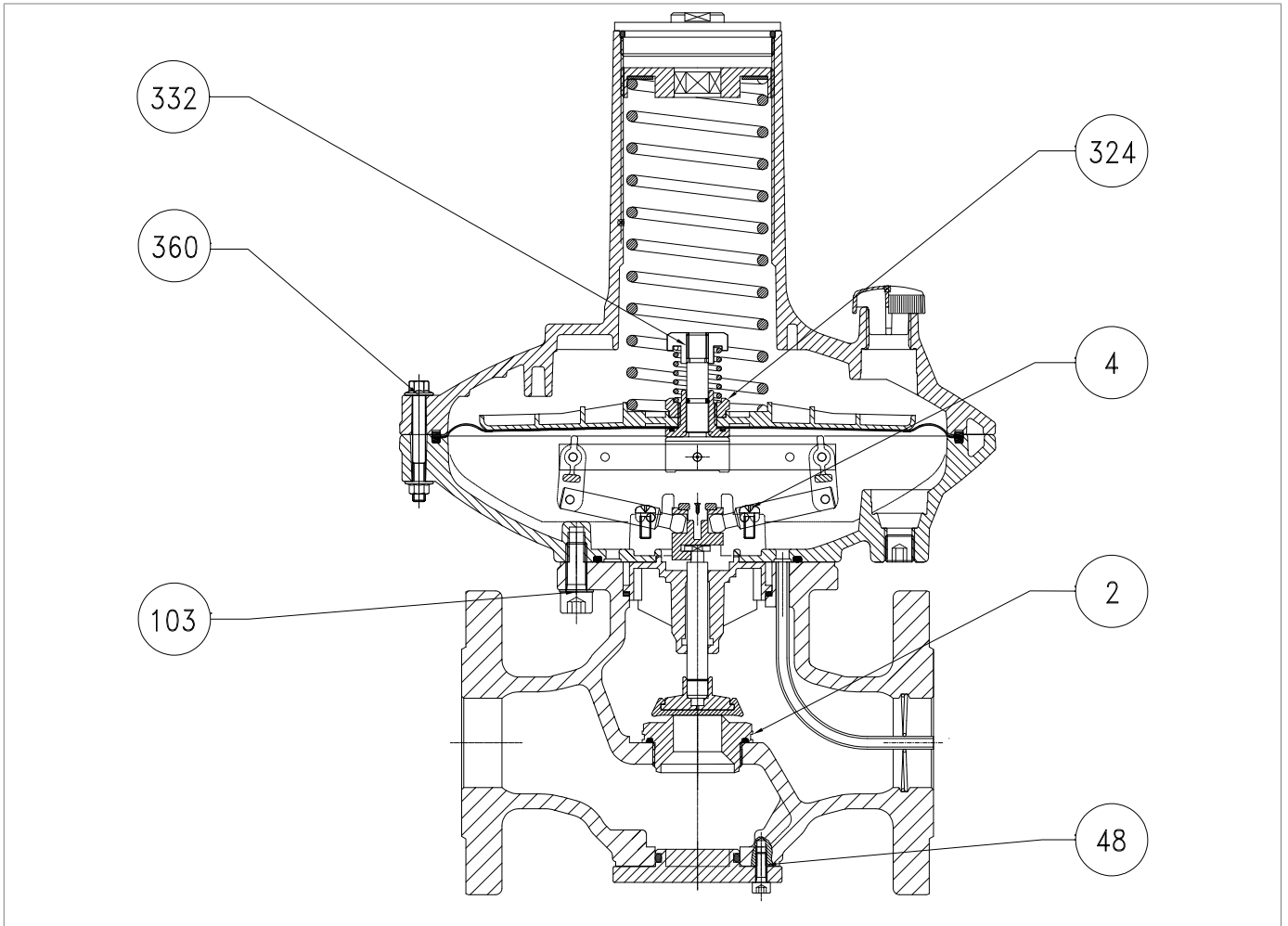

*Fig. 9.26. Regulator with monitor function tightening torques*

**DIVAL 700 WITH MONITOR FUNCTION**

Pos.	Description	Torque (Nm)	Torque (ft - lb)
2	Valve seat	50	36
4	Screw M5x14 UNI 5931	4	2
48	Screw M5x12 UNI 8111	4	2
103	Screw M8X25 UNI 5931	14	10
324	Fixing nut	14	10
332	Fixing nut	4	2
360	Screw M6x50 DIN 6921	9	6

*Tab. 9.64*

**9.4.1.3 - TIGHTENING TORQUE LA SLAM-SHUT VALVE**

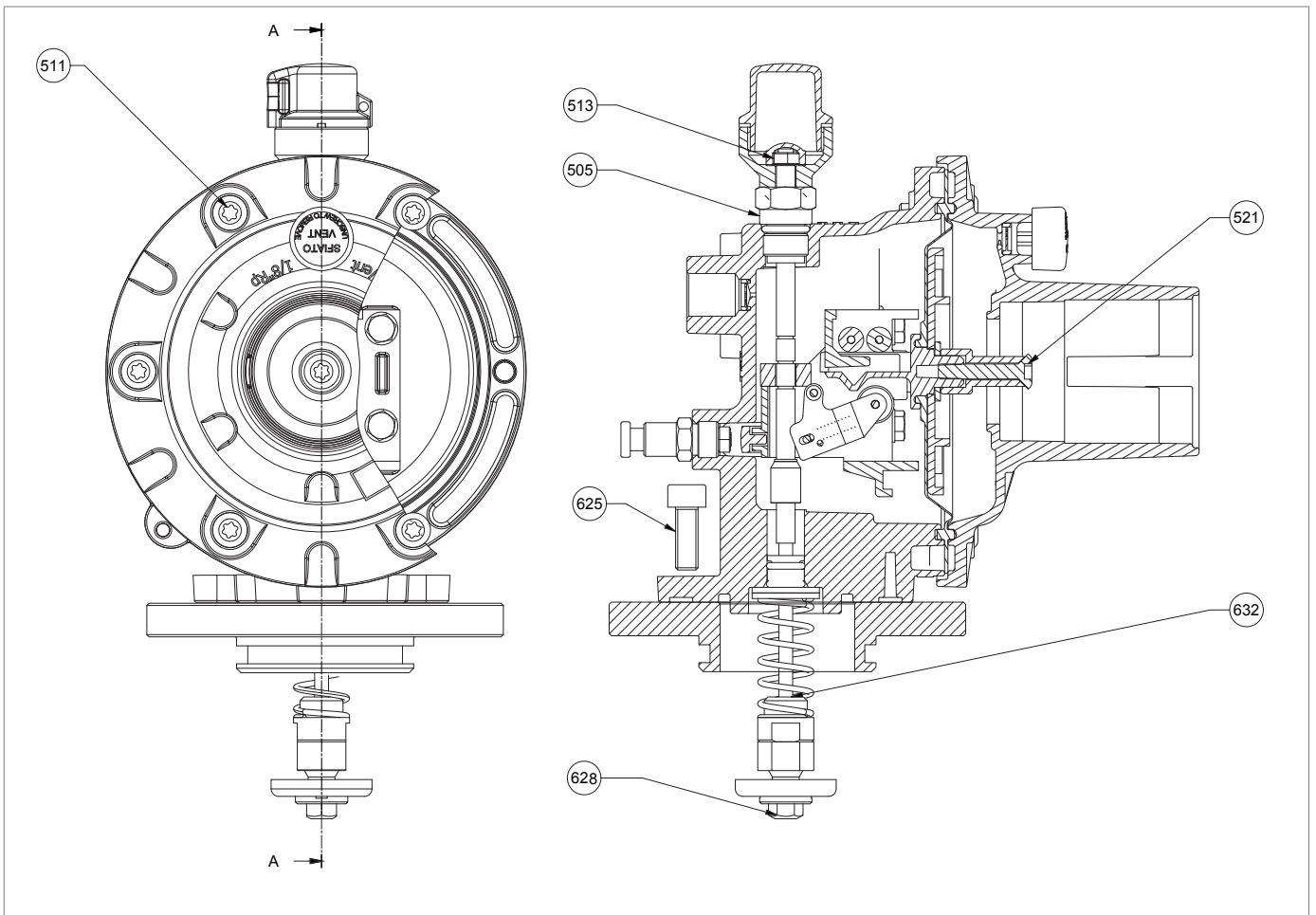

*Fig. 9.27. LA Slam-shut valve tightening torques*



**LA 1" ; 1" ½; 2 - BP, MP, TR HEADS**

<b>Pos.</b>	<b>Description</b>	<b>Torque (Nm)</b>	<b>Torque (ft - lb)</b>
505	Rod guide	4.5	3.3
511	TSC M5X20 TORX screw	2.5	1.8
513	M4 nut UNI 5588	1.5	0.8
521	TGS M4X27 TORX screw	4.5	3.3
625	Screw M5X14	4	3
628	Locking nut	1.5	1.1
632	Bushing	1.5	1.1

*Tab. 9.65*



## 9.4.2 - REPLACING ELEMENTS SUBJECT TO WEAR AND ABRASION

### 9.4.2.1 - INITIAL OPERATIONS

#### WARNING!

After discharging the pressure from the line, trigger the slam-shut valve.

#### ATTENTION!

Before carrying out any work, it is important to ensure that the line on which the regulator is installed has been shut off upstream and downstream, and discharged.

#### ATTENTION!

During assembly, make sure to tighten the screws as per the tables (tightening torques), according to the size for which maintenance is being carried out.

Proceed as follows:

Step	Action
1	Unscrew the conical fittings to disconnect all power sockets and sensing lines of the regulator.

Tab. 9.66

### 9.4.2.2 - CROSS DIAGRAM FOR TIGHTENING SCREWS

To tighten the screws, when required by the maintenance procedure, refer to the following diagram:

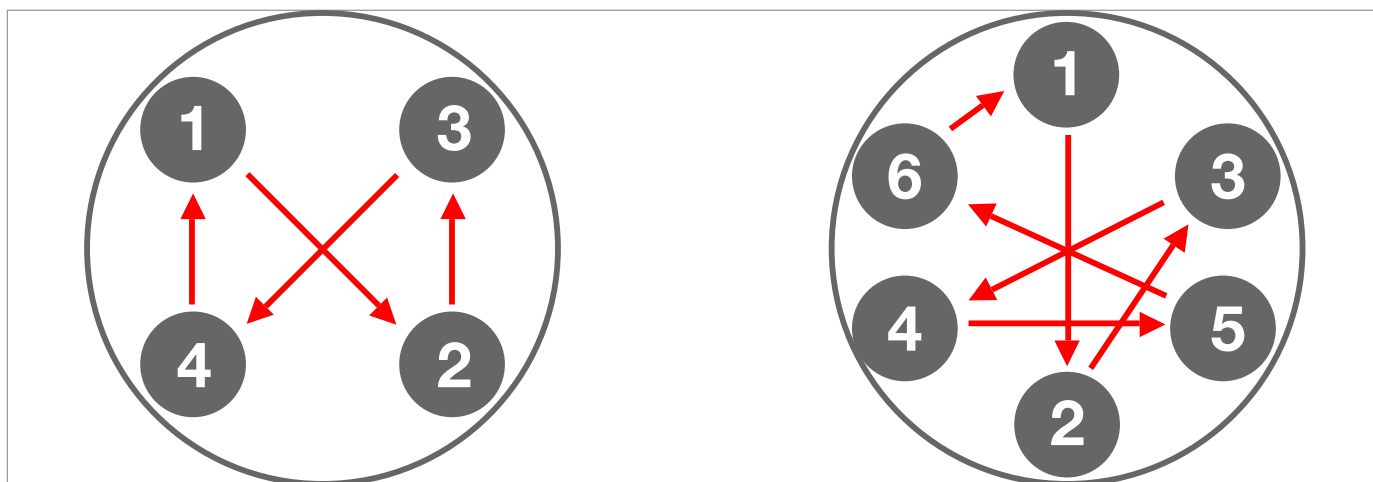

Fig. 9.28. Cross diagram

**9.4.3 - REGULATOR MAINTENANCE PROCEDURE DIVAL 700**

**9.4.3.1 - DIVAL 700 REGULATOR BP/MP HEADS**

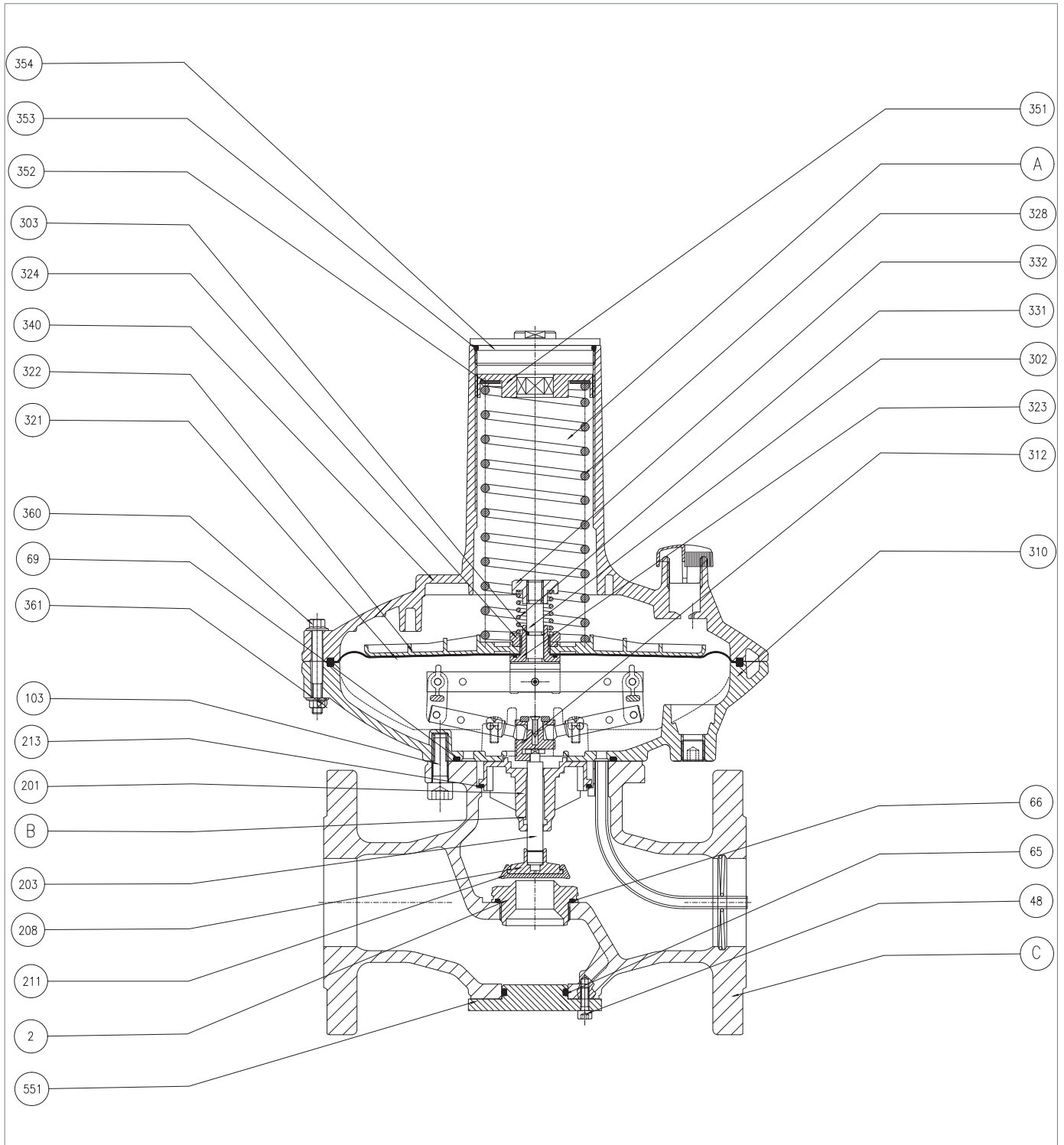





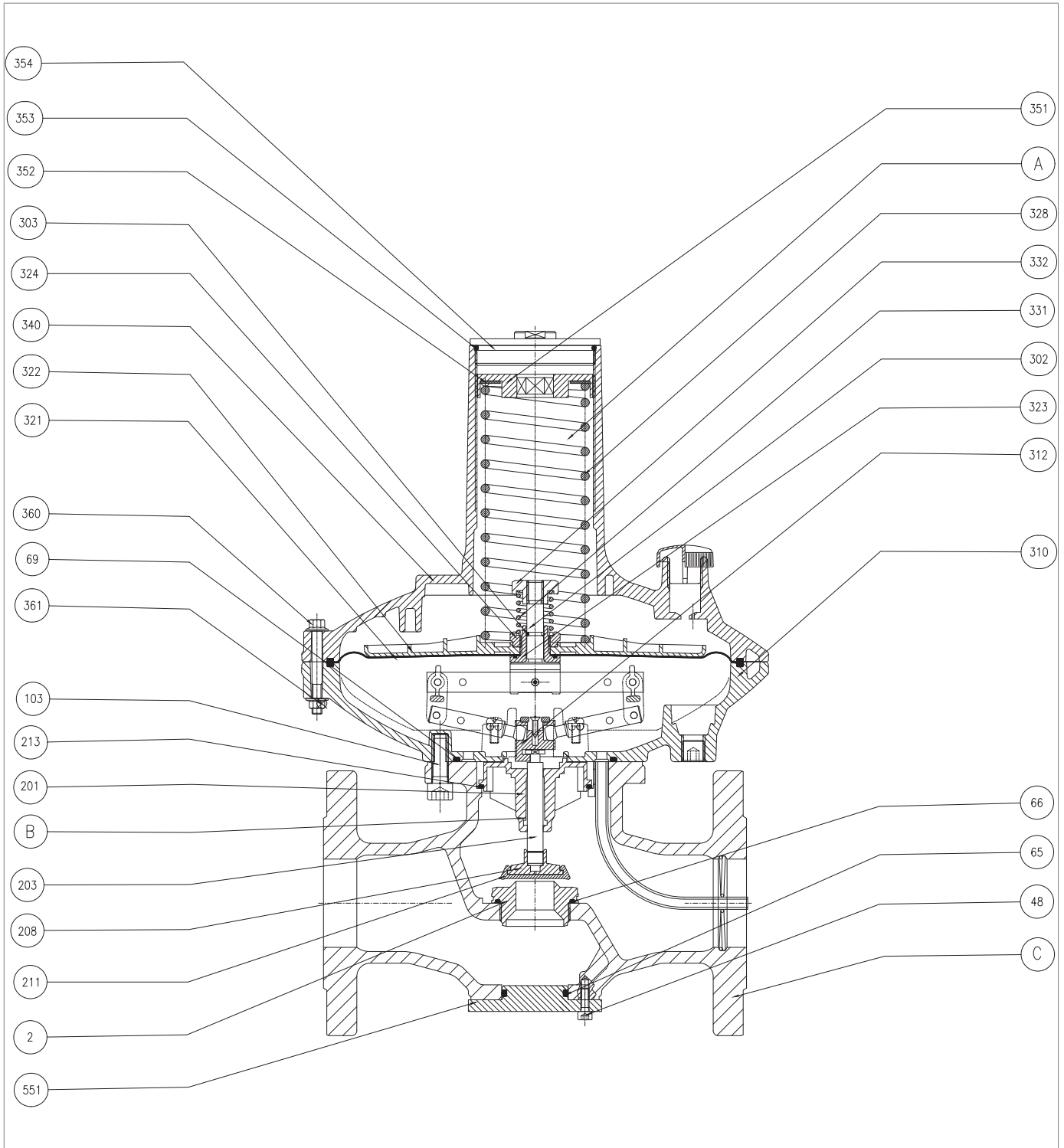







Fig. 9.29. DIVAL 700 Regulator BP/MP heads

Step	Action
1	Unscrew and remove the cap (354).
2	Remove the O-ring (353) and replace it, taking care to lubricate it with synthetic grease. <div style="border: 1px solid blue; padding: 5px;">  <b>NOTICE!</b>  <b>Before inserting the replacement O-ring, clean the retaining slots with a cleaning solution.</b> </div>
3	Unscrew and remove the ring nut (351) together with the washer (352). <div style="border: 1px solid blue; padding: 5px;">  <b>NOTICE!</b>  <b>Turn the ring nut anti-clockwise.</b> </div>
4	Remove the regulation spring (328).
5	Unscrew and remove the screws (103) securing the control head (A) to the body (C).
6	Remove the control head (A) together with the plug assembly (B).
7	Separate the plug assembly (B) from the control head (A). <div style="border: 1px solid blue; padding: 5px;">  <b>NOTICE!</b>  <b>Follow the direction of the arrow on the lower cover (310).</b> </div>
8	Unscrew and remove the nuts (361).
9	Undo and remove the screws (360).
10	Remove the upper cover (340) from the lower cover (310).
11	Unscrew and remove the locking nut (332).
12	Pull out the spring (331) of the relief valve.
13	Pull the diaphragm support assembly (321, 322, 323, 324) off the rod (302).
14	Remove the O-ring (303) and replace it, taking care to lubricate it with synthetic grease. <div style="border: 1px solid blue; padding: 5px;">  <b>NOTICE!</b>  <b>Before inserting the replacement O-ring, clean the retaining slots with a cleaning solution.</b> </div>
15	Unscrew and remove the locking nut (324). <div style="border: 1px solid blue; padding: 5px;">  <b>NOTICE!</b>  <b>During this phase, keep the diaphragm support (323) still.</b> </div>
16	Remove the diaphragm protection disc (322).
17	Remove and replace the main diaphragm (321).
18	Fit the diaphragm protection disc (322).
19	Insert and secure the locking nut (324), according to the tightening torques: <ul style="list-style-type: none"> <li>• “Tab. 9.63”</li> </ul> <div style="border: 1px solid blue; padding: 5px;">  <b>NOTICE!</b>  <b>During this phase, keep the diaphragm support (323) still.</b> </div>
20	Position the diaphragm support assembly (321, 322, 323, 324, 390) in the rod (302).
21	Insert the spring (331) of the relief valve.



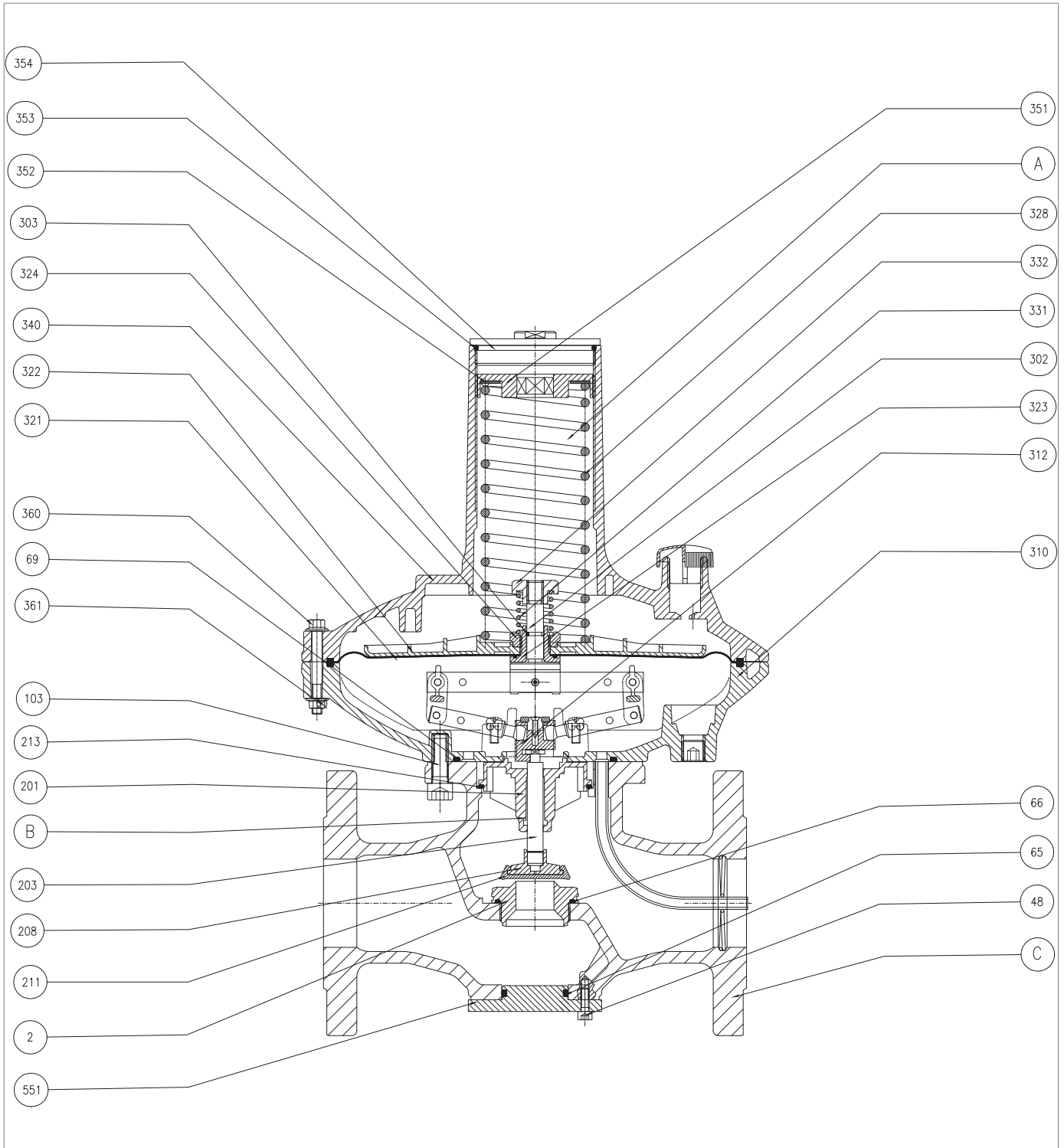

*DIVAL 700 Regulator BP/MP heads*

Step	Action
22	Insert and fix the nut (332) according to the following tightening torques: <ul style="list-style-type: none"> <li>• “Tab. 9.63”</li> </ul>
23	Place the upper cover (340) on the lower cover (310). <div style="border: 1px solid black; padding: 5px; margin-top: 5px;">  <b>NOTICE!</b>  <b>Follow the orientation of the anti-pumping valve when positioning the cover.</b> </div>
24	Insert and fix the screws (360) together with the nuts (361) according to the following tightening torques: <ul style="list-style-type: none"> <li>• “Tab. 9.63”</li> </ul> <div style="border: 1px solid black; padding: 5px; margin-top: 5px;">  <b>NOTICE!</b>  <b>Screw in as shown in the diagram at “9.4.2.2 - Cross diagram for tightening screws”.</b> </div>
25	Remove the O-ring (213) and replace it, taking care to lubricate it with synthetic grease. <div style="border: 1px solid black; padding: 5px; margin-top: 5px;">  <b>NOTICE!</b>  <b>Before inserting the replacement O-ring, clean the retaining slots with a cleaning solution.</b> </div>
26	Pull the plug holder (208) and plug (211) off the stem (203).
27	Remove and replace the plug (211) from the plug holder (208).
28	Place the plug holder (208) and plug (211) in the stem (203).
29	Unscrew and remove the valve seat (2) together with the O-ring (66).
30	Remove the O-ring (66) and replace it, taking care to lubricate it with synthetic grease. <div style="border: 1px solid black; padding: 5px; margin-top: 5px;">  <b>NOTICE!</b>  <b>Before inserting the replacement O-ring, clean the retaining slots with a cleaning solution.</b> </div>
31	Insert the valve seat (2) together with the O-ring (66) into the body (C) according to the tightening torques: <ul style="list-style-type: none"> <li>• “Tab. 9.63”</li> </ul>
32	Remove the O-ring (69) and replace it, taking care to lubricate it with synthetic grease. <div style="border: 1px solid black; padding: 5px; margin-top: 5px;">  <b>NOTICE!</b>  <b>Before inserting the replacement O-ring, clean the retaining slots with a cleaning solution.</b> </div>
33	Position the plug assembly (B) in the control head (A). <div style="border: 1px solid black; padding: 5px; margin-top: 5px;">  <b>NOTICE!</b>  <b>In the opposite direction indicated by the arrow on the lower cover (310).</b> </div>
34	Position the control head (A) and plug assembly (B) in the body (C).
35	Insert and fasten the screws (103) that secure the control head (A) to the body (C) according to the tightening torques: <ul style="list-style-type: none"> <li>• “Tab. 9.63”</li> </ul> <div style="border: 1px solid black; padding: 5px; margin-top: 5px;">  <b>NOTICE!</b>  <b>Screw in as shown in the diagram at “9.4.2.2 - Cross diagram for tightening screws”.</b> </div>
36	Insert the regulation spring (328).
37	Insert and secure the adjustment ring nut (351) together with the washer (352).
38	Insert and secure the plug (354) together with the O-ring (353).
39	Undo and remove the lower screws (48).
40	Remove the flange (551) together with the O-ring (65).



*DIVAL 700 Regulator BP/MP heads*



Step	Action
41	<p>Remove the O-ring (65) and replace it, taking care to lubricate it with synthetic grease.</p> <div style="border: 1px solid blue; padding: 2px;">  <b>NOTICE!</b>  <b>Before inserting the replacement O-rings, clean the retaining slots with a cleaning solution.</b> </div>
42	Position the flange (551) together with the O-ring (65).
43	<p>Insert and fix the lower screws (48) according to the following tightening torques:</p> <ul style="list-style-type: none"> <li>• “Tab. 9.63”</li> </ul> <div style="border: 1px solid blue; padding: 2px;">  <b>NOTICE!</b>  <b>Screw in as shown in the diagram at “9.4.2.2 - Cross diagram for tightening screws”.</b> </div>

Tab. 9.67

 **WARNING!**

**Ensure that all parts have been fitted correctly.**

**9.4.3.2 - DIVAL 700 REGULATOR TR HEAD**

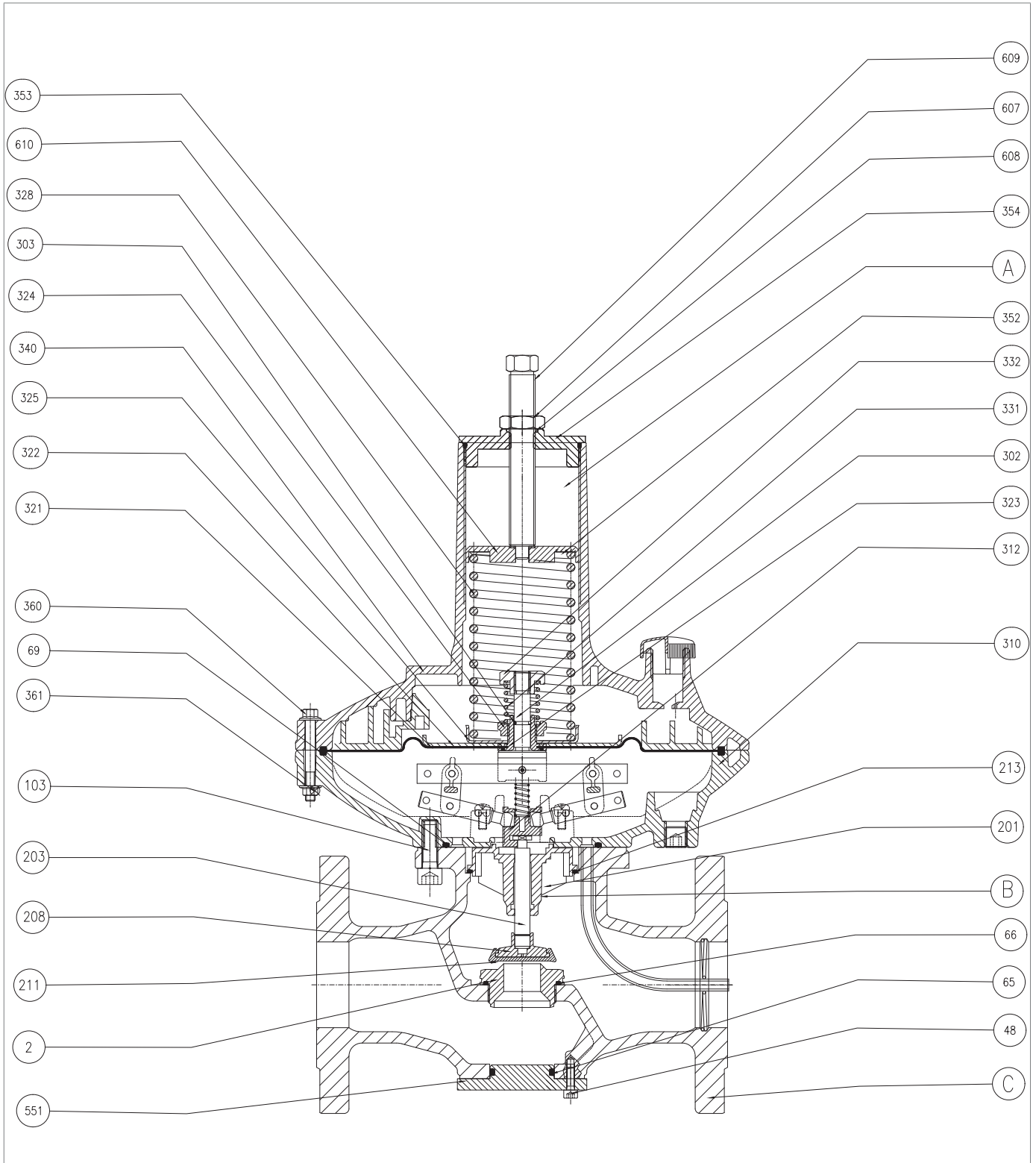
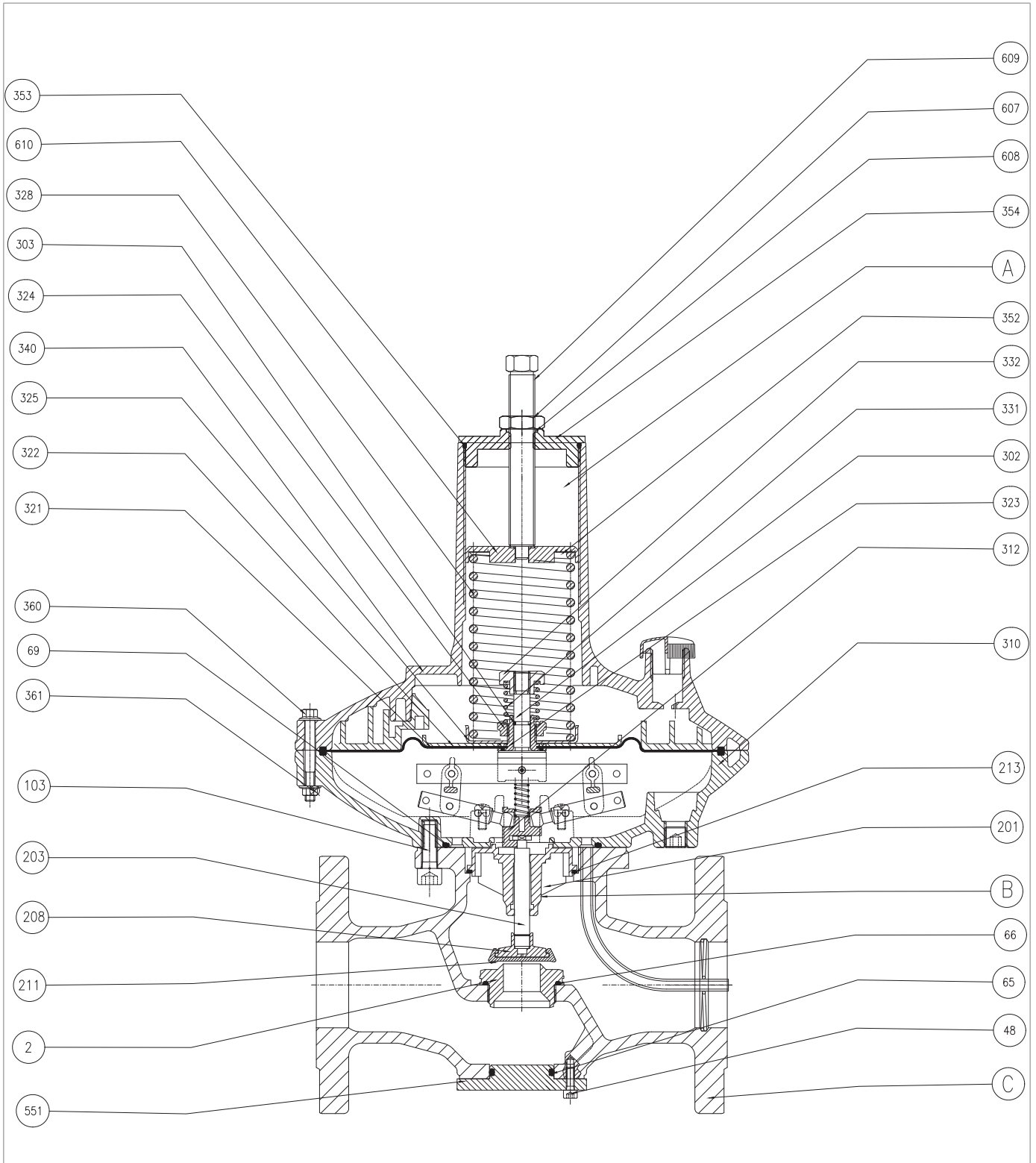

Fig. 9.30. DIVAL 700 Regulator TR head

Step	Action
1	Unscrew and remove the adjusting screw (609) together with the locking nut (607).
2	Remove and replace the O-rings (353, 608), taking care to lubricate them with synthetic grease. <div style="border: 1px solid blue; padding: 5px;"><b>NOTICE!</b></div> <b>Before inserting the replacement O-rings, clean the retaining slots with a cleaning solution.</b>
3	Remove the spring guide disc (610) together with the washer (352).
4	Remove the regulation spring (328).
5	Unscrew and remove the screws (103) securing the control head (A) to the body (C).
6	Remove the control head (A) together with the plug assembly (B).
7	Separate the plug assembly (B) from the control head (A). <div style="border: 1px solid blue; padding: 5px;"><b>NOTICE!</b></div> <b>Follow the indication of the arrow.</b>
8	Unscrew and remove the nuts (361).
9	Undo and remove the screws (360).
10	Remove the upper cover (340) from the lower cover (310).
11	Unscrew and remove the locking nut (332).
12	Pull out the spring (331) of the relief valve.
13	Pull the diaphragm support assembly (321, 322, 323, 324) off the rod (302).
14	Remove the O-ring (303) and replace it, taking care to lubricate it with synthetic grease. <div style="border: 1px solid blue; padding: 5px;"><b>NOTICE!</b></div> <b>Before inserting the replacement O-ring, clean the retaining slots with a cleaning solution.</b>
15	Unscrew and remove the locking nut (324). <div style="border: 1px solid blue; padding: 5px;"><b>NOTICE!</b></div> <b>During this phase, keep the diaphragm support (323) still.</b>
16	Remove the spring support (325).
17	Remove the diaphragm protection disc (322).
18	Remove and replace the main diaphragm (321).
19	Position the spring holder (325).
20	Fit the diaphragm protection disc (322).
21	Insert and secure the locking nut (324), according to the tightening torques: <ul style="list-style-type: none"> <li>• “Tab. 9.63”</li> </ul> <div style="border: 1px solid blue; padding: 5px;"><b>NOTICE!</b></div> <b>During this phase, keep the diaphragm support (323) still.</b>
22	Position the diaphragm support assembly (321, 322, 323, 324, 390) in the rod (302).
23	Insert the spring (331) of the relief valve.
24	Insert and fix the nut (332) according to the following tightening torques: <ul style="list-style-type: none"> <li>• “Tab. 9.63”</li> </ul>



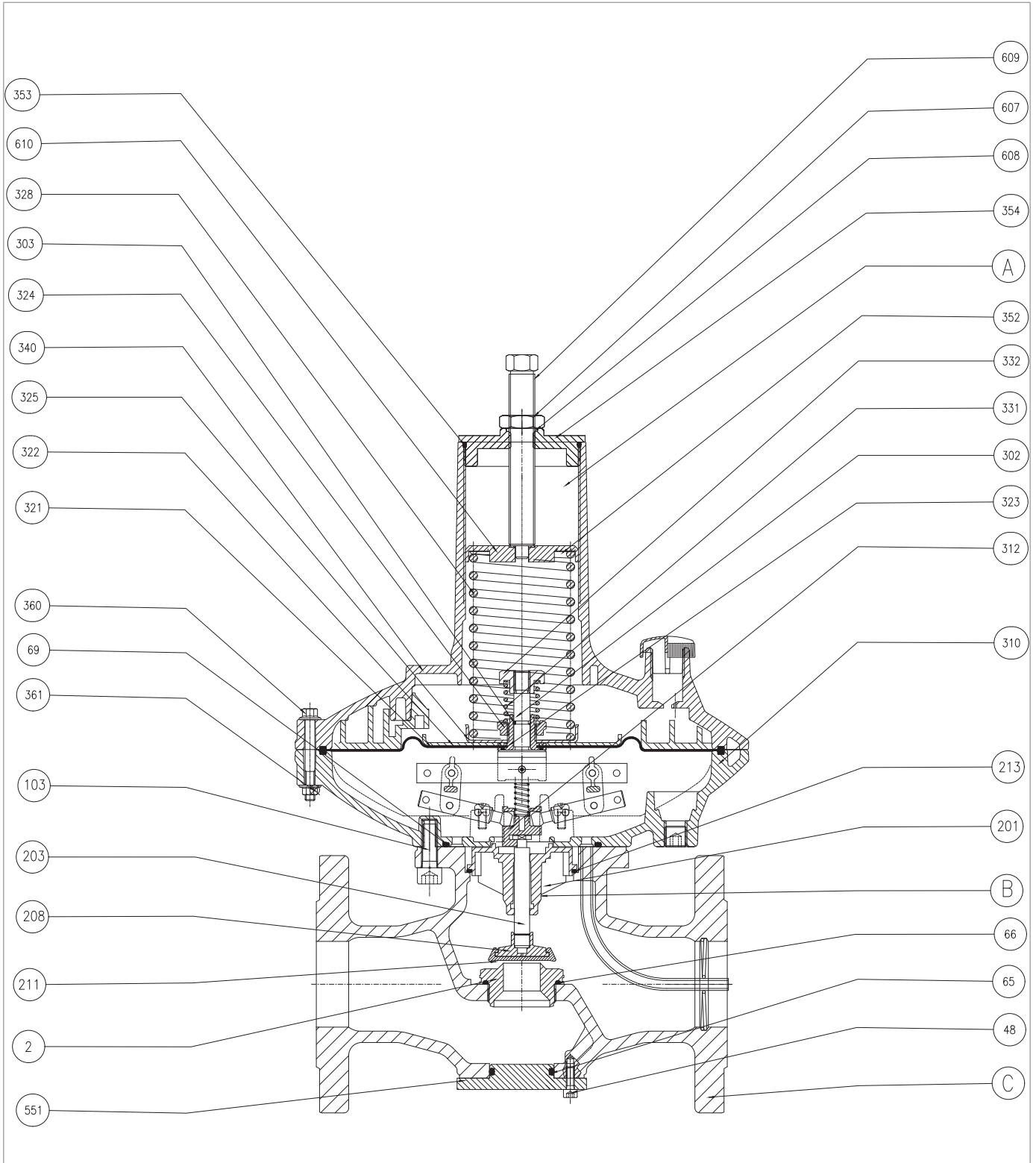

*DIVAL 700 Regulator TR head*

Step	Action
25	Place the upper cover (340) on the lower cover (310). <b>NOTICE!</b> <b>Follow the orientation of the anti-pumping valve when positioning the cover.</b>
26	Insert and fix the screws (360) together with the nuts (361) according to the following tightening torques: • “Tab. 9.63” <b>NOTICE!</b> <b>Screw in as shown in the diagram at “9.4.2.2 - Cross diagram for tightening screws”.</b>
27	Remove the O-ring (213) and replace it, taking care to lubricate it with synthetic grease. <b>NOTICE!</b> <b>Before inserting the replacement O-ring, clean the retaining slots with a cleaning solution.</b>
28	Pull the plug holder (208) and plug (211) off the stem (203).
29	Remove and replace the plug (211) from the plug holder (208).
30	Place the plug holder (208) and plug (211) in the stem (203).
31	Unscrew and remove the valve seat (2) together with the O-ring (66).
32	Remove the O-ring (66) and replace it, taking care to lubricate it with synthetic grease. <b>NOTICE!</b> <b>Before inserting the replacement O-ring, clean the retaining slots with a cleaning solution.</b>
33	Insert the valve seat (2) together with the O-ring (66) into the body (C) according to the tightening torques: • “Tab. 9.63”
34	Remove the O-ring (69) and replace it, taking care to lubricate it with synthetic grease. <b>NOTICE!</b> <b>Before inserting the replacement O-ring, clean the retaining slots with a cleaning solution.</b>
35	Position the plug assembly (B) in the control head (A). <b>NOTICE!</b> <b>In the opposite direction indicated by the arrow on the lower cover (310).</b>
36	Position the control head (A) and plug assembly (B) in the body (C).
37	Insert and fasten the screws (103) that secure the control head (A) to the body (C) according to the tightening torques: • “Tab. 9.63” <b>NOTICE!</b> <b>Screw in as shown in the diagram at “9.4.2.2 - Cross diagram for tightening screws”.</b>
38	Insert the regulation spring (328).
39	Insert the spring guide disc (610) together with washer (352).
40	Insert and secure the cap (354) together with the O-rings (353, 608).
41	Insert the adjusting screw (609) together with the locking nut (607) into the cap (354).
42	Undo and remove the lower screws (48).



*DIVAL 700 Regulator TR head*

Step	Action
43	Remove the flange (551) together with the O-ring (65).
44	Remove the O-ring (65) and replace it, taking care to lubricate it with synthetic grease. <div style="border: 1px solid blue; padding: 5px;">  <b>NOTICE!</b>  <b>Before inserting the replacement O-rings, clean the retaining slots with a cleaning solution.</b> </div>
45	Position the flange (551) together with the O-ring (65).
46	Insert and fix the lower screws (48) according to the following tightening torques: <ul style="list-style-type: none"> <li>• “Tab. 9.63”</li> </ul> <div style="border: 1px solid blue; padding: 5px;">  <b>NOTICE!</b>  <b>Screw in as shown in the diagram at “9.4.2.2 - Cross diagram for tightening screws”.</b> </div>

Tab. 9.68

 **WARNING!**

**Ensure that all parts have been fitted correctly.**

**9.4.4 - LA SLAM-SHUT VALVE**

**9.4.4.1 - LA SLAM-SHUT VALVE BP/MP HEADS**

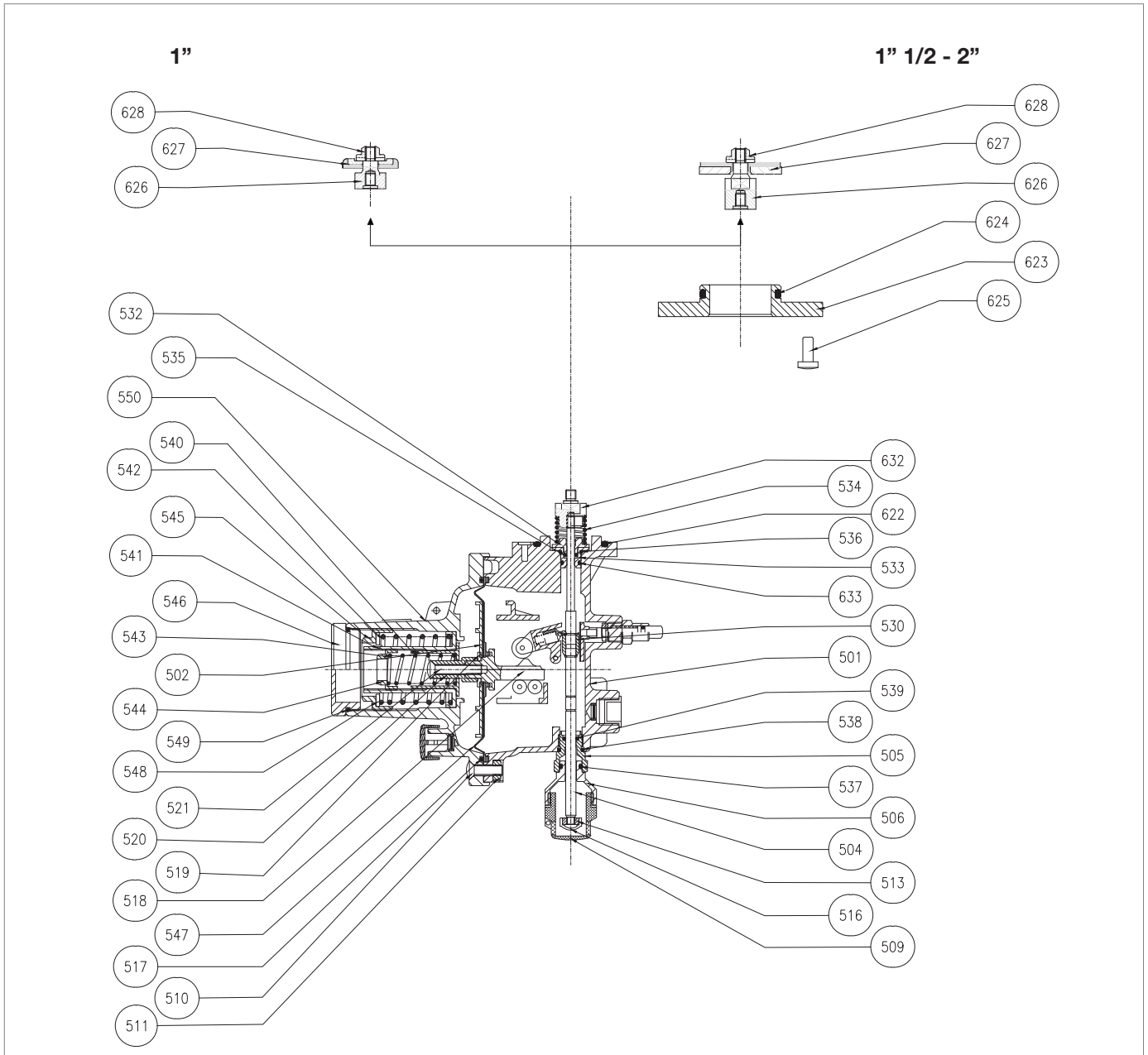







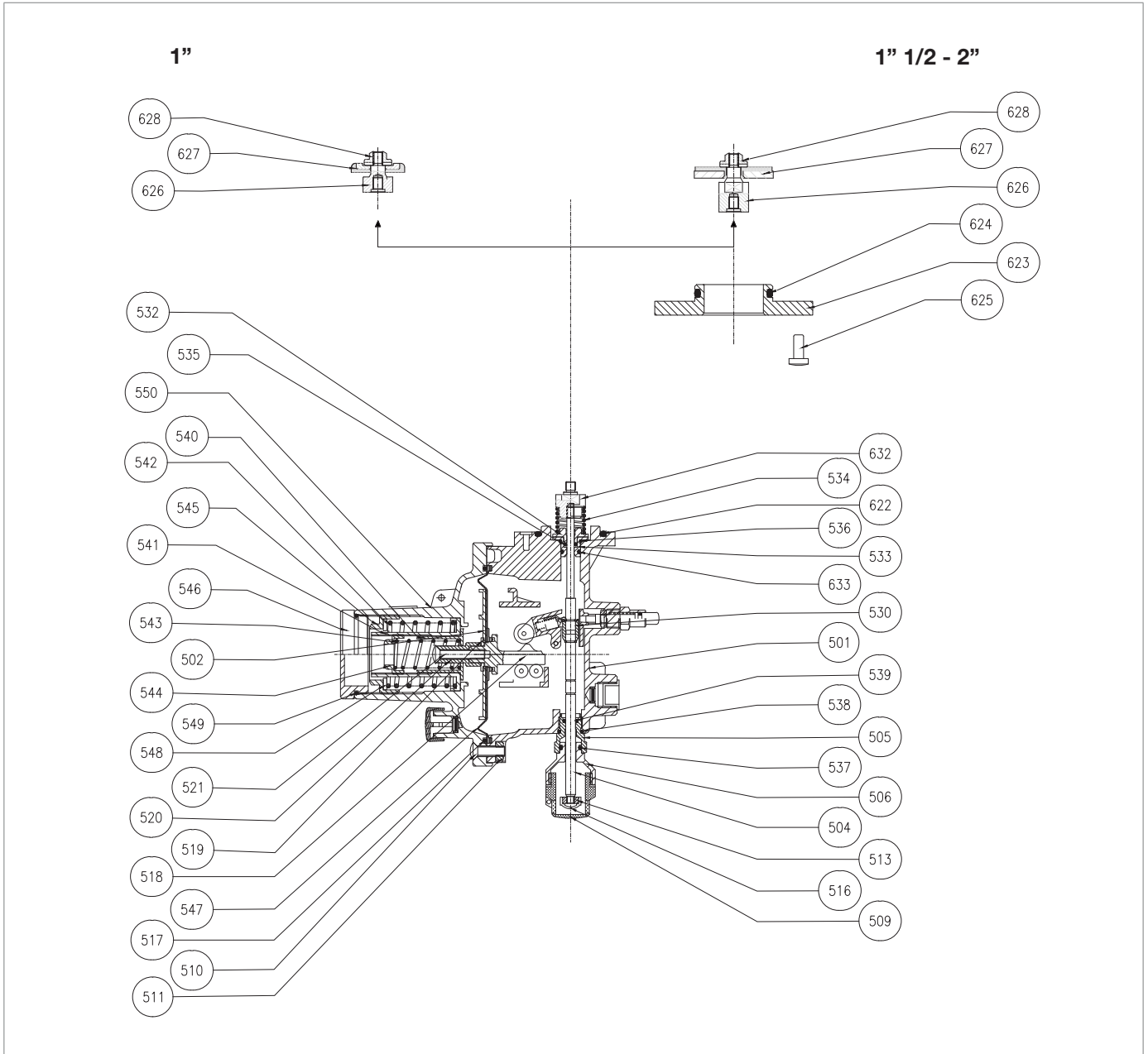







Fig. 9.31. LA slam-shut valve BP/MP heads



Step	Action
1	 <b>WARNING!</b> <b>Check that the slam-shut valve is in the closed position.</b>
2	 <b>ATTENTION!</b> <b>Before servicing, remove the LA slam-shut valve by unscrewing the screws (48) on the regulator (refer to “9.4.3 - Regulator Maintenance Procedure DIVAL 700”).</b>
3	Unscrew and remove the locking nut (628).  <b>NOTICE!</b> <b>During this step, hold the spacer (626) in place.</b>
4	Remove and replace the plug (627).
5	<b>APPLICABLE TO SIZES 1” ½ - 2” ONLY</b> Undo and remove the screws (625).
6	<b>APPLICABLE TO SIZES 1” ½ - 2” ONLY</b> Remove the flange (623).
7	<b>APPLICABLE TO SIZES 1” ½ - 2” ONLY</b> Remove the O-ring (624) and replace it, taking care to lubricate it with synthetic grease.  <b>NOTICE!</b> <b>Before inserting the replacement O-ring, clean the retaining slots with a cleaning solution.</b>
8	Remove the O-ring (622) and replace it, taking care to lubricate it with synthetic grease.  <b>NOTICE!</b> <b>Before inserting the replacement O-ring, clean the retaining slots with a cleaning solution.</b>
9	Unscrew and remove the cap (509).
10	Remove the cap (516).
11	Unscrew and remove the locking nut (513).
12	Remove the bushing (632).  <b>NOTICE!</b> <b>During this phase, keep the rod (504) still.</b>
13	Slide the rod (504) in the direction of the reset.
14	Pull off the knob (506).  <b>NOTICE!</b> <b>During this phase, keep the rod (504) still.</b>
15	Unscrew and remove the rod guide (505) together with the O-rings (537, 538, 539).
16	Replace the O-rings (537, 538, 539), lubricating them with synthetic grease.  <b>NOTICE!</b> <b>Before inserting the replacement O-rings, clean the retaining slots with a cleaning solution.</b>
17	Insert the rod guide (505) together with the O-rings (537, 538, 539), according to the tightening torques: <ul style="list-style-type: none"> <li>• “Tab. 9.65”</li> </ul>
18	Insert and secure the knob (506).
19	Remove the washer (532).



*LA slam-shut valve BP/MP heads*

Step	Action
20	Remove the rod guide (533) together with O-rings (535, 536, 633).
21	Remove and replace the O-rings (535, 536, 633), taking care to lubricate them with synthetic grease. <div style="border: 1px solid black; padding: 5px;">  <b>NOTICE!</b>  <b>Before inserting the replacement O-rings, clean the retaining slots with a cleaning solution.</b> </div>
22	Insert rod guide (533) together with O-rings (535, 536, 633).
23	Fit the washer (532).
24	Insert the rod (504) in the opposite direction to the reset.
25	Place the spring (534) in the washer (532). <div style="border: 1px solid black; padding: 5px;">  <b>NOTICE!</b>  <b>During this phase, keep the rod (504) still.</b> </div>
26	Position and secure the bushing (632) on the rod (504).
27	Position and secure the spacer (626). <div style="border: 1px solid black; padding: 5px;">  <b>NOTICE!</b>  <b>During this step, hold the bushing (632) in place.</b> </div>
28	Fit the plug (627).
29	Insert and secure the locking nut (628) according to the tightening torques: <ul style="list-style-type: none"> <li>• “Tab. 9.65”</li> </ul> <div style="border: 1px solid black; padding: 5px;">  <b>NOTICE!</b>  <b>Apply threadlocker glue</b> </div>
30	<b>APPLICABLE TO SIZES 1” ½ - 2” ONLY</b> Position the flange (623) in the body (501).
31	<b>APPLICABLE TO SIZES 1” ½ - 2” ONLY</b> Insert and fix the screws (625) according to the following tightening torques: <ul style="list-style-type: none"> <li>• “Tab. 9.65”</li> </ul> <div style="border: 1px solid black; padding: 5px;">  <b>NOTICE!</b>  <b>Screw in as shown in the diagram at “9.4.2.2 - Cross diagram for tightening screws”.</b> </div>
32	Insert and secure the locking nut (513) according to the tightening torques: <ul style="list-style-type: none"> <li>• “Tab. 9.65”</li> </ul>
33	Position the cap (516).
34	Insert and fix the cap (509).
35	Unscrew the cap (546) together with the O-ring (549).
36	Remove the O-ring (549) and replace it, taking care to lubricate it with synthetic grease. <div style="border: 1px solid black; padding: 5px;">  <b>NOTICE!</b>  <b>Before inserting the replacement O-ring, clean the retaining slots with a cleaning solution.</b> </div>
37	Unscrew the adjustment ring nut (545).
38	Pull out the maximum spring (542).
39	Remove spring holder (541).

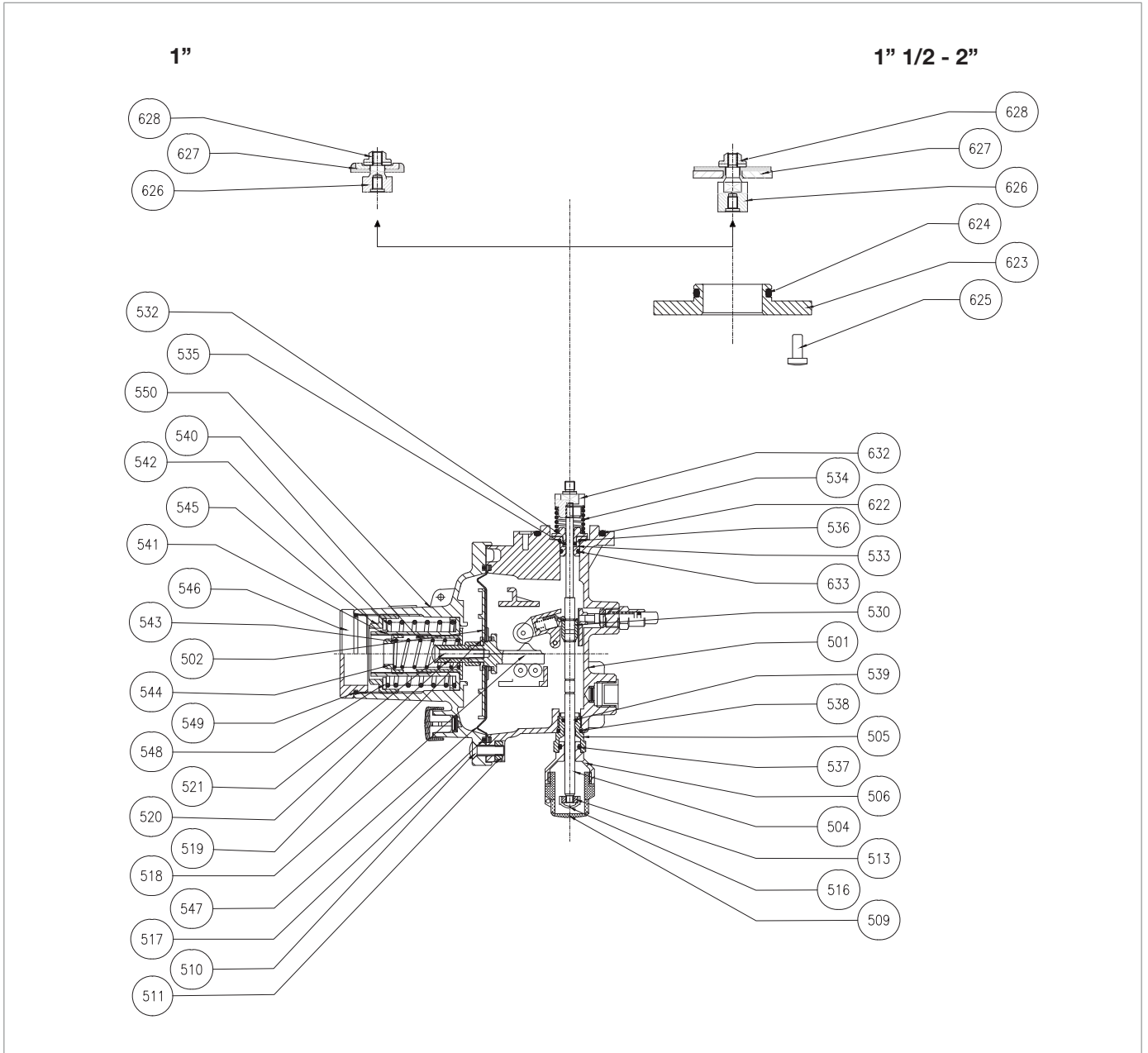

LA slam-shut valve BP/MP heads

Step	Action
40	Remove the spring guide (540). <b>NOTICE!</b> <b>If fitted, remove the minimum spring (543).</b>
41	Unscrew and remove the screws (510) together with the nuts (511).
42	Remove the cover (550) from the body (501).
43	Remove the diaphragm assembly: diaphragm (547), diaphragm protection disc (502), washer (519), diaphragm support (518), compression bushing (520), locking screw (521).
44	Undo and remove the locking screw (521). <b>NOTICE!</b> <b>During this phase, keep the diaphragm support (518) still.</b>
45	Unscrew and remove the compression bushing (520).
46	Remove the washer (519).
47	Remove the diaphragm protection disc (502).
48	Replace the diaphragm (547).
49	Fit the diaphragm protection disc (502).
50	Position washer (519).
51	Set compression bushing (520).
52	Insert and secure the clamping screw (521) in the diaphragm holder, according to the tightening torques: • “Tab. 9.65”
53	Place diaphragm assembly.
54	Insert cover (550) into body (501).
55	Insert and fix the screws (510) together with the nuts (511) according to the tightening torques: • “Tab. 9.65” <b>NOTICE!</b> <b>Screw in as shown in the diagram at “9.4.2.2 - Cross diagram for tightening screws”.</b>
56	Insert spring guide (540).
57	Insert spring holder (541).
58	Insert the maximum spring (542).
59	Insert and fasten adjustment ring nut (545)
60	Insert and secure the cap (546) together with the O-ring (549).
61	<b>ATTENTION!</b> <b>After maintenance, insert the LA slam-shut valve by fastening the screws (48) of the regulator (par. 9.4.3), according to the tightening torques</b> • “Tab. 9.65” <b>NOTICE!</b> <b>Screw in as shown in the diagram at “9.4.2.2 - Cross diagram for tightening screws”.</b>

Tab. 9.69

**WARNING!**

**Ensure that all parts have been fitted correctly.**

**9.4.4.2 - LA SLAM-SHUT VALVE TR HEADS**

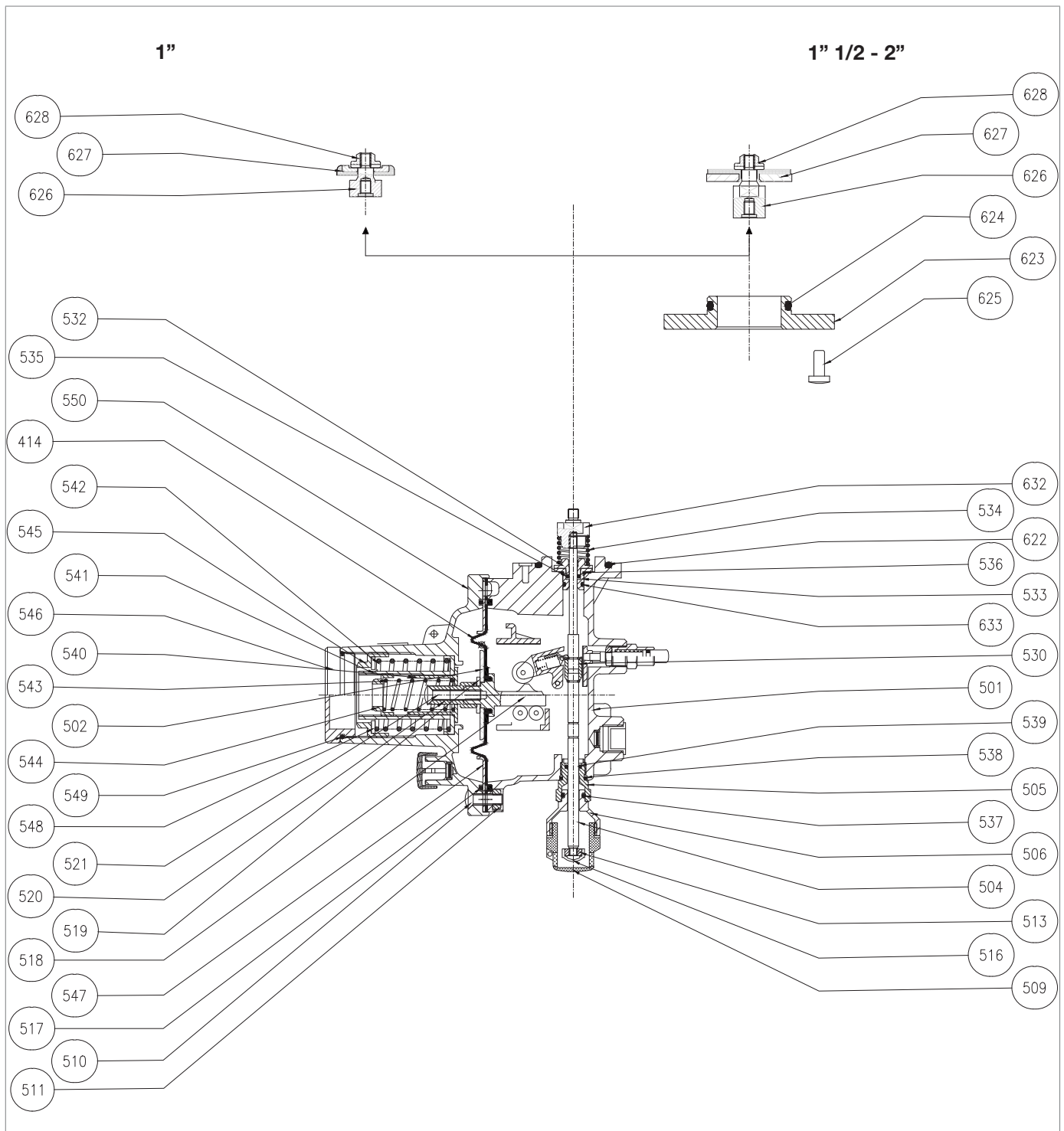







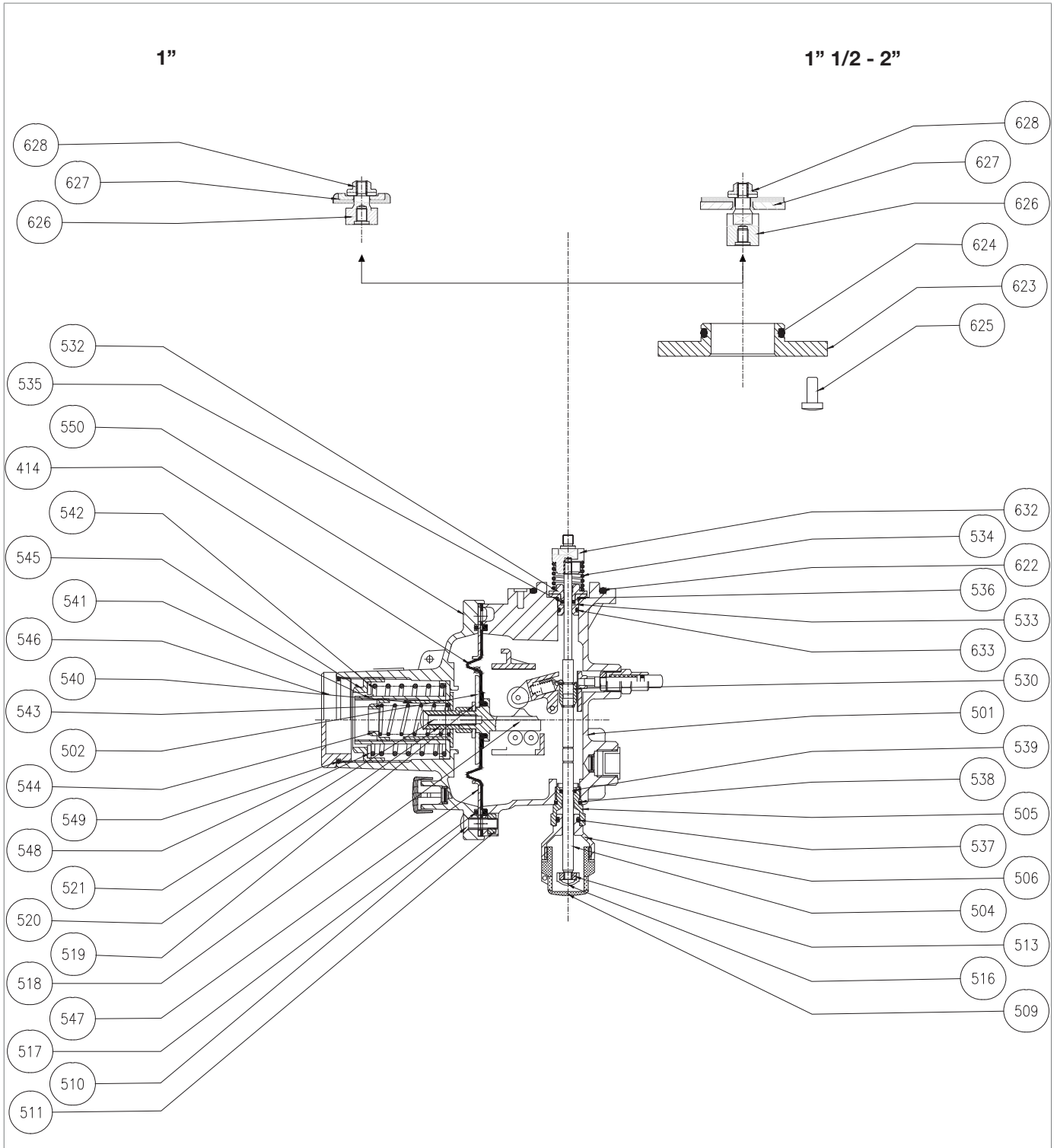









Fig. 9.32. LA slam-shut valve TR heads

Step	Action
1	 <b>WARNING!</b> <b>Check that the slam-shut valve is in the closed position.</b>
2	 <b>ATTENTION!</b> <b>Before servicing, remove the LA slam-shut valve by unscrewing the screws (48) on the regulator (refer to “9.4.3 - Regulator Maintenance Procedure DIVAL 700”).</b>
3	Unscrew and remove the locking nut (628).  <b>NOTICE!</b> <b>During this step, hold the spacer (626) in place.</b>
4	Remove and replace the plug (627).
5	<b>APPLICABLE TO SIZES 1” ½ - 2” ONLY</b> Undo and remove the screws (625).
6	<b>APPLICABLE TO SIZES 1” ½ - 2” ONLY</b> Remove the flange (623).
7	<b>APPLICABLE TO SIZES 1” ½ - 2” ONLY</b> Remove the O-ring (624) and replace it, taking care to lubricate it with synthetic grease.  <b>NOTICE!</b> <b>Before inserting the replacement O-ring, clean the retaining slots with a cleaning solution.</b>
8	Remove the O-ring (622) and replace it, taking care to lubricate it with synthetic grease.  <b>NOTICE!</b> <b>Before inserting the replacement O-ring, clean the retaining slots with a cleaning solution.</b>
9	Unscrew and remove the cap (509).
10	Remove the cap (516).
11	Unscrew and remove the locking nut (513).
12	Remove the bushing (632).  <b>NOTICE!</b> <b>During this phase, keep the rod (504) still.</b>
13	Slide the rod (504) in the direction of the reset.
14	Unscrew and remove the knob (506).  <b>NOTICE!</b> <b>During this phase, keep the rod (504) still.</b>
15	Unscrew and remove the rod guide (505) together with the O-rings (537, 538, 539).
16	Replace the O-rings (537, 538, 539), lubricating them with synthetic grease.  <b>NOTICE!</b> <b>Before inserting the replacement O-rings, clean the retaining slots with a cleaning solution.</b>
17	Insert rod guide (505) together with O-rings (537, 538, 539).
18	Insert and secure the knob (506).
19	Remove the washer (532).
20	Remove the rod guide (533) together with O-rings (535, 536, 633).





LA slam-shut valve TR header

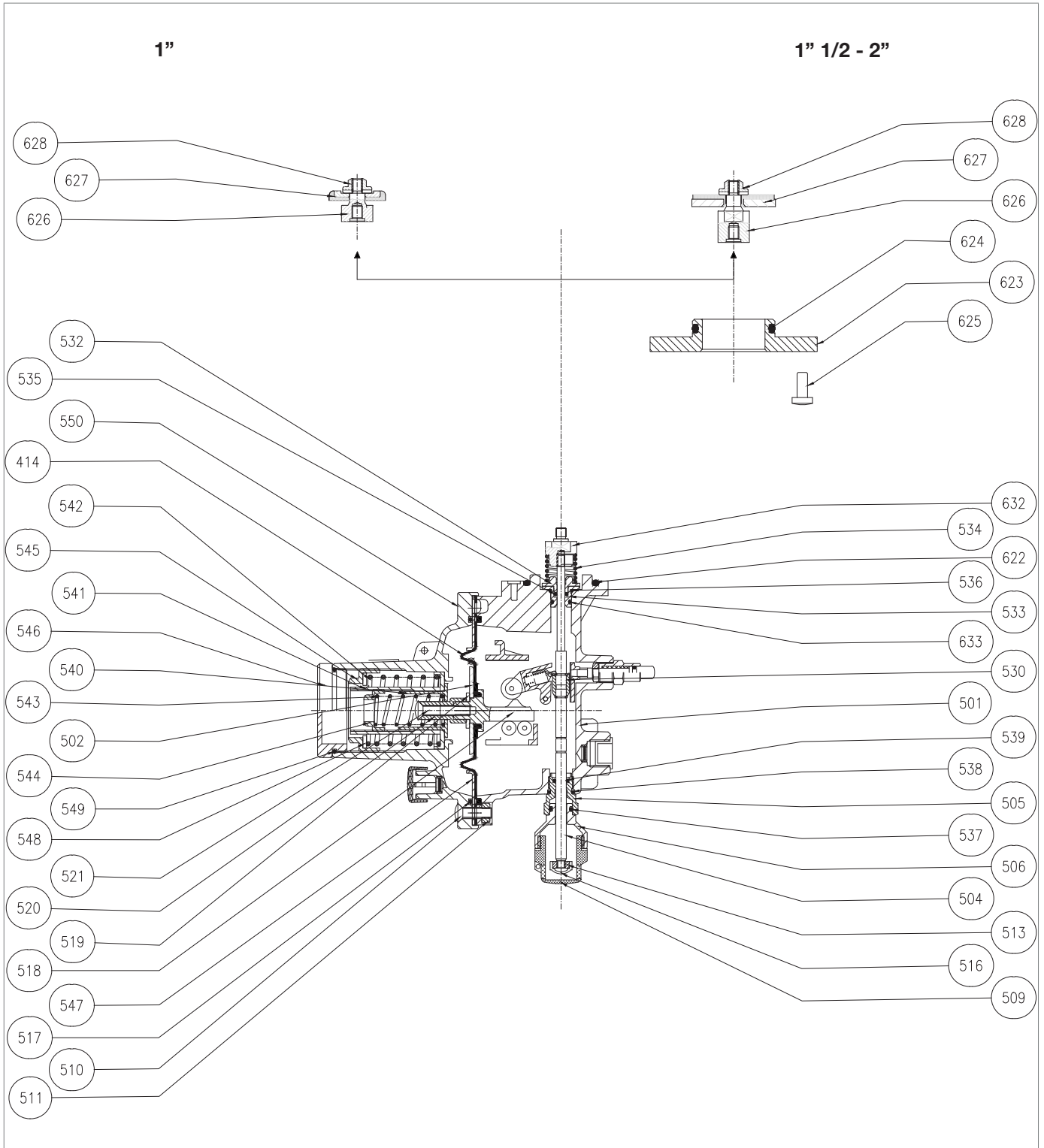

Step	Action
21	Remove and replace the O-rings (535, 536, 633), taking care to lubricate them with synthetic grease. <div style="border: 1px solid black; padding: 5px;">  <b>NOTICE!</b>  <b>Before inserting the replacement O-rings, clean the retaining slots with a cleaning solution.</b> </div>
22	Insert rod guide (533) together with O-rings (535, 536, 633).
23	Fit the washer (532).
24	Insert the rod (504) in the opposite direction to the reset.
25	Place the spring (534) in the washer (532). <div style="border: 1px solid black; padding: 5px;">  <b>NOTICE!</b>  <b>During this phase, keep the rod (504) still.</b> </div>
26	Position and secure the bushing (632) on the rod (504).
27	Position and secure the spacer (626). <div style="border: 1px solid black; padding: 5px;">  <b>NOTICE!</b>  <b>During this step, hold the bushing (632) in place.</b> </div>
28	Fit the plug (627).
29	Insert and secure the locking nut (628) according to the tightening torques: <ul style="list-style-type: none"> <li>• “Tab. 9.65”</li> </ul> <div style="border: 1px solid black; padding: 5px;">  <b>NOTICE!</b>  <b>Apply threadlocker glue</b> </div>
30	<b>APPLICABLE TO SIZES 1” ½ - 2” ONLY</b> Position the flange (623) in the body (501).
31	<b>APPLICABLE TO SIZES 1” ½ - 2” ONLY</b> Insert and fix the screws (625) according to the following tightening torques: <ul style="list-style-type: none"> <li>• “Tab. 9.65”</li> </ul> <div style="border: 1px solid black; padding: 5px;">  <b>NOTICE!</b>  <b>Screw in as shown in the diagram at “9.4.2.2 - Cross diagram for tightening screws”.</b> </div>
32	Insert and secure the locking nut (513) according to the tightening torques: <ul style="list-style-type: none"> <li>• “Tab. 9.65”</li> </ul>
33	Position the cap (516).
34	Insert and fix the cap (509).
35	Unscrew the cap (546) together with the O-ring (549).
36	Remove the O-ring (549) and replace it, taking care to lubricate it with synthetic grease. <div style="border: 1px solid black; padding: 5px;">  <b>NOTICE!</b>  <b>Before inserting the replacement O-ring, clean the retaining slots with a cleaning solution.</b> </div>
37	Unscrew the adjustment ring nut (545).
38	Pull out the maximum spring (542).
39	Remove spring holder (541).
40	Remove the spring guide (540). <div style="border: 1px solid black; padding: 5px;">  <b>NOTICE!</b>  <b>If fitted, remove the minimum spring (543).</b> </div>



*LA slam-shut valve TR header*

Step	Action
41	Unscrew and remove the screws (510) together with the nuts (511).
42	Remove the cover (550) from the body (501).
43	Remove the diaphragm assembly: diaphragm (547), diaphragm protection disc (502), washer (519), diaphragm support (518), compression bushing (520), locking screw (521).
44	Undo and remove the locking screw (521). <div style="border: 1px solid blue; padding: 5px;">  <b>NOTICE!</b>  <b>During this phase, keep the diaphragm support (518) still.</b> </div>
45	Unscrew and remove the compression bushing (520).
46	Remove the washer (519).
47	Remove the diaphragm protection disc (502).
48	Replace the diaphragm (547).
49	Fit the diaphragm protection disc (502).
50	Position washer (519).
51	Set compression bushing (520).
52	Insert and secure the clamping screw (521) in the diaphragm holder, according to the tightening torques: <ul style="list-style-type: none"> <li>• “Tab. 9.65”</li> </ul>
53	Place diaphragm assembly.
54	Insert cover (550) into body (501).
55	Insert and fix the screws (510) together with the nuts (511) according to the tightening torques: <ul style="list-style-type: none"> <li>• “Tab. 9.65”</li> </ul>
56	Insert spring guide (540).
57	Insert spring holder (541).
58	Insert the maximum spring (542).
59	Insert and fasten adjustment ring nut (545)
60	Insert and secure the cap (546) together with the O-ring (549).
61	<div style="background-color: yellow; padding: 5px;">  <b>ATTENTION!</b>  <b>After maintenance, insert the LA slam-shut valve by fastening the screws (48) of the regulator (par. 9.4.3), according to the tightening torques</b> <ul style="list-style-type: none"> <li>• “Tab. 9.65”</li> </ul> </div> <div style="border: 1px solid blue; padding: 5px;">  <b>NOTICE!</b>  <b>Screw in as shown in the diagram at “9.4.2.2 - Cross diagram for tightening screws”.</b> </div>

Tab. 9.70

 **WARNING!**

**Ensure that all parts have been fitted correctly.**

#### 9.4.6 - PROCEDURE FOR RECOMMISSIONING AFTER MAINTENANCE

 **NOTICE!**

For the re-commissioning procedure, please follow the instructions in section “8.5 - Regulator commissioning procedure”

## 10 - TROUBLESHOOTING

Listed below are the cases (causes and tripping) that could occur in the form of malfunctions of various kinds over time. These situations depend on the conditions of the gas as well as on the natural ageing and wear of the materials.

### 10.1 - GENERAL WARNINGS

#### **HAZARD!**

**Maintenance work must be carried out by qualified personnel:**

- trained on workplace safety also based on the regulations in force in the place of installation of the work equipment;
- qualified and authorised to carry out activities related to the equipment.

#### **WARNING!**







**PIETRO FIORENTINI S.p.A. shall not be held liable for any damage to people and property due to services:**

- other than those described;
- performed according to methods other than those specified;
- carried out by unsuitable personnel.

#### **NOTICE!**

**If an operating fault occurs and qualified personnel are not available for the specific service, call the PIETRO FIORENTINI S.p.A. Authorised Assistance Centre**

## 10.2 - OPERATOR QUALIFICATION SPECIFICATION

Commissioning	
<b>Operator qualification</b>	<ul style="list-style-type: none"> <li>• Mechanical maintenance technician;</li> <li>• Electrical maintenance technician;</li> <li>• Installer;</li> <li>• Name of the user.</li> </ul>
<b>PPE required</b>	<div style="display: flex; align-items: center; gap: 10px;">      </div> <div style="background-color: #f4a460; padding: 5px; margin-top: 5px;">  <b>WARNING!</b> </div> <p>The PPE listed in this table is related to the risk associated with the equipment. For the PPE required to protect against risks associated with the workplace, installation or operating conditions, please refer to:</p> <ul style="list-style-type: none"> <li>• the regulations in force in the country of installation;</li> <li>• <u>any information provided by the Safety Manager at the installation facility.</u></li> </ul>
<b>Equipment required</b>	Please refer to the chapter “7 - Commissioning/maintenance equipment”.

Tab. 10.71

## 10.3 - TROUBLESHOOTING PROCEDURES

For proper troubleshooting, proceed as follows:

- close the downstream shut-off valves;
- refer to the troubleshooting tables listed below.

## 10.4 - TROUBLESHOOTING TABLES

### NOTICE!

See chapter “9 - Maintenance and functional checks” for pictures of the regulator DIVAL 700 and its accessories.

### 10.4.1 - TROUBLESHOOTING DIVAL 700 REGULATOR

Failure	Possible causes	Intervention
<b>Failed sealing or zero flow rate</b>	Valve seat (2) damaged	Replace
	Plug (211) damaged	Replace
	O-ring (202) damaged	Replace
	O-ring (213) damaged	Replace
	O-ring (215) damaged	Replace
	Diaphragm (209) damaged	Replace
	Dirt or presence of foreign bodies in the sealing area	Clean
<b>Pumping</b>	Plug rod assembly friction	Clean and replace if needed
	Blocked anti-pumping valves	Clean and replace if needed
	Reduced downstream volumes	Increase the volume
<b>Downstream pressure increases on delivery</b>	Broken or damaged diaphragm (321)	Replace
	Broken or damaged diaphragm (209)	Replace

Tab. 10.72

### 10.4.2 - LA SLAM-SHUT VALVE TROUBLESHOOTING

Failure	Possible causes	Intervention
<b>Slam-shut valve failed to trip</b>	Rod (501) locked in opening	Clean and reposition if needed
<b>External leak</b>	Broken diaphragm (517)	Replace
<b>Downstream pressure (Pd) increases in open valve position</b>	O-ring (521) not sealing	Replace
	O-ring (523) not sealing	Replace
	Rod (501) damaged	Replace
<b>Downstream pressure (Pd) increases in closed valve position</b>	O-ring (521) not sealing	Replace
	Rod (501) damaged	Replace
	Reinforced gasket (528) damaged	Replace
	Valve seat (102) damaged	Replace
	Damaged valve seat O-ring (104)	Replace
<b>Slam-shut valve failed to trip due to pressure increase</b>	Broken diaphragm (517)	Replace
<b>Slam-shut valve failed to trip due to pressure decrease</b>	Broken diaphragm (517)	Replace

Tab. 10.73





## 11 - UNINSTALLATION AND DISPOSAL

### 11.1 - GENERAL SAFETY WARNINGS

#### HAZARD!



Make sure that there are no potentially explosive ignition sources in the work area set up to uninstall and/or dispose of the equipment.

#### WARNING!

Before proceeding with uninstallation and disposal, make the equipment safe by disconnecting it from any power supply.

### 11.2 - QUALIFICATION OF THE OPERATORS IN CHARGE

#### Commissioning

Operator qualification	Installer
PPE required	 <p> <b>WARNING!</b></p> <p>The PPE listed in this table is related to the risk associated with the equipment. For the PPE required to protect against risks associated with the workplace, installation or operating conditions, please refer to:</p> <ul style="list-style-type: none"> <li>• the regulations in force in the country of installation;</li> <li>• any information provided by the Safety Manager at the installation facility.</li> </ul>
Equipment required	Please refer to the chapter "7 - Commissioning/maintenance equipment".

Tab. 11.74

### 11.3 - UNINSTALLATION

#### ATTENTION!

Before uninstalling the equipment, completely drain the fluid in the reduction line and inside the equipment.

#### NOTICE!

For equipment uninstallation procedures, please refer to the installation procedures (see chapter "6 - installation"), proceeding in reverse order.

### 11.4 - INFORMATION REQUIRED IN CASE OF RE-INSTALLATION

#### NOTICE!

Should the equipment be reused after uninstallation, refer to chapters:

- "6 - installation";
- "8 - Commissioning".

## 11.5 - DISPOSAL INFORMATION

### NOTICE!

**Bear in mind that the laws in force in the country of installation must be complied with. Illegal or improper disposal involves the application of the penalties provided for by the legislation in force in the country of installation.**

### NOTICE!

**Proper disposal prevents damage to humans and the environment and promotes the reuse of precious raw materials.**

The equipment was manufactured with materials that can be recycled by specialised companies. For proper disposal of the equipment, proceed as specified in “Tab. 11.75”:

Step	Action
1	Set up a large work area free from obstacles where to safely dismantle the equipment.
2	Sort the various components by type of material for easier recycling through separate collection.
3	Send the materials obtained in <b>Step 2</b> to a specialised company.

Tab. 11.75

The equipment in any configuration consists of the following materials:

Material	Disposal/recycling indications
Plastic	It must be dismantled and disposed of separately.
Lubricants/Oils	They must be collected and delivered to the appropriate specialised and authorised collection and disposal centres.
Steel/Cast Iron	Disassemble and collect separately. It must be recycled through the specific collection centres.
Stainless steel	Disassemble and collect separately. It must be recycled through the specific collection centres.
Aluminium	Disassemble and collect separately. It must be recycled through the specific collection centres.
Pneumatic/electric components	They must be dismantled in order to be reused if they are still in good condition or, if possible, overhauled and recycled.

Tab. 11.76

### NOTICE!

**Please refer to the chapter “9 - Maintenance and functional checks” to better identify the composition of the equipment and its parts.**

## 12 - RECOMMENDED SPARE PARTS

### 12.1 - GENERAL WARNINGS

 **NOTICE!**

If non-original spare parts are used, PIETRO FIORENTINI S.p.A. their declared performance cannot be guaranteed.

It is recommended to use original spare parts PIETRO FIORENTINI S.p.A.

PIETRO FIORENTINI S.p.A. shall not be held liable for any damage caused by using non-original parts.

### 12.2 - HOW TO REQUEST SPARE PARTS

 **NOTICE!**

For specific information, please refer to the sales network of PIETRO FIORENTINI S.p.A.



## 13 - FLOW RATE TABLES

### 13.1 - CALIBRATION TABLE FOR SLAM-SHUT VALVE

LA/BP "Max pressure"							
Pos.	Spring item code	Spring colour	d	Lo	De	Min.	Max.
1	64470112	Red	2.2	44	34	0.03	0.049
2	64470115	Grey	2.8	42	34	0.05	0.18

**d** = Wire Diameter (mm)    **Lo** = Spring Length (mm)    **De** = External Diameter (mm)    **Min./Max.** = pressure (bar)

Tab. 13.77

LA/BP "Min pressure"							
Pos.	Spring item code	Spring colour	d	Lo	De	Min.	Max.
1	64470024	White	1.3	45	15	0.006	0.06

**d** = Wire Diameter (mm)    **Lo** = Spring Length (mm)    **De** = External Diameter (mm)    **Min./Max.** = pressure (bar)

Tab. 13.78

LA/MP "Max pressure"							
Pos.	Spring item code	Spring colour	d	Lo	De	Min.	Max.
1	64470115	Grey	2.8	42	34	0.14	0.179
2	64470116	Yellow	3.2	40	34	0.18	0.279
3	64470051	White	3.2	50	34	0.28	0.45

**d** = Wire Diameter (mm)    **Lo** = Spring Length (mm)    **De** = External Diameter (mm)    **Min./Max.** = pressure (bar)

Tab. 13.79

LA/MP "Min pressure"							
Pos.	Spring item code	Spring colour	d	Lo	De	Min.	Max.
1	64470024	White	1.3	45	15	0.01	0.059
2	64470038	Yellow	2	40	15	0.06	0.24

**d** = Wire Diameter (mm)    **Lo** = Spring Length (mm)    **De** = External Diameter (mm)    **Min./Max.** = pressure (bar)

Tab. 13.80

LA/TR "Max pressure"							
Pos.	Spring item code	Spring colour	d	Lo	De	Min.	Max.
1	64470116	Yellow	3.2	40	34	0.25	0.549
2	64470051	White	3.2	50	34	0.55	0.849
3	64470057	Blue	3.5	50	34	0.85	1.399
4	64470058	Orange	4	50	34	1.4	2.499
5	64470059	Light blue	4.5	50	34	2.5	3.999
6	64470060	Black	5	48	34	4	5.5

**d** = Wire Diameter (mm)    **Lo** = Spring Length (mm)    **De** = External Diameter (mm)    **Min./Max.** = pressure (bar)

Tab. 13.81

LA/TR "Min pressure"							
Pos.	Spring item code	Spring colour	d	Lo	De	Min.	Max.
1	64470038	Yellow	2	40	34	0.1	0.499
2	64470045	Brown	2.4	41	34	0.5	0.999
3	64470046	Blue	3	40	34	1	1.999
4	64470149	Black	3.2	43	34	2	3.5

**d** = Wire Diameter (mm)    **Lo** = Spring Length (mm)    **De** = External Diameter (mm)    **Min./Max.** = pressure (bar)

Tab. 13.82

LA/BP (LP) "Max pressure"							
Pos.	Spring item code	Spring colour	d	Lo	De	Min.	Max.
1	64470112	Red	2.2	44	34	0.02	0.49
2	64470115	Grey	2.8	42	34	0.05	0.18

**d** = Wire Diameter (mm)    **Lo** = Spring Length (mm)    **De** = External Diameter (mm)    **Min./Max.** = pressure (bar)

Tab. 13.83

LA/BP (LP) "Min pressure"							
Pos.	Spring item code	Spring colour	d	Lo	De	Min.	Max.
1	64470024	White	1.3	45	15	0.006	0.06

**d** = Wire Diameter (mm)    **Lo** = Spring Length (mm)    **De** = External Diameter (mm)    **Min./Max.** = pressure (bar)

Tab. 13.84

## 13.2 - FLOW RATE TABLES

Dival 700 1/4 BP 1" (AC = 10 according to EN 334)					
Inlet pressure	Outlet pressure				
	0,02 bar	0,05 bar	0.1 bar	0.2 bar	0,34 bar
bar	Sm <sup>3</sup> /h	Sm <sup>3</sup> /h	Sm <sup>3</sup> /h	Sm <sup>3</sup> /h	Sm <sup>3</sup> /h
0.5	30	30	30	30	25
1.0	45	45	45	43	40
2.0	73	73	73	73	72
3.0	100	100	95	100	100
4.5	129	137	139	139	139
6.0	149	179	179	179	179
8.5	83	98	122	165	226

**C<sub>g</sub> = 50 | K<sub>1</sub> = 98**

Tab. 13.85

Dival 700 1/4 BP 1' ½ (AC = 10 according to EN 334)					
Inlet pressure	Outlet pressure				
	0,02 bar	0,05 bar	0.1 bar	0.2 bar	0,34 bar
bar	Sm <sup>3</sup> /h	Sm <sup>3</sup> /h	Sm <sup>3</sup> /h	Sm <sup>3</sup> /h	Sm <sup>3</sup> /h
0.5	30	30	30	28	25
1.0	45	45	45	43	40
2.0	73	73	73	73	72
3.0	100	100	100	100	100
4.5	139	139	139	139	139
6.0	179	179	179	175	162
8.5	226	226	226	225	225

**C<sub>g</sub> = 50 | K<sub>1</sub> = 119**

Tab. 13.86

Dival 700 1/4 BP 2" (AC = 10 according to EN 334)					
Inlet pressure	Outlet pressure				
	0,02 bar	0,05 bar	0.1 bar	0.2 bar	0,34 bar
bar	Sm <sup>3</sup> /h	Sm <sup>3</sup> /h	Sm <sup>3</sup> /h	Sm <sup>3</sup> /h	Sm <sup>3</sup> /h
0.5	30	30	30	32	35
1.0	45	57	45	43	40
2.0	73	73	73	73	72
3.0	100	100	100	100	100
4.5	139	139	139	139	139
6.0	179	179	179	179	179
8.5	226	226	226	225	226

**C<sub>g</sub> = 50 | K<sub>1</sub> = 115**

Tab. 13.87

**Dival 700 3/8 BP 1" (AC = 10 according to EN 334)**

Inlet pressure	Outlet pressure				
	0,02 bar	0,05 bar	0.1 bar	0.2 bar	0,34 bar
bar	Sm <sup>3</sup> /h	Sm <sup>3</sup> /h	Sm <sup>3</sup> /h	Sm <sup>3</sup> /h	Sm <sup>3</sup> /h
0.5	55	55	60	60	51
1.0	90	90	90	97	104
2.0	136	118	128	136	135
3.0	140	130	149	157	178
4.5	139	179	189	227	249
6.0	149	199	189	253	318
8.5	83	128	198	312	412

**C<sub>g</sub> = 92 | K<sub>1</sub> = 91**
*Tab. 13.88*
**Dival 700 3/8 BP 1" ½ (AC = 10 according to EN 334)**

Inlet pressure	Outlet pressure				
	0,02 bar	0,05 bar	0.1 bar	0.2 bar	0,34 bar
bar	Sm <sup>3</sup> /h	Sm <sup>3</sup> /h	Sm <sup>3</sup> /h	Sm <sup>3</sup> /h	Sm <sup>3</sup> /h
0.5	59	56	50	49	55
1.0	100	100	100	96	90
2.0	148	148	147	147	146
3.0	199	199	199	199	199
4.5	294	308	284	290	275
6.0	355	374	378	378	378
8.5	377	414	471	471	471

**C<sub>g</sub> = 107 | K<sub>1</sub> = 101**
*Tab. 13.89*
**Dival 700 3/8 BP 2" (AC = 10 according to EN 334)**

Inlet pressure	Outlet pressure				
	0,02 bar	0,05 bar	0.1 bar	0.2 bar	0,34 bar
bar	Sm <sup>3</sup> /h	Sm <sup>3</sup> /h	Sm <sup>3</sup> /h	Sm <sup>3</sup> /h	Sm <sup>3</sup> /h
0.5	90	89	60	64	55
1.0	100	100	100	96	90
2.0	148	148	148	147	146
3.0	219	219	219	219	219
4.5	294	303	284	297	275
6.0	378	412	378	378	378
8.5	471	473	471	471	471

**C<sub>g</sub> = 107 | K<sub>1</sub> = 101**
*Tab. 13.90*



Dival 700 1/2 BP 1" (AC = 10 according to EN 334)					
Inlet pressure	Outlet pressure				
	0,02 bar	0,05 bar	0.1 bar	0.2 bar	0,34 bar
bar	Sm <sup>3</sup> /h	Sm <sup>3</sup> /h	Sm <sup>3</sup> /h	Sm <sup>3</sup> /h	Sm <sup>3</sup> /h
0.5	95	80	85	85	72
1.0	105	110	120	130	139
2.0	172	156	167	179	237
3.0	189	164	179	187	323
4.5	199	204	206	301	446
6.0	199	199	229	327	538
8.5	198	198	228	356	580

**C<sub>g</sub> = 161 | K<sub>1</sub> = 97**

Tab. 13.91

Dival 700 1/2 BP 1" ½ (AC = 10 according to EN 334)					
Inlet pressure	Outlet pressure				
	0,02 bar	0,05 bar	0.1 bar	0.2 bar	0,34 bar
bar	Sm <sup>3</sup> /h	Sm <sup>3</sup> /h	Sm <sup>3</sup> /h	Sm <sup>3</sup> /h	Sm <sup>3</sup> /h
0.5	90	83	71	66	75
1.0	165	165	165	163	133
2.0	242	239	239	244	236
3.0	269	324	329	340	260
4.5	323	367	428	456	432
6.0	397	469	507	540	547
8.5	425	494	543	599	729

**C<sub>g</sub> = 141 | K<sub>1</sub> = 94**

Tab. 13.92

Dival 700 1/2 BP 2" (AC = 10 according to EN 334)					
Inlet pressure	Outlet pressure				
	0,02 bar	0,05 bar	0.1 bar	0.2 bar	0,34 bar
bar	Sm <sup>3</sup> /h	Sm <sup>3</sup> /h	Sm <sup>3</sup> /h	Sm <sup>3</sup> /h	Sm <sup>3</sup> /h
0.5	128	125	105	80	78
1.0	170	165	165	163	133
2.0	244	244	244	244	236
3.0	269	324	329	311	249
4.5	323	378	435	459	432
6.0	397	457	507	540	547
8.5	528	532	543	611	729

**C<sub>g</sub> = 151 | K<sub>1</sub> = 93**

Tab. 13.93

**Dival 700 3/4 BP 1" (AC = 10 according to EN 334)**

Inlet pressure	Outlet pressure				
	0,02 bar	0,05 bar	0.1 bar	0.2 bar	0,34 bar
bar	Sm <sup>3</sup> /h	Sm <sup>3</sup> /h	Sm <sup>3</sup> /h	Sm <sup>3</sup> /h	Sm <sup>3</sup> /h
0.5	150	110	110	124	112
1.0	200	130	140	170	205
2.0	247	220	183	230	287
2.5	258	248	196	259	317
3.0	269	269	209	288	346
4.0	299	269	219	331	423
5,0	318	269	234	336	451

**C<sub>g</sub> = 253 | K<sub>1</sub> = 93**
*Tab. 13.94*
**Dival 700 3/4 BP 1" ½ (AC = 10 according to EN 334)**

Inlet pressure	Outlet pressure				
	0,02 bar	0,05 bar	0.1 bar	0.2 bar	0,34 bar
bar	Sm <sup>3</sup> /h	Sm <sup>3</sup> /h	Sm <sup>3</sup> /h	Sm <sup>3</sup> /h	Sm <sup>3</sup> /h
0.5	141	134	122	118	136
1.0	181	201	234	236	209
2.0	265	294	342	364	340
2.5	312	346	390	427	395
3.0	360	400	439	490	449
4.0	352	424	508	604	718
5,0	423	509	652	734	863

**C<sub>g</sub> = 158 | K<sub>1</sub> = 96**
*Tab. 13.95*
**Dival 700 3/4 BP 2" (AC = 10 according to EN 334)**

Inlet pressure	Outlet pressure				
	0,02 bar	0,05 bar	0.1 bar	0.2 bar	0,34 bar
bar	Sm <sup>3</sup> /h	Sm <sup>3</sup> /h	Sm <sup>3</sup> /h	Sm <sup>3</sup> /h	Sm <sup>3</sup> /h
0.5	218	205	170	147	136
1.0	290	270	275	251	209
2.0	325	318	331	319	274
2.5	417	389	399	385	340
3.0	462	468	423	434	395
4.0	498	548	439	479	449
5,0	520	552	465	535	561

**C<sub>g</sub> = 171 | K<sub>1</sub> = 89**
*Tab. 13.96*

Dival 700 1 BP 1" ½ (AC = 10 according to EN 334)					
Inlet pressure	Outlet pressure				
	0,05 bar	0.1 bar	0.2 bar	0,3 bar	0,34 bar
bar	Sm <sup>3</sup> /h	Sm <sup>3</sup> /h	Sm <sup>3</sup> /h	Sm <sup>3</sup> /h	Sm <sup>3</sup> /h
0.5	232	250	228	210	210
1.0	309	340	346	340	340
2.0	383	427	430	417	423
2.5	452	499	507	489	521
3.0	502	527	532	522	541
4.0	548	548	548	548	548
5,0	592	592	592	592	608

**C<sub>g</sub> = 332 | K<sub>1</sub> = 102**

Tab. 13.97

Dival 700 1 BP 2" (AC = 10 according to EN 334)					
Inlet pressure	Outlet pressure				
	0,05 bar	0.1 bar	0.2 bar	0,3 bar	0,34 bar
bar	Sm <sup>3</sup> /h	Sm <sup>3</sup> /h	Sm <sup>3</sup> /h	Sm <sup>3</sup> /h	Sm <sup>3</sup> /h
0.5	235	250	228	210	210
1.0	315	340	346	340	340
2.0	405	427	430	417	423
2.5	465	499	507	489	521
3.0	531	550	555	545	564
4.0	598	598	598	598	598
5,0	642	642	642	642	642

**C<sub>g</sub> = 346 | K<sub>1</sub> = 86**

Tab. 13.98

Dival 700 1 1/4 BP 1" ½ (AC = 10 according to EN 334)					
Inlet pressure	Outlet pressure				
	0,05 bar	0.1 bar	0.2 bar	0,3 bar	0,34 bar
bar	Sm <sup>3</sup> /h	Sm <sup>3</sup> /h	Sm <sup>3</sup> /h	Sm <sup>3</sup> /h	Sm <sup>3</sup> /h
0.5	158	189	242	258	249
1.0	263	286	314	325	322
2.0	290	320	350	375	400
2.5	337	371	402	439	478
3.0	365	401	433	476	529
4.0	404	442	476	525	604
5,0	430	469	504	558	654

**C<sub>g</sub> = 393 | K<sub>1</sub> = 91**

Tab. 13.99

**Dival 700 1 1/4 BP 2" (AC = 10 according to EN 334)**

Inlet pressure	Outlet pressure				
	0,05 bar	0.1 bar	0.2 bar	0,3 bar	0,34 bar
bar	Sm <sup>3</sup> /h	Sm <sup>3</sup> /h	Sm <sup>3</sup> /h	Sm <sup>3</sup> /h	Sm <sup>3</sup> /h
0.5	250	265	258	240	249
1.0	310	333	325	313	322
2.0	330	350	375	400	400
2.5	373	397	439	478	478
3.0	401	427	476	520	529
4.0	442	473	525	572	604
5,0	469	503	558	607	654

**C<sub>g</sub> = 440 | K<sub>1</sub> = 86**
*Tab. 13.100*
**Dival 700 1/4 TR 1" (AC = 10 according to EN 334)**

Inlet pressure	Outlet pressure				
	0,03 bar	0,05 bar	0,07 bar	0.1 bar	0,13 bar
bar	Sm <sup>3</sup> /h	Sm <sup>3</sup> /h	Sm <sup>3</sup> /h	Sm <sup>3</sup> /h	Sm <sup>3</sup> /h
0.5	30	-	-	-	-
1.0	40	40	32	-	-
2.0	73	72	65	59	56
3.0	100	100	100	100	100
4.5	139	139	139	139	140
6.0	179	179	179	179	179
8.5	226	226	226	226	226

**C<sub>g</sub> = 40 | K<sub>1</sub> = 98**
*Tab. 13.101*
**Dival 700 1/4 TR 1' 1/2 (AC = 10 according to EN 334)**

Inlet pressure	Outlet pressure				
	0,03 bar	0,05 bar	0,07 bar	0.1 bar	0,13 bar
bar	Sm <sup>3</sup> /h	Sm <sup>3</sup> /h	Sm <sup>3</sup> /h	Sm <sup>3</sup> /h	Sm <sup>3</sup> /h
0.5	26	-	-	-	-
1.0	40	40	32	-	-
2.0	73	72	65	59	55
3.0	100	100	100	100	100
4.5	139	139	139	139	140
6.0	169	179	179	179	179
8.5	225	226	226	226	226

**C<sub>g</sub> = 50 | K<sub>1</sub> = 119**
*Tab. 13.102*

<b>Dival 700 1/4 TR 2" (AC = 10 according to EN 334)</b>					
<b>Inlet pressure</b>	<b>Outlet pressure</b>				
	0,03 bar	0,05 bar	0,07 bar	0.1 bar	0,13 bar
bar	Sm <sup>3</sup> /h	Sm <sup>3</sup> /h	Sm <sup>3</sup> /h	Sm <sup>3</sup> /h	Sm <sup>3</sup> /h
0.5	34	-	-	-	-
1.0	40	40	32	-	-
2.0	73	72	65	59	57
3.0	100	100	100	100	100
4.5	139	139	139	139	140
6.0	179	179	179	179	179
8.5	225	226	226	226	226

**C<sub>g</sub> = 50 | K<sub>1</sub> = 115**

*Tab. 13.103*

<b>Dival 700 3/8 TR 1" (AC = 10 according to EN 334)</b>					
<b>Inlet pressure</b>	<b>Outlet pressure</b>				
	0,03 bar	0,05 bar	0,07 bar	0.1 bar	0,13 bar
bar	Sm <sup>3</sup> /h	Sm <sup>3</sup> /h	Sm <sup>3</sup> /h	Sm <sup>3</sup> /h	Sm <sup>3</sup> /h
0.5	60	-	-	-	-
1.0	100	95	91	-	-
2.0	136	135	120	100	94
3.0	169	179	180	180	180
4.5	249	249	249	249	249
6.0	318	318	318	318	318
8.5	412	412	412	412	412

**C<sub>g</sub> = 93 | K<sub>1</sub> = 91**

*Tab. 13.104*

<b>Dival 700 3/8 TR 1" ½ (AC = 10 according to EN 334)</b>					
<b>Inlet pressure</b>	<b>Outlet pressure</b>				
	0,03 bar	0,05 bar	0,07 bar	0.1 bar	0,13 bar
bar	Sm <sup>3</sup> /h	Sm <sup>3</sup> /h	Sm <sup>3</sup> /h	Sm <sup>3</sup> /h	Sm <sup>3</sup> /h
0.5	55	-	-	-	-
1.0	90	80	64	-	-
2.0	147	145	144	135	131
3.0	199	199	199	200	200
4.5	284	279	291	294	294
6.0	378	378	378	378	378
8.5	471	471	471	471	471

**C<sub>g</sub> = 107 | K<sub>1</sub> = 101**

*Tab. 13.105*

**Dival 700 3/8 TR 2" (AC = 10 according to EN 334)**

Inlet pressure	Outlet pressure				
	0,03 bar	0,05 bar	0,07 bar	0.1 bar	0,13 bar
bar	Sm <sup>3</sup> /h	Sm <sup>3</sup> /h	Sm <sup>3</sup> /h	Sm <sup>3</sup> /h	Sm <sup>3</sup> /h
0.5	55	-	-	-	-
1.0	90	80	64	-	-
2.0	147	145	144	135	131
3.0	219	219	219	219	220
4.5	284	279	291	294	294
6.0	378	378	378	378	378
8.5	471	471	471	471	471

**C<sub>g</sub> = 109 | K<sub>1</sub> = 104**
*Tab. 13.106*
**Dival 700 1/2 TR 1" (AC = 10 according to EN 334)**

Inlet pressure	Outlet pressure				
	0,03 bar	0,05 bar	0,07 bar	0.1 bar	0,13 bar
bar	Sm <sup>3</sup> /h	Sm <sup>3</sup> /h	Sm <sup>3</sup> /h	Sm <sup>3</sup> /h	Sm <sup>3</sup> /h
0.5	85	-	-	-	-
1.0	130	135	127	-	-
2.0	179	240	233	219	208
3.0	199	319	323	337	339
4.5	435	473	493	523	528
6.0	471	596	636	688	696
8.5	479	737	814	914	931

**C<sub>g</sub> = 180 | K<sub>1</sub> = 97**
*Tab. 13.107*
**Dival 700 1/2 TR 1' ½ (AC = 10 according to EN 334)**

Inlet pressure	Outlet pressure				
	0,03 bar	0,05 bar	0,07 bar	0.1 bar	0,13 bar
bar	Sm <sup>3</sup> /h	Sm <sup>3</sup> /h	Sm <sup>3</sup> /h	Sm <sup>3</sup> /h	Sm <sup>3</sup> /h
0.5	72	-	-	-	-
1.0	160	115	103	-	-
2.0	244	184	206	240	238
3.0	349	319	343	349	349
4.5	428	466	492	498	498
6.0	547	616	640	647	647
8.5	687	785	786	787	787

**C<sub>g</sub> = 170 | K<sub>1</sub> = 94**
*Tab. 13.108*

<b>Dival 700 1/2 TR 2" (AC = 10 according to EN 334)</b>					
<b>Inlet pressure</b>	<b>Outlet pressure</b>				
	0,03 bar	0,05 bar	0,07 bar	0.1 bar	0,13 bar
bar	Sm <sup>3</sup> /h	Sm <sup>3</sup> /h	Sm <sup>3</sup> /h	Sm <sup>3</sup> /h	Sm <sup>3</sup> /h
0.5	73	-	-	-	-
1.0	160	115	103	-	-
2.0	244	179	205	195	187
3.0	249	319	343	349	349
4.5	428	488	496	498	498
6.0	547	636	644	647	647
8.5	687	786	786	787	787

**C<sub>g</sub> = 179 | K<sub>1</sub> = 93**

*Tab. 13.109*

<b>Dival 700 3/4 TR 1" (AC = 10 according to EN 334)</b>					
<b>Inlet pressure</b>	<b>Outlet pressure</b>				
	0,03 bar	0,05 bar	0,07 bar	0.1 bar	0,13 bar
bar	Sm <sup>3</sup> /h	Sm <sup>3</sup> /h	Sm <sup>3</sup> /h	Sm <sup>3</sup> /h	Sm <sup>3</sup> /h
0.5	130	-	-	-	-
1.0	170	220	204	-	-
2.0	230	330	338	298	279
2.5	236	376	373	350	346
3.0	239	419	403	399	399
4.0	464	498	498	498	498
5,0	478	597	597	680	697

**C<sub>g</sub> = 317 | K<sub>1</sub> = 93**

*Tab. 13.110*

<b>Dival 700 3/4 TR 1' 1/2 (AC = 10 according to EN 334)</b>					
<b>Inlet pressure</b>	<b>Outlet pressure</b>				
	0,03 bar	0,05 bar	0,07 bar	0.1 bar	0,13 bar
bar	Sm <sup>3</sup> /h	Sm <sup>3</sup> /h	Sm <sup>3</sup> /h	Sm <sup>3</sup> /h	Sm <sup>3</sup> /h
0.5	125	-	-	-	-
1.0	200	240	200	-	-
2.0	339	389	395	361	344
2.5	395	468	491	479	476
3.0	449	548	588	599	599
4.0	647	797	797	781	778
5,0	796	896	936	946	946

**C<sub>g</sub> = 307 | K<sub>1</sub> = 91**

*Tab. 13.111*

**Dival 700 3/4 TR 2" (AC = 10 according to EN 334)**

Inlet pressure	Outlet pressure				
	0,03 bar	0,05 bar	0,07 bar	0.1 bar	0,13 bar
bar	Sm <sup>3</sup> /h	Sm <sup>3</sup> /h	Sm <sup>3</sup> /h	Sm <sup>3</sup> /h	Sm <sup>3</sup> /h
0.5	125	-	-	-	-
1.0	200	240	200	-	-
2.0	339	389	395	454	448
2.5	395	468	510	582	594
3.0	449	548	628	711	724
4.0	647	797	797	797	798
5,0	796	896	936	946	946

**C<sub>g</sub> = 320 | K<sub>1</sub> = 89**
*Tab. 13.112*
**Dival 700 1 TR 1" ½ (AC = 10 according to EN 334)**

Inlet pressure	Outlet pressure				
	0,03 bar	0,05 bar	0,07 bar	0.1 bar	0,13 bar
bar	Sm <sup>3</sup> /h	Sm <sup>3</sup> /h	Sm <sup>3</sup> /h	Sm <sup>3</sup> /h	Sm <sup>3</sup> /h
0.5	210	-	-	-	-
1.0	340	330	266	-	-
1.5	417	426	422	359	282
2.0	489	534	547	507	486
2.5	522	549	576	560	556
3.0	548	548	588	599	599
3.4	592	681	721	709	705

**C<sub>g</sub> = 429 | K<sub>1</sub> = 85**
*Tab. 13.113*
**Dival 700 1 TR 2" (AC = 10 according to EN 334)**

Inlet pressure	Outlet pressure				
	0,03 bar	0,05 bar	0,07 bar	0.1 bar	0,13 bar
bar	Sm <sup>3</sup> /h	Sm <sup>3</sup> /h	Sm <sup>3</sup> /h	Sm <sup>3</sup> /h	Sm <sup>3</sup> /h
0.5	210	-	-	-	-
1.0	340	330	266	-	-
1.5	417	433	423	359	282
2.0	489	570	555	507	486
2.5	545	593	585	560	556
3.0	598	598	598	599	599
3.4	642	687	722	768	776

**C<sub>g</sub> = 447 | K<sub>1</sub> = 86**
*Tab. 13.114*



Dival 700 1 1/4 TR 1' 1/2 (AC = 10 according to EN 334)					
Inlet pressure	Outlet pressure				
	0,03 bar	0,05 bar	0,07 bar	0.1 bar	0,13 bar
bar	Sm <sup>3</sup> /h	Sm <sup>3</sup> /h	Sm <sup>3</sup> /h	Sm <sup>3</sup> /h	Sm <sup>3</sup> /h
0.5	240	-	-	-	-
0.8	313	317	0	-	-
1.0	400	350	326	-	-
1.3	478	429	398	363	-
1.5	520	489	463	457	347
1.8	572	589	577	574	499
2.0	607	655	652	652	633

**C<sub>g</sub> = 530 | K<sub>1</sub> = 85**

Tab. 13.115

Dival 700 1 1/4 TR 2" (AC = 10 according to EN 334)					
Inlet pressure	Outlet pressure				
	0,03 bar	0,05 bar	0,07 bar	0.1 bar	0,13 bar
bar	Sm <sup>3</sup> /h	Sm <sup>3</sup> /h	Sm <sup>3</sup> /h	Sm <sup>3</sup> /h	Sm <sup>3</sup> /h
0.5	240	-	-	-	-
0.8	313	317	263	-	-
1.0	400	350	326	-	-
1.3	478	429	398	365	-
1.5	520	489	463	459	349
1.8	572	589	577	575	499
2.0	607	655	652	652	633

**C<sub>g</sub> = 570 | K<sub>1</sub> = 86**

Tab. 13.116

TM0023ENG

