

Norval

Medium - Low Pressure Gas Regulator



TECHNICAL BROCHURE

Pietro Fiorentini S.p.A.

Via E.Fermi, 8/10 | 36057 Arcugnano, Italy | +39 0444 968 511
sales@fiorentini.com

The data are not binding. We reserve the right
to make changes without prior notice.

norval_technicalbrochure_ENG_revN

www.f Fiorentini.com

Who we are

We are a global organization that specializes in designing and manufacturing technologically advanced solutions for natural gas treatment, transmission and distribution systems.

We are the ideal partner for operators in the Oil & Gas sector, with a business solutions that span the whole natural gas chain.

We are constantly evolving to meet our customers' highest expectations in terms of quality and reliability.

Our aim is to be a step ahead of the competition, with customized technologies and an after-sale service program undertaken with the highest level of professionalism.



Pietro Fiorentini advantages



Localised technical support



Experience since 1940



Operating in over 100 countries



Area of Application

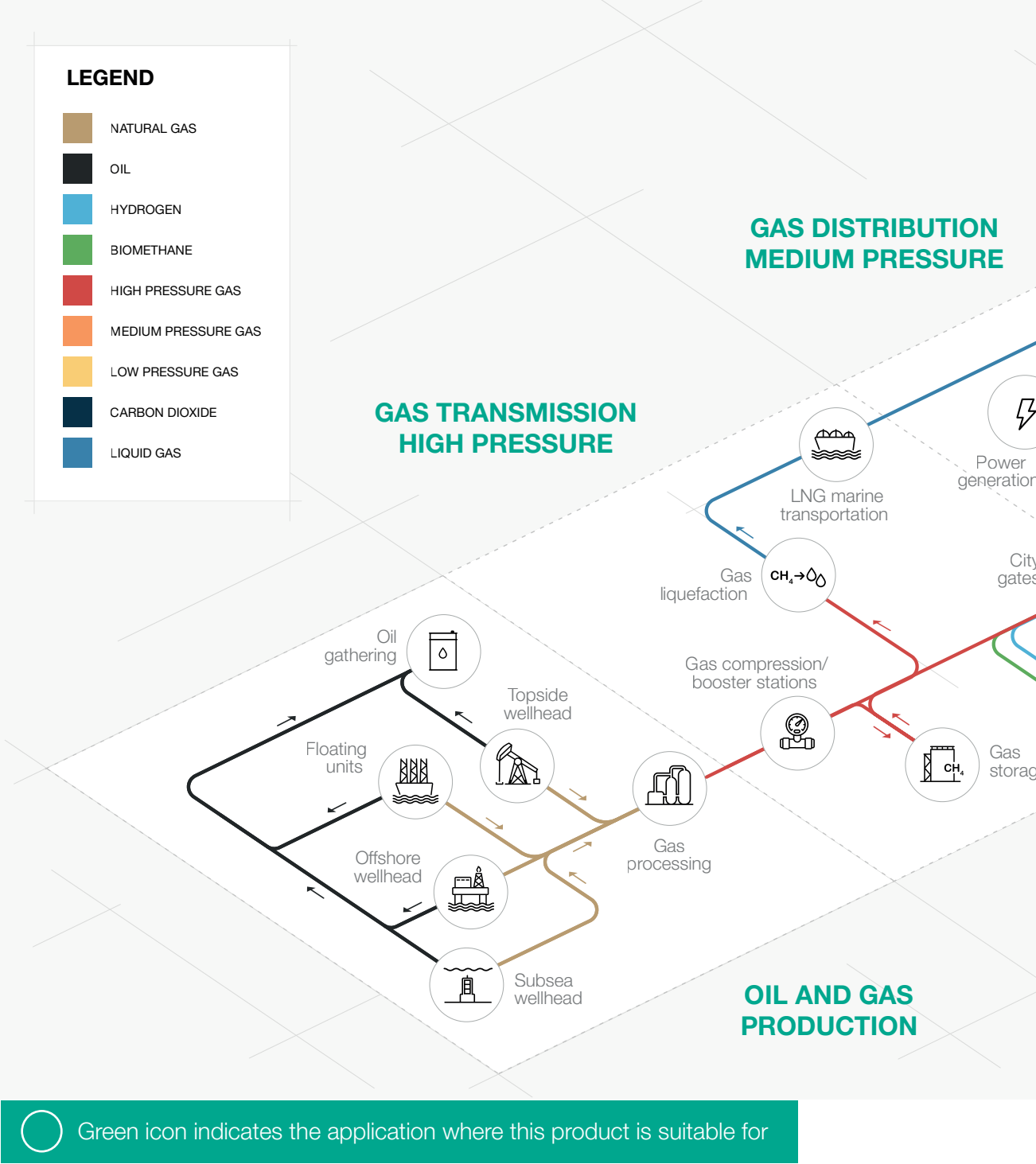

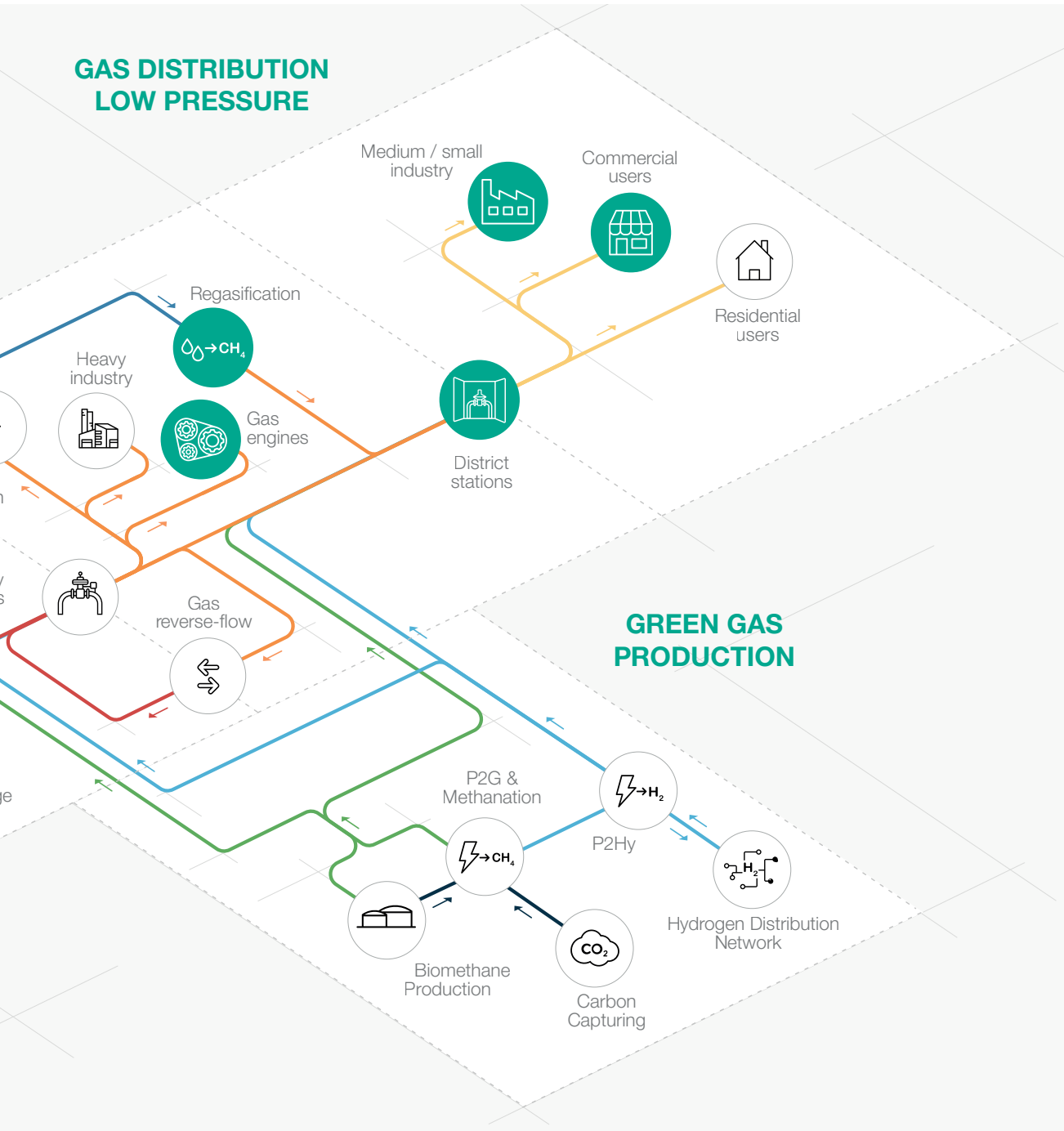

Figure 1 Area of Application Map



Introduction

The **Norval** by Pietro Fiorentini is a **direct-operated** gas pressure regulator.

Suitable for use with previously filtered gaseous fluids, it is mainly used for medium and low pressure natural gas distribution networks.

It is classified as **Fail Open** according to the European Standard EN 334.

The Norval is **Hydrogen Ready** for NG-H2 blending.

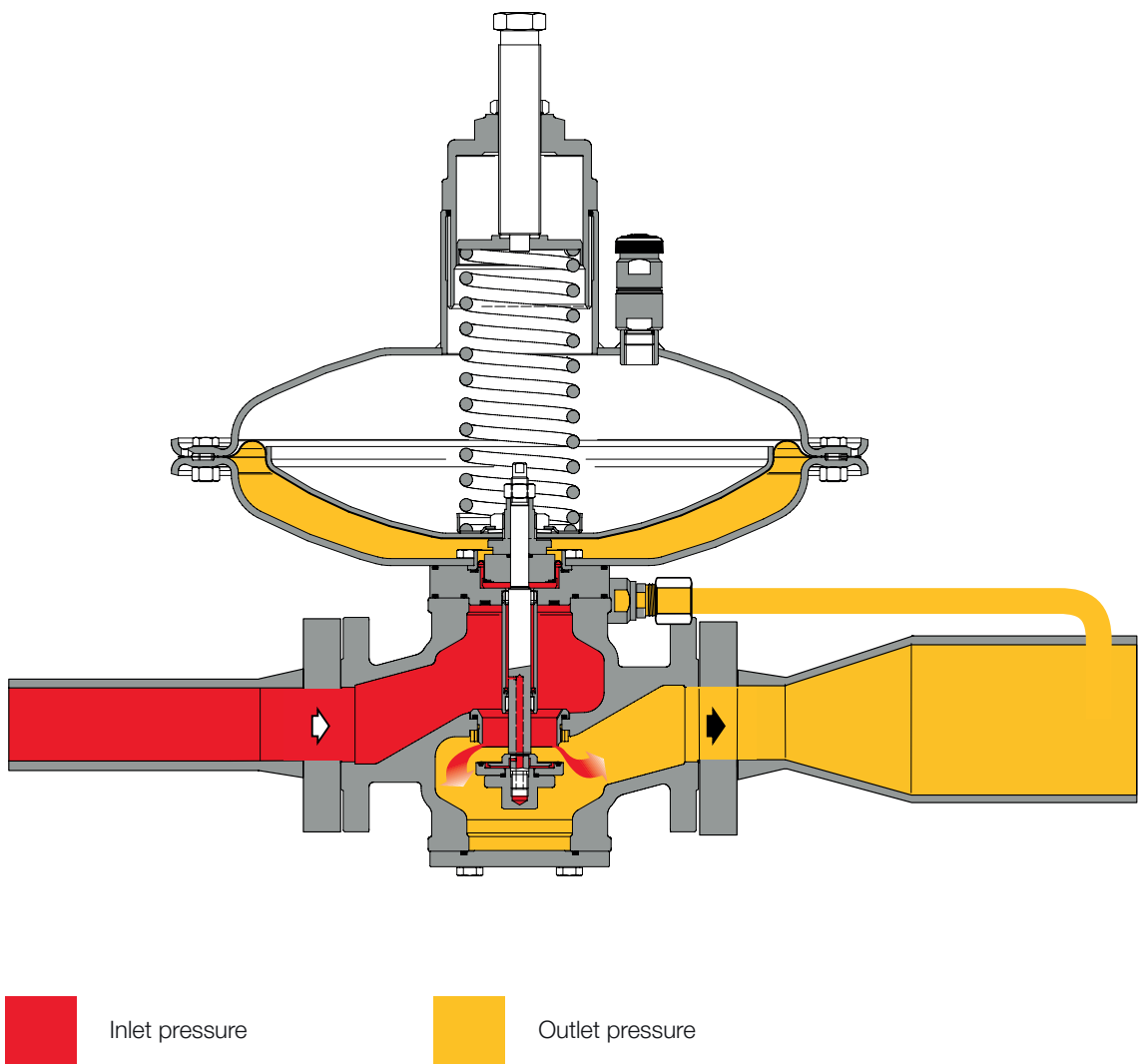

Figure 2 Norval

Features and Calibration ranges

The **Norval** is a **direct-operated** device for medium pressure and low pressure with a unique **dynamic balancing system** which ensures an **outstanding turn down ratio** combined with an extremely **accurate outlet pressure control**.

A balanced pressure regulator it is a pressure regulator where delivery pressure accuracy it is not affected by the fluctuation of the inlet pressure and flow during its operation. Therefore, a balance pressure regulator can have a single orifice for all pressure and flow operating conditions.

This regulator is suitable for use with previously filtered, non corrosive gases in distribution networks as well as high load industrial applications.

It is a **truly top entry design** which allows an **easy maintenance** of parts directly in the field **without removing the body from the pipework**.

The modular design of the Norval pressure regulators allows to retrofit either slam shut valve SN, ER monitor attachment or silencer.

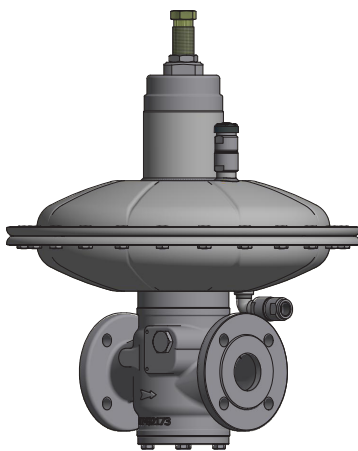

Figure 3 Norval

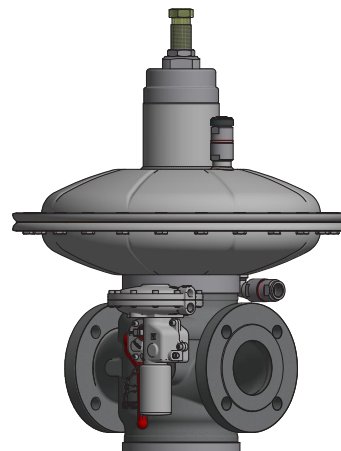









Figure 4 Norval with SN slam shut valve



Norval competitive advantages

- | | |
|---|--|
|  Compact and simple design |  Top Entry |
|  High accuracy |  Easy maintenance |
|  Fail Open plug and seat regulator |  In-built accessories |
|  Balanced type |  Biomethane compatible and 20% Hydrogen blending compatible. Higher blending available on request |

Features

Features	Values
Design pressure* (PS ¹ / DP ²)	up to 1.89 MPa up to 18.9 barg
Ambient temperature* (TS ¹)**	from -20 °C to +60 °C from -4 °F to +140 °F
Inlet gas temperature* ^{***}	from -20 °C to +60 °C from -4 °F to +140 °F
Inlet pressure (MAOP / p _{umax} ¹)	<ul style="list-style-type: none"> for DN up to 3": from 0.01 to 1.89 MPa from 0.1 to 18.9 barg for DN 4", 6" and 8": from 0.01 to 0.86 MPa from 0.1 to 8.6 barg
Range of downstream pressure (Wd ¹)	<ul style="list-style-type: none"> for DN up to 4": from 0.8 to 440 kPa from 8 mbarg to 4.4 barg for DN 6" and 8": from 1.2 to 180 kPa from 12 mbarg to 1.8 barg
Available accessories	SN Slam shut, silencer, ER monitor attachment
Minimum operating differential pressure (Δp _{min} ¹)	10 kPa 100 mbarg
Accuracy class (AC ¹)	up to 5 up to 1% absolute (depending on working conditions)
Lock-up pressure class (SG ¹)	up to 10 (depending on working conditions)
Nominal size (DN ^{1,2})	DN 25 1"; DN 40 1" 1/2; DN 50 2"; DN 65 2" 1/2; DN 80 3"; DN 100 4"; DN 150 6"; DN 200 8"
Connections	Class 150 RF according to ASME B16.5 and PN16 according to ISO 7005

(¹) according to EN334 standard

(²) according to ISO 23555-1 standard

(*) NOTE: Different functional features and/or extended temperature ranges may be available on request. Stated inlet gas temperature range is the maximum for which the equipment's full performance, including accuracy is guaranteed. Product may have a different pressure or temperature ranges according to the version and/or installed accessories.

(**) NOTE: Stated temperature range is the operating range for which the equipment's mechanical resistance and leakage rate are guaranteed. Some body materials, if multiple choices are available, may not be suitable for all the available versions shown.

(***) NOTE: Stated temperature range is the range for which the equipment's full performance, including accuracy and lock-up are guaranteed. Some body materials, if multiple choices are available, may not be suitable for all the available versions shown.

Table 1 Features

Materials and Approvals

Part	Material
Body	Cast steel ASTM A 216 WCB (all DN). Spheroidal ductile iron GS 400 – 18 ISO 1083 DN 150 (6") included.
Cover	From diameter 375 mm to 630 mm die stamped carbon steel From diameter 658 mm to 817 mm alluminium
Seat	Stainless steel
Diaphragm	Rubberized canvas (performed by hot-pressing process).
O-rings	Nitrile rubber
Compression fittings	On request

NOTE: The materials indicated above refer to the standard models. Different materials can be provided according to specific needs.

Table 2 Materials

Construction Standards and Approvals

The **Norval** regulator is designed according to the European standard EN 334.

The regulator reacts in opening (Fail Open) according to EN 334.

The product is certified according to European Directive 2014/68/EU (PED).

Leakage class: bubble tight, better than class VIII according to ANSI/FCI 70-3.



EN 334



PED-CE



Design pressure by version

Design pressure (PS according to EN334)				
Version	Body		Slam shut	
	MPa	barg	MPa	barg
PN16 Steel body	1.60	16	1.89	18.9
PN16 cast iron body	1.60	16	1.89	18.9
#150 steel body	1.89	18.9	1.89	18.9
#150 ductile iron body	1.70	17	1.89	18.9

Table 3 Design pressure for body and slam shut

Design pressure (PS according to EN334)												
Parts	Control head											
	375TR		375		495		630		658		817	
	MPa	barg	MPa	barg	MPa	barg	MPa	barg	MPa	barg	MPa	barg
Cover	1.60	16	1.60	16	1.60	16	1.00	10	0.10	1	0.10	1
Diaphragm for bodies DN 1" - 2"	0.90	9	0.55	5.5	0.03	0.3	-	-	-	-	-	-
Diaphragm for bodies DN 2"1/2 - 4"	0.90	9	0.55	5.5	0.11	1.1	0.03	0.3	-	-	-	-
Diaphragm for bodies DN 6" - 8"	-	-	-	-	0.37	3.75	0.15	1.5	0.10	1	0.03	0.3
Max Diaphragm Δp for bodies DN 1" - 2"	0.60	6	0.15	1.5	0.02	0.2	-	-	-	-	-	-
Max Diaphragm Δp for bodies DN 2"1/2 - 4"	0.60	6	0.37	3.75	0.07	0.75	0.02	0.2	-	-	-	-
Max Diaphragm Δp for bodies DN 6" - 8"	-	-	-	-	0.25	2.5	0.10	1	0.06	0.65	0.02	0.2

Table 4 Design pressure for regulator's parts

Maximum allowable operating pressure

MAOP Maximum Allowable Operating Pressure (p_{umax} according to EN334)													
Version	Control head												
	375TR		375		495		630		658		817		
	MPa	barg	MPa	barg	MPa	barg	MPa	barg	MPa	barg	MPa	barg	
WITHOUT CE MARKING	PN16 loose regulator DN < 4" (all body materials)	1.60	16	1.60	16	1.60	16	1.60	16	-	-	-	-
	#150 steel body loose regulator DN < 4"	1.89	18.9	1.89	18.9	1.89	18.9	1.89	18.9	-	-	-	-
	#150 ductile iron body loose regulator DN < 4"	1.70	17	1.70	17	1.70	17	1.70	17	-	-	-	-
	PN16/#150 regulator DN < 4" (all body materials) + SSV	1.89	18.9	1.89	18.9	1.89	18.9	1.89	18.9	-	-	-	-
	PN16/#150 regulator DN ≥ 4" (all body materials)	0.80	8	0.80	8	0.80	8	0.80	8	0.80	8	0.80	8
	PN16/#150 regulator DN ≥ 4" (all body materials) + SSV	0.80	8	0.80	8	0.80	8	0.80	8	0.80	8	0.80	8

Table 5 MAOP Maximum Allowable Operating Pressure without CE marking

MAOP Maximum Allowable Operating Pressure (p_{umax} according to EN334)													
Version		Control head											
		375TR		375		495		630		658		817	
		MPa	barg	MPa	barg	MPa	barg	MPa	barg	MPa	barg	MPa	barg
WITH CE MARKING	PN16/#150 loose regulator DN < 4" (all body materials)	1.60	16	1.60	16	1.60	16	1.00	10	-	-	-	-
	PN16/#150 loose regulator DN < 4" (all body materials) + SSV	1.60	16	1.60	16	1.60	16	1.00	10	-	-	-	-
	PN16/#150 loose regulator DN >=4" (all body materials)	0.80	8	0.80	8	0.80	8	0.80	8	0.10	1	0.10	1
	PN16/#150 loose regulator DN >=4" (all body materials) + SSV	0.80	8	0.80	8	0.80	8	0.80	8	0.80	8	0.80	8

Table 7 MAOP Maximum Allowable Operating Pressure with CE marking

Springs ranges and control heads

Control heads pressure ranges									
Size (DN)	[mm] inches	[mm] inches	[mm] inches	[mm] inches	[mm] inches	[mm] inches	[mm] inches	[mm] inches	Spring Table web link
mm	kPa mbarg	kPa mbarg	kPa mbarg	kPa mbarg	kPa mbarg	kPa mbarg	kPa mbarg	kPa mbarg	
d. 817	-	-	-	-	-	-	1.2 - 7.9 12 - 79	1.2 - 7.9 12 - 79	TT 891
d. 658	-	-	-	-	-	-	7.5 - 40.5 75 - 405	7.5 - 40.5 75 - 405	TT 891
d. 630	-	-	-	1.0 - 8.0 10 - 80	1.0 - 8.0 10 - 80	1.2 - 8.0 12 - 80	22 - 65 220 - 650	22 - 65 220 - 650	TT 891
d. 495	1.6 - 8.3 16 - 83	1.6 - 8.3 16 - 83	1.6 - 8.3 16 - 83	8 - 53 80 - 530	8 - 53 80 - 530	8 - 53 80 - 530	39 - 180 390 - 1800	39 - 180 390 - 1800	TT 891
d. 375	8 - 110 80 - 1100	8 - 110 80 - 1100	8 - 110 80 - 1100	47 - 280 470 - 2800	47 - 280 470 - 2800	47 - 280 470 - 2800	-	-	TT 891
d. 375/ TR	90 - 440 900 - 4400	90 - 440 900 - 4400	90 - 440 900 - 4400	90 - 440 900 - 4400	90 - 440 900 - 4400	90 - 440 900 - 4400	-	-	TT 891

Table 6 Settings table

General link to the calibration tables: [PRESS HERE](#) or use the QR code:





Accessories

For the pressure regulators:

- Position transmitter
- Silencer
- Slam shut valve
- Monitor attachment

In-line Monitor

The in-line monitor is generally installed upstream of the active regulator.

Although the function of the monitor regulator is different, the two regulators are virtually identical from the point of view of their mechanical components.

The only difference is that monitor is set at a higher pressure than active regulator.

The C_g coefficients of the worker regulator with an in-line monitor is the same, but during worker regulator sizing it shall be considered the differential pressure drop generated by the fully open in-line monitor. As a practice, to incorporate this effect a C_g reduction of 20% of the worker regulator can be applied.

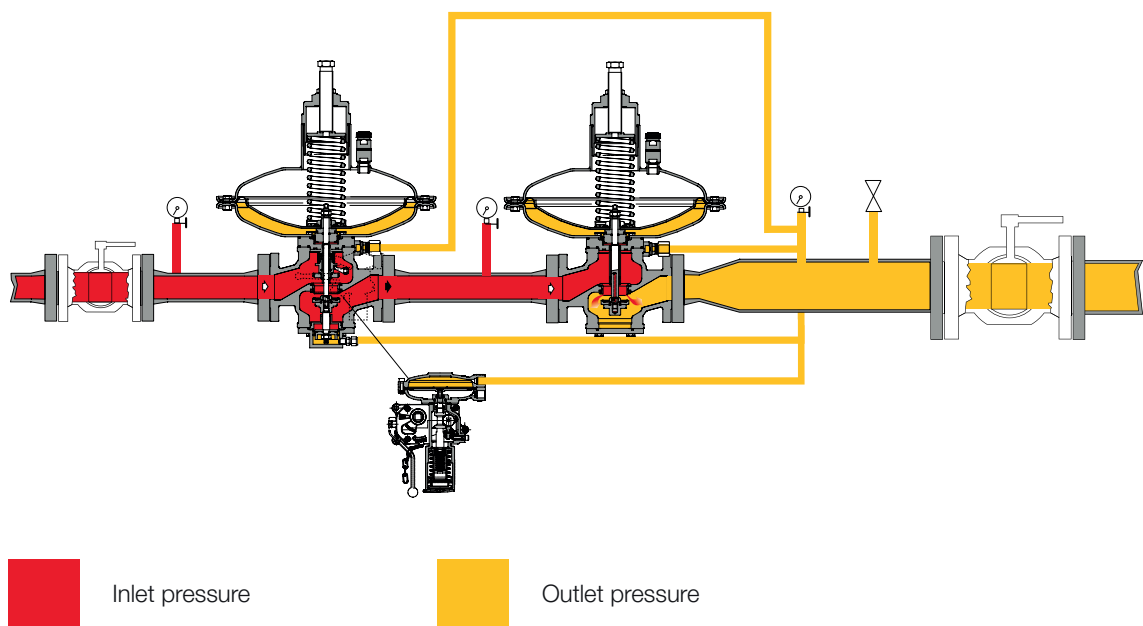

Figure 5 Norval inline monitor

ER Monitor attachment

This attachment is directly integrated into the body of the monitor regulator.

Typically inline monitor is normally in wide open position, therefore on fully balanced pressure regulator this specific condition made the regulator to be unbalanced.

The ER monitor attachment compensate this condition, balancing the monitor while in fully open position. **This attachment is strongly recommended to be installed on inline monitor.**

Another great advantage offered by the ER monitor attachment is that **it can be installed at any time**, even on an existing regulator to convert it from and active to an inline monitor.



Balanced type

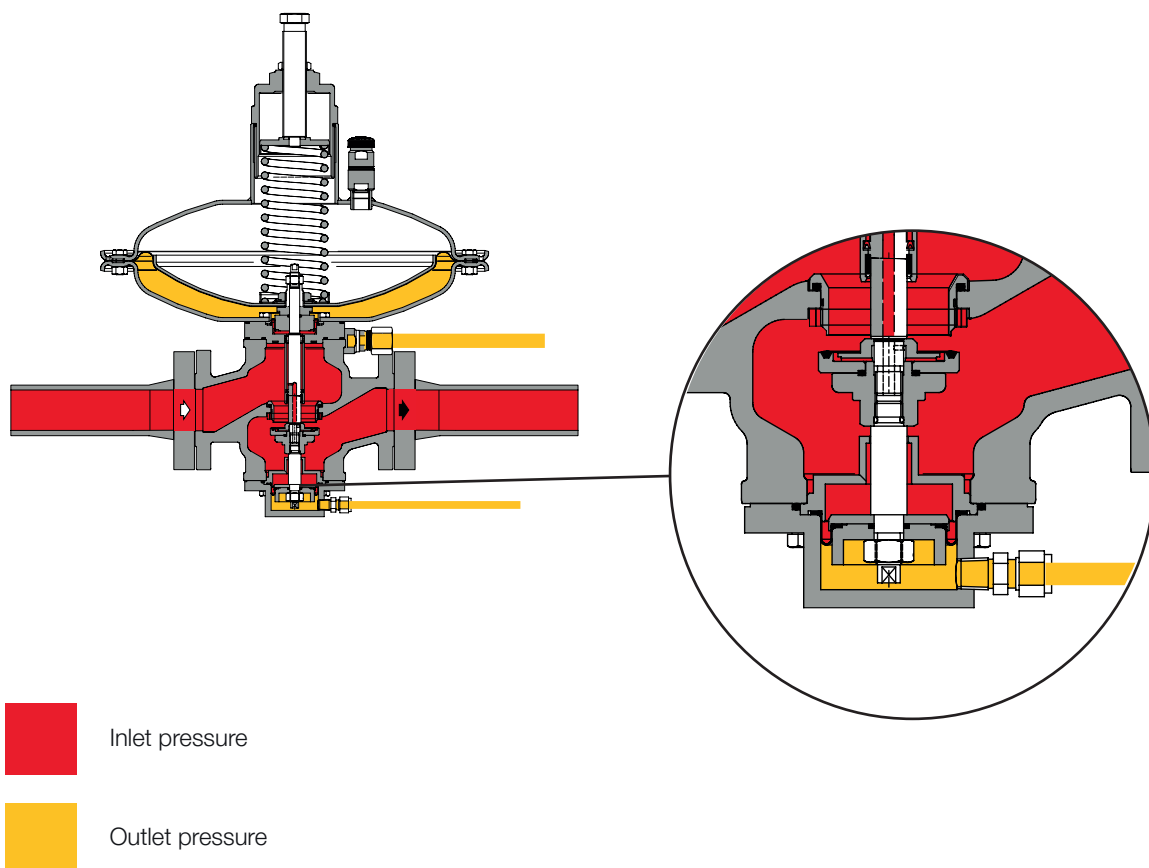

Figure 6 Norval with ER attachment



Silencer

Whenever certain noise limit is desired, an additional silencer allows to considerably reduce the noise level (dBA).

The Norval pressure regulator can be supplied with an **incorporated silencer** in either the standard version or version with incorporated slam shut or monitor regulator.

The high efficiency rely to the fact that noise absorption takes place at the same point where the noise is generated, thus preventing its propagation.

With the built-in silencer, the Cg valve coefficient is 5% lower than the corresponding version without.

Given the modular arrangement of the regulator, the silencer may be retrofitted to both standard Norval version as well as those with incorporated slam shut or monitor, **without the need to modify the main piping.**

Pressure reduction and control operate the same manner as standard version.

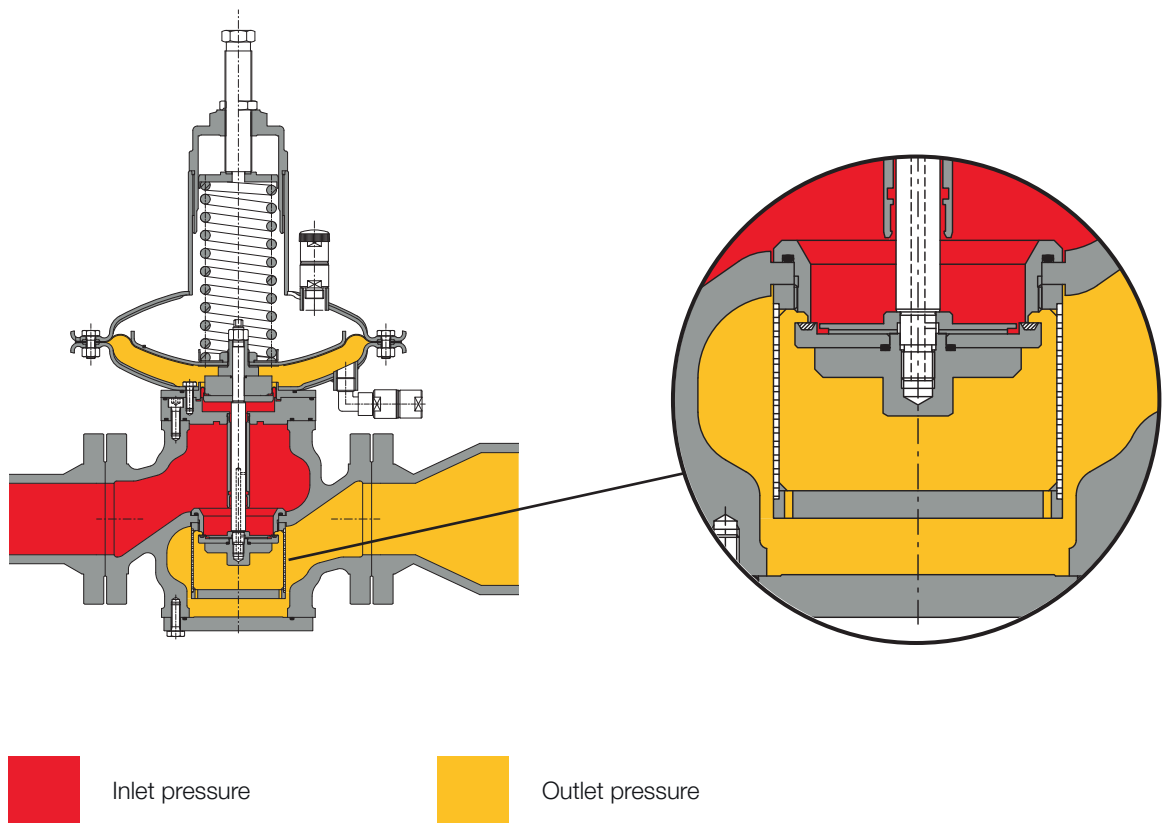

Figure 7 Norval with silencer









Slam Shut SN

The Norval pressure regulator offers the possibility of installing an **incorporated slam shut valve** SN and this can be done either during the manufacturing process or be retrofitted in the field.

SN is available for all sizes.

With the built-in slam shut, the Cg valve coefficients is 5% lower than the corresponding version without.

The main characteristics of this device are:

- | | | | |
|---|-------------------------------|---|------------------------|
|  OPSO | Over Pressure Shut-Off |  | Compact dimensions |
|  UPSO | Under Pressure Shut-Off |  | Easy maintenance |
|  | Internal by-pass |  | Remote tripping option |
|  | Push button for tripping test |  | Limit switch option |

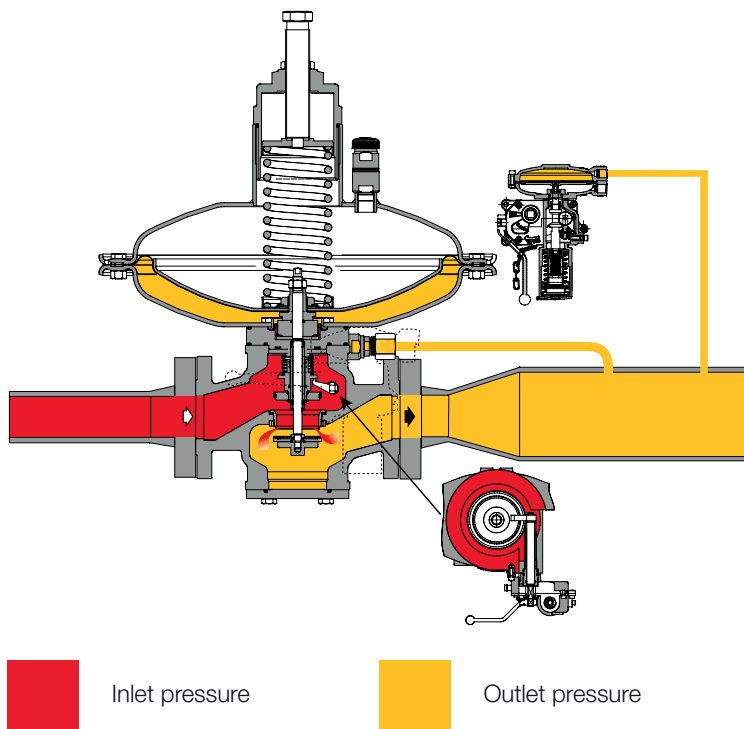

Figure 8 Norval with SN



Pressure switch types and ranges					
SSV Type	Model	Operation	Range Wh		Spring Table web link
			kPa	mbar	
SN	91	OPSO	2.5 - 110	25 - 1100	TT 1381
		UPSO	1 - 90	10 - 900	
SN (Upside-down)	91	OPSO	2.5 - 110	25 - 1100	TT 1381
		UPSO	1 - 90	10 - 900	
SSV Type	Model	Operation	Range Wh		Spring Table web link
			MPa	barg	
SN	92	OPSO	0.07 - 0.5	0.7 - 5	TT 1381
		UPSO	0.025 - 0.301	0.25 - 3.01	

Table 8 Settings table

Norval HC version

The Norval HC (High Capacity) version is designed to handle a higher capacity compared to the standard one.

This version has the same functional elements as the standard one, except:

- Regulator seat
- Flow deflector

This version is available for size 2" (DN50) d.495 mm with ductile iron body and maximum inlet pressure of 1.7 MPa | 17 bar only.

All Norval's accessories are available, except the silencer.

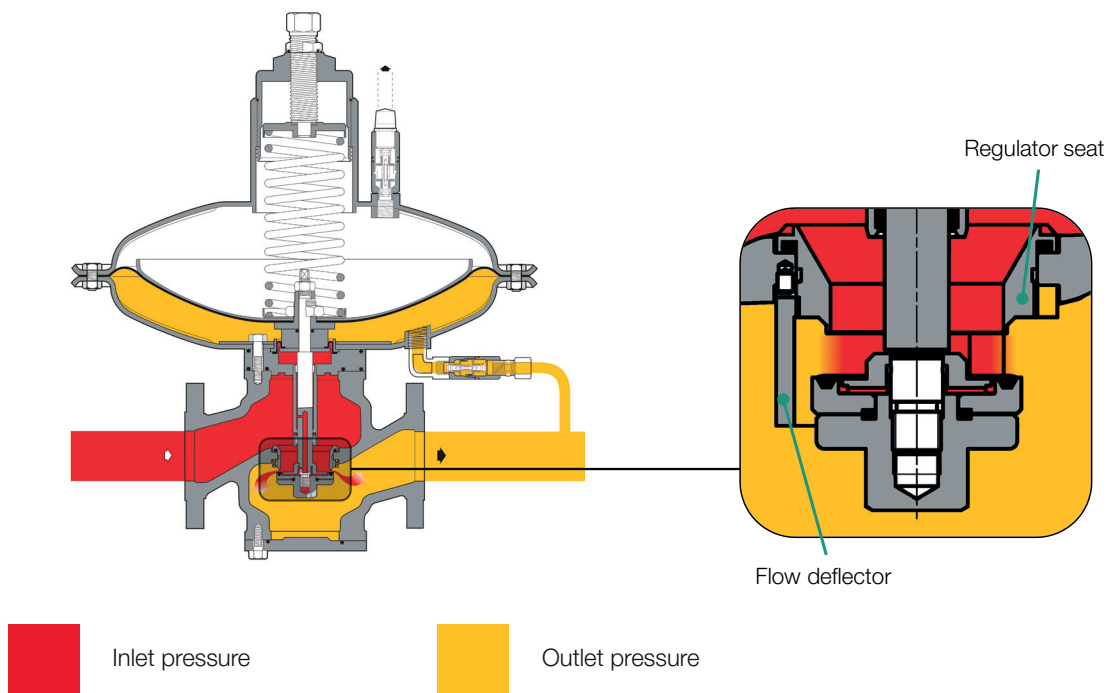

Figure 9 Norval HC with details

Gas flow

Standard version with frontal SSV

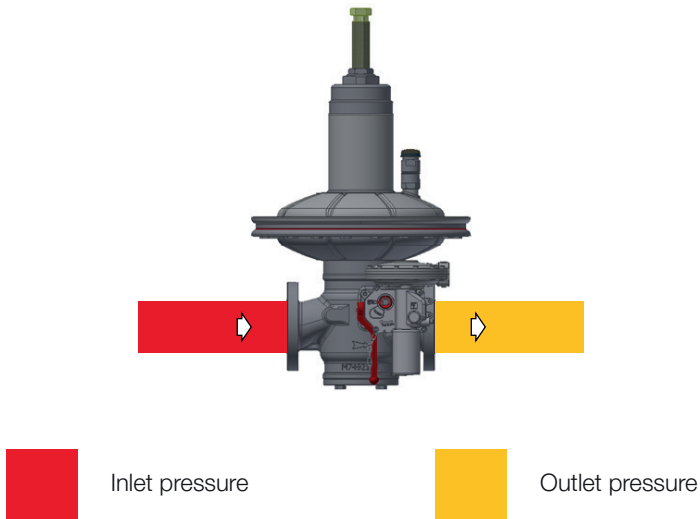

Figure 10 Norval standard version gas flow

Upside down version

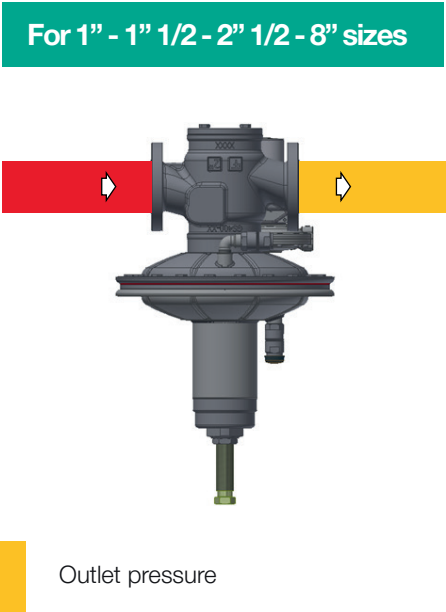
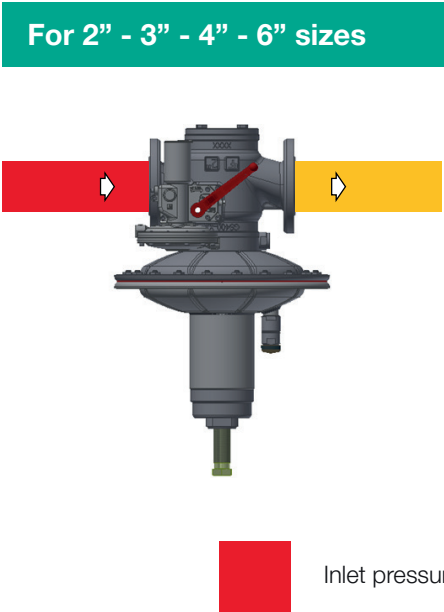
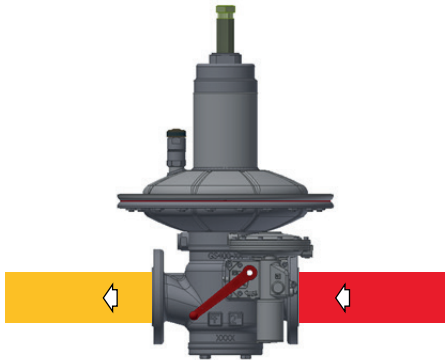



Figure 11 Norval standard version gas flow upside down



Right to left gas flow version

For 2" - 3" - 4" - 6" sizes



 Inlet pressure

For 1" - 1 1/2" - 2 1/2" - 8" sizes

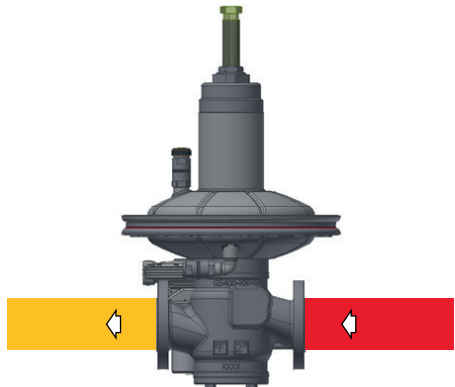

 Outlet pressure

Figure 12 Norval version right to left gas flow

Right to left gas flow version upside down

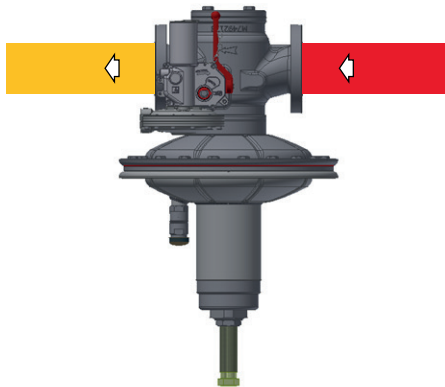

 Inlet pressure

 Outlet pressure

Figure 13 Upside down Norval version right to left gas flow

Weights and Dimensions

Norval with or without silencer

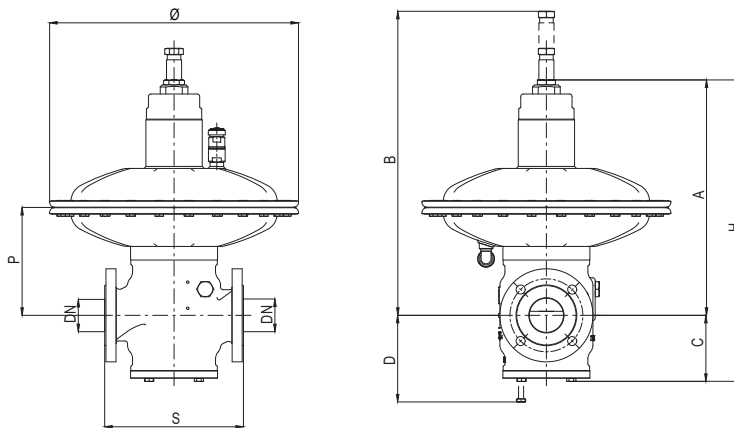

Figure 14 Norval dimensions

Weights and Dimensions (for other connections please contact your closest Pietro Fiorentini representative)								
	[mm] inches	[mm] inches	[mm] inches	[mm] inches	[mm] inches	[mm] inches	[mm] inches	[mm] inches
Size (DN)	25 1"	40 1 1/2"	50 2"	65 2 1/2"	80 3"	100 4"	150 6"	200 8"
S - Ansi 150/PN 16	183 7.2"	223 8.8"	254 10"	277 10.9"	298 11.7"	352 13.9"	451 17.8"	543 21.4"
A with Ø 375TR	425 16.7"	445 17.5"	445 17.5"	465 18.3"	465 18.3"	565 22.2"	-	-
A with Ø 375	415 16.3"	435 17.1"	435 17.1"	455 17.9"	455 17.9"	555 21.8"	-	-
A with Ø 495	460 18.1"	475 18.7"	475 18.7"	500 19.7"	500 19.7"	600 23.6"	670 26.4"	770 26.4"
A with Ø 630	-	-	-	540 21.3"	540 21.3"	640 25.2"	675 26.6"	775 30.6"
A with Ø 658	-	-	-	-	-	-	720 28.3"	820 32.3"
A with Ø 817	-	-	-	-	-	-	760 29.9"	860 33.9"
B with Ø 375TR	595 23.4"	615 24.2"	615 24.2"	635 25"	635 25"	735 28.9"	-	-
B with Ø 375	585 23.0"	605 23.8"	605 23.8"	625 24.6"	625 24.6"	725 28.5"	-	-
B with Ø 495	630 24.8"	645 25.4"	645 25.4"	670 26.4"	670 26.4"	770 30.3"	840 33.1"	940 37"
B with Ø 630	-	-	-	710 27.9"	710 27.9"	810 31.9"	845 33.3"	845 33.3"
B with Ø 658	-	-	-	-	-	-	890 35"	990 39"
B with Ø 817	-	-	-	-	-	-	930 36.6"	1030 40.6"
C	100 3.94"	120 4.72"	120 4.72"	140 5.5"	140 5.5"	180 7.09"	220 8.66"	260 10.2"
D	140 5.5"	160 6.3"	160 6.3"	180 7.09"	180 7.09"	220 8.66"	260 10.2"	300 11.8"
H with Ø 375TR	525 20.7"	165 6.5"	575 22.6"	605 23.8"	505 19.9"	745 29.3"	-	-
H with Ø 375	515 20.3"	555 21.8"	555 21.8"	595 23.4"	595 23.4"	735 28.9"	-	-
H with Ø 495	560 22"	595 23.4"	595 23.4"	640 25.2"	640 25.2"	780 30.7"	890 35"	1200 47"
H with Ø 630	-	-	-	680 26.8"	680 26.8"	820 32.3"	895 35.2"	1105 43.5"
H with Ø 658	-	-	-	-	-	-	940 37"	1250 49.2"
H with Ø 817	-	-	-	-	-	-	980	1290
P with Ø 375TR	155 6.1"	170 6.7"	170 6.7"	195 7.7"	195 7.7"	280 11"	-	-
P with Ø 375	150 5.9"	165 6.5"	165 6.5"	190 7.5"	190 7.5"	275 10.8"	-	-
P with Ø 495	175 6.9"	190 7.5"	190 7.5"	210 8.3"	210 8.3"	300 11.8"	375 14.8"	475 18.7"
P with Ø 630	-	-	-	220 8.7"	220 8.7"	310 12.2"	380 15"	480 18.9"
P with Ø 658	-	-	-	-	-	-	380 15"	480 18.9"
P with Ø 817	-	-	-	-	-	-	400 15.7"	500 19.7"
Tube Connections	Øe 10 x Øi 8 (on request imperial sizing)							

Weight	Kg lbs	Kg lbs	Kg lbs	Kg lbs	Kg lbs	Kg lbs	Kg lbs	Kg lbs
ANSI150/PN 16	44 97	48 106	50 110	75 165	92 203	121 267	206 454	291 641

Table 9 Weights and dimensions

Norval + SN with or without silencer

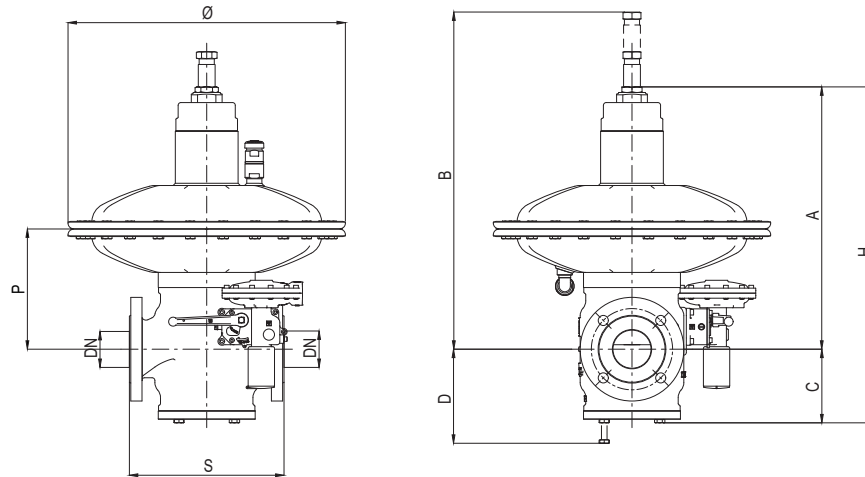

Figure 15 Norval + SN dimensions

Weights and Dimensions (for other connections please contact your closest Pietro Fiorentini representative)								
	[mm] inches	[mm] inches	[mm] inches	[mm] inches	[mm] inches	[mm] inches	[mm] inches	[mm] inches
Size (DN)	25 1"	40 1 1/2"	50 2"	65 2 1/2"	80 3"	100 4"	150 6"	200 8"
S - Ansi 150/PN 16	183 7.2"	223 8.8"	254 10"	277 10.9"	298 11.7"	352 13.9"	451 17.8"	543 21.4"
A with Ø 375TR	425 16.7"	445 17.5"	445 17.5"	465 18.3"	465 18.3"	565 22.2"	-	-
A with Ø 375	415 16.3"	435 17.1"	435 17.1"	455 17.9"	455 17.9"	555 21.8"	-	-
A with Ø 495	460 18.1"	475 18.7"	475 18.7"	500 19.7"	500 19.7"	600 23.6"	670 26.4"	770 26.4"
A with Ø 630	-	-	-	540 21.3"	540 21.3"	640 25.2"	675 26.6"	775 30.6"
A with Ø 658	-	-	-	-	-	-	720 28.3"	820 32.3"
A with Ø 817	-	-	-	-	-	-	760 29.9"	860 33.9"
B with Ø 375TR	595 23.4"	615 24.2"	615 24.2"	635 25"	635 25"	735 28.9"	-	-
B with Ø 375	585 23.0"	605 23.8"	605 23.8"	625 24.6"	625 24.6"	725 28.5"	-	-
B with Ø 495	630 24.8"	645 25.4"	645 25.4"	670 26.4"	670 26.4"	770 30.3"	840 33.1"	940 37"
B with Ø 630	-	-	-	710 27.9"	710 27.9"	810 31.9"	845 33.3"	845 33.3"
B with Ø 658	-	-	-	-	-	-	890 35"	990 39"
B with Ø 817	-	-	-	-	-	-	930 36.6"	1030 40.6"
C	100 3.94"	120 4.72"	120 4.72"	140 5.5"	140 5.5"	180 7.09"	220 8.66"	260 10.2"
D	140 5.5"	160 6.3"	160 6.3"	180 7.09"	180 7.09"	220 8.66"	260 10.2"	300 11.8"
H with Ø 375TR	525 20.7"	165 6.5"	575 22.6"	605 23.8"	505 19.9"	745 29.3"	-	-
H with Ø 375	515 20.3"	555 21.8"	555 21.8"	595 23.4"	595 23.4"	735 28.9"	-	-
H with Ø 495	560 22"	595 23.4"	595 23.4"	640 25.2"	640 25.2"	780 30.7"	890 35"	1200 47"
H with Ø 630	-	-	-	680 26.8"	680 26.8"	820 32.3"	895 35.2"	1105 43.5"
H with Ø 658	-	-	-	-	-	-	940 37"	1250 49.2"
H with Ø 817	-	-	-	-	-	-	980	1290
P with Ø 375TR	155 6.1"	170 6.7"	170 6.7"	195 7.7"	195 7.7"	280 11"	-	-
P with Ø 375	150 5.9"	165 6.5"	165 6.5"	190 7.5"	190 7.5"	275 10.8"	-	-
P with Ø 495	175 6.9"	190 7.5"	190 7.5"	210 8.3"	210 8.3"	300 11.8"	375 14.8"	475 18.7"
P with Ø 630	-	-	-	220 8.7"	220 8.7"	310 12.2"	380 15"	480 18.9"
P with Ø 658	-	-	-	-	-	-	380 15"	480 18.9"
P with Ø 817	-	-	-	-	-	-	400 15.7"	500 19.7"
Tube Connections	Øe 10 x Øi 8 (on request imperial sizing)							

Weight	Kg lbs	Kg lbs	Kg lbs	Kg lbs	Kg lbs	Kg lbs	Kg lbs	Kg lbs
ANSI150/PN 16	48 106	53 117	55 121	82 181	97 214	126 278	211 465	296 653

Table 10 Weights and dimensions

Norval + ER attachment

with or without silencer

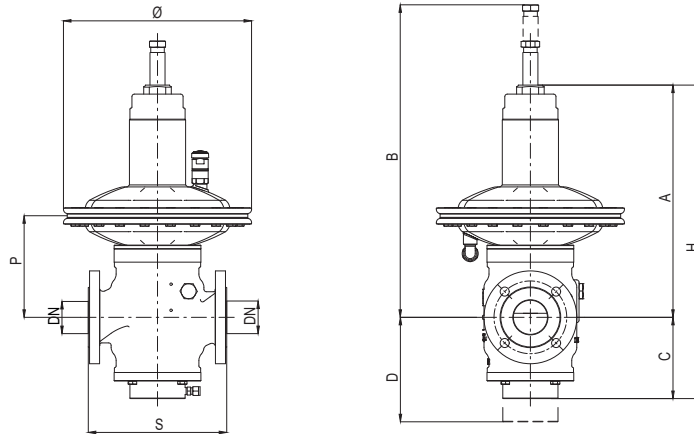

Figure 16 Norval + ER attachment dimensions

Weights and Dimensions (for other connections please contact your closest Pietro Fiorentini representative)								
	[mm] inches	[mm] inches	[mm] inches	[mm] inches	[mm] inches	[mm] inches	[mm] inches	[mm] inches
Size (DN)	25 1"	40 1 1/2"	50 2"	65 2 1/2"	80 3"	100 4"	150 6"	200 8"
S - Ansi 150/PN 16	183 7.2"	223 8.8"	254 10"	277 10.9"	298 11.7"	352 13.9"	451 17.8"	543 21.4"
A with Ø 375TR	425 16.7"	445 17.5"	445 17.5"	465 18.3"	465 18.3"	565 22.2"	-	-
A with Ø 375	415 16.3"	435 17.1"	435 17.1"	455 17.9"	455 17.9"	555 21.8"	-	-
A with Ø 495	460 18.1"	475 18.7"	475 18.7"	500 19.7"	500 19.7"	600 23.6"	670 26.4"	770 26.4"
A with Ø 630	-	-	-	540 21.3"	540 21.3"	640 25.2"	675 26.6"	775 30.6"
A with Ø 658	-	-	-	-	-	-	720 28.3"	820 32.3"
A with Ø 817	-	-	-	-	-	-	760 29.9"	860 33.9"
B with Ø 375TR	595 23.4"	615 24.2"	615 24.2"	635 25"	635 25"	735 28.9"	-	-
B with Ø 375	585 23.0"	605 23.8"	605 23.8"	625 24.6"	625 24.6"	725 28.5"	-	-
B with Ø 495	630 24.8"	645 25.4"	645 25.4"	670 26.4"	670 26.4"	770 30.3"	840 33.1"	940 37"
B with Ø 630	-	-	-	710 27.9"	710 27.9"	810 31.9"	845 33.3"	845 33.3"
B with Ø 658	-	-	-	-	-	-	890 35"	990 39"
B with Ø 817	-	-	-	-	-	-	930 36.6"	1030 40.6"
C	200 7.9"	220 8.66"	220 8.66"	240 9.45"	240 9.45"	280 11"	320 12.6"	360 14.2"
D	250 9.8"	270 10.6"	270 10.6"	290 11.4"	290 11.4"	330 13"	370 14.6"	410 16.1"
H with Ø 375TR	625 24.6"	665 26.2"	665 26.2"	705 27.8"	705 27.8"	845 33.3"	-	-
H with Ø 375	615 24.2"	655 25.8"	655 25.8"	695 27.4"	695 27.4"	835 33"	-	-
H with Ø 495	660 26"	695 27"	695 27"	740 29"	740 29"	880 34.6"	990 39"	1130 44.5"
H with Ø 630	-	-	-	780 30.7"	780 30.7"	920 36.2"	995 39.2"	1135 44.7"
H with Ø 658	-	-	-	-	-	-	1040 41"	1180 46.5"
H with Ø 817	-	-	-	-	-	-	1080 42.5"	1220 48"
P with Ø 375TR	155 6.1"	170 6.7"	170 6.7"	195 7.7"	195 7.7"	280 11"	-	-
P with Ø 375	150 5.9"	165 6.5"	165 6.5"	190 7.5"	190 7.5"	275 10.8"	-	-
P with Ø 495	175 6.9"	190 7.5"	190 7.5"	210 8.3"	210 8.3"	300 11.8"	375 14.8"	475 18.7"
P with Ø 630	-	-	-	220 8.7"	220 8.7"	310 12.2"	380 15"	480 18.9"
P with Ø 658	-	-	-	-	-	-	380 15"	480 18.9"
P with Ø 817	-	-	-	-	-	-	400 15.7"	500 19.7"
Tube Connections	Øe 10 x Ø 8 (on request imperial sizing)							

Weight	Kg lbs	Kg lbs	Kg lbs	Kg lbs	Kg lbs	Kg lbs	Kg lbs	Kg lbs
ANSI150/PN 16	48 106	55 121	58 128	85 187	100 220	129 284	216 476	302 666

Table 11 Weights and dimensions



Norval + SN + ER attachment

with or without silencer

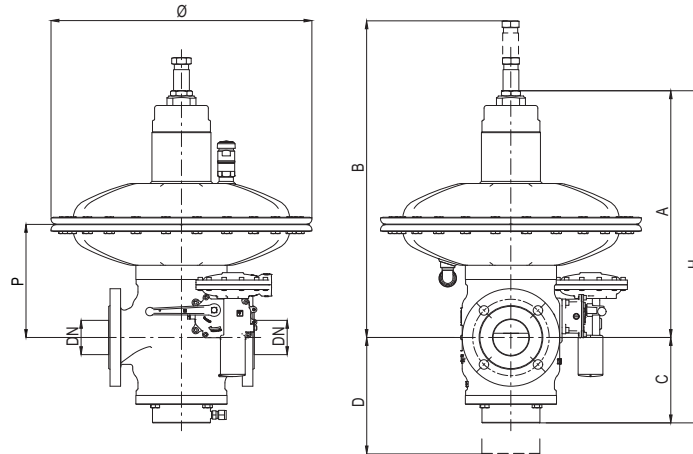

Figure 17 Norval + SN + ER attachment dimensions

Weights and Dimensions (for other connections please contact your closest Pietro Fiorentini representative)								
	[mm] inches	[mm] inches	[mm] inches	[mm] inches	[mm] inches	[mm] inches	[mm] inches	[mm] inches
Size (DN)	25 1"	40 1 1/2"	50 2"	65 2 1/2"	80 3"	100 4"	150 6"	200 8"
S - Ansi 150/PN 16	183 7.2"	223 8.8"	254 10"	277 10.9"	298 11.7"	352 13.9"	451 17.8"	543 21.4"
A with Ø 375TR	425 16.7"	445 17.5"	445 17.5"	465 18.3"	465 18.3"	565 22.2"	-	-
A with Ø 375	415 16.3"	435 17.1"	435 17.1"	455 17.9"	455 17.9"	555 21.8"	-	-
A with Ø 495	460 18.1"	475 18.7"	475 18.7"	500 19.7"	500 19.7"	600 23.6"	670 26.4"	770 26.4"
A with Ø 630	-	-	-	540 21.3"	540 21.3"	640 25.2"	675 26.6"	775 30.6"
A with Ø 658	-	-	-	-	-	-	720 28.3"	820 32.3"
A with Ø 817	-	-	-	-	-	-	760 29.9"	860 33.9"
B with Ø 375TR	595 23.4"	615 24.2"	615 24.2"	635 25"	635 25"	735 28.9"	-	-
B with Ø 375	585 23.0"	605 23.8"	605 23.8"	625 24.6"	625 24.6"	725 28.5"	-	-
B with Ø 495	630 24.8"	645 25.4"	645 25.4"	670 26.4"	670 26.4"	770 30.3"	840 33.1"	940 37"
B with Ø 630	-	-	-	710 27.9"	710 27.9"	810 31.9"	845 33.3"	845 33.3"
B with Ø 658	-	-	-	-	-	-	890 35"	990 39"
B with Ø 817	-	-	-	-	-	-	930 36.6"	1030 40.6"
C	200 7.9"	220 8.66"	220 8.66"	240 9.45"	240 9.45"	280 11"	320 12.6"	360 14.2"
D	250 9.8"	270 10.6"	270 10.6"	290 11.4"	290 11.4"	330 13"	370 14.6"	410 16.1"
H with Ø 375TR	625 24.6"	665 26.2"	665 26.2"	705 27.8"	705 27.8"	845 33.3"	-	-
H with Ø 375	615 24.2"	655 25.8"	655 25.8"	695 27.4"	695 27.4"	835 33"	-	-
H with Ø 495	660 26"	695 27"	695 27"	740 29"	740 29"	880 34.6"	990 39"	1130 44.5"
H with Ø 630	-	-	-	780 30.7"	780 30.7"	920 36.2"	995 39.2"	1135 44.7"
H with Ø 658	-	-	-	-	-	-	1040 41"	1180 46.5"
H with Ø 817	-	-	-	-	-	-	1080 42.5"	1220 48"
P with Ø 375TR	155 6.1"	170 6.7"	170 6.7"	195 7.7"	195 7.7"	280 11"	-	-
P with Ø 375	150 5.9"	165 6.5"	165 6.5"	190 7.5"	190 7.5"	275 10.8"	-	-
P with Ø 495	175 6.9"	190 7.5"	190 7.5"	210 8.3"	210 8.3"	300 11.8"	375 14.8"	475 18.7"
P with Ø 630	-	-	-	220 8.7"	220 8.7"	310 12.2"	380 15"	480 18.9"
P with Ø 658	-	-	-	-	-	-	380 15"	480 18.9"
P with Ø 817	-	-	-	-	-	-	400 15.7"	500 19.7"
Tube Connections	Øe 10 x Øi 8 (on request imperial sizing)							

Weight	Kg lbs	Kg lbs	Kg lbs	Kg lbs	Kg lbs	Kg lbs	Kg lbs	Kg lbs
ANSI150/PN 16	53 117	60 132	63 139	90 198	105 33	134 295	221 487	307 677

Table 12 Weights and dimensions

Sizing and Cg

In general, the choice of a regulator is made based on the calculation of the flow rate determined by the use of formulae using the flow rate coefficients (Cg) and the form factor (K1) as indicated by the EN 334 standard.

Flow rate coefficient								
Nominal size	25	40	50	65	80	100	150	200
Inches	1"	1" 1/2	2"	2" 1/2	3"	4"	6"	8"
Cg	331	848	1360	2240	3395	5100	10600	16600
K1	106.78	106.78	106.78	106.78	106.78	106.78	106.78	106.78

Table 13 Flow rate coefficient

For sizing [PRESS HERE](#) or use the QR code:



Note: In case you do not have the proper credentials to access, feel free to contact your closest Pietro Fiorentini representative.

In general the online sizing considers multiple variables as the regulator is installed in a system, enabling a better and multiperspective approach to the sizing.

For different gases, and for natural gas with a different relative density other than 0.61 (compared to air), the correction coefficients from the following formula shall be applied.

$$F_c = \sqrt{\frac{175.8}{S \times (273.16 + T)}}$$

S = relative density (refer to Table 14)
T = gas temperature (°C)

$$F_c = \sqrt{\frac{316.44}{S \times (459.67 + T)}}$$

S = relative density (refer to Table 14)
T = gas temperature (°F)



Correction Factor Fc		
Gas Type	Relative Density S	Correction Factor Fc
Air	1.00	0.78
Propane	1.53	0.63
Butane	2.00	0.55
Nitrogen	0.97	0.79
Oxygen	1.14	0.73
Carbon Dioxide	1.52	0.63

Note: the table shows the Fc correction factors valid for Gas, calculated at a temperature of 15°C and at the declared relative density.

Table 14 Correction Factor Fc

Flow rate conversion
$\text{Stm}^3/\text{h} \times 0.94795 = \text{Nm}^3/\text{h}$

Nm³/h reference conditions T= 0 °C; P= 1 barg
 Stm³/h reference conditions T= 15 °C; P= 1 barg

Table 15 Flow rate conversion

CAUTION:

In order to get optimal performance, to avoid premature erosion phenomena and to limit noise emissions, it is recommended to check the gas speed and its compliance with local practice and regulations. The gas speed at the outlet flange may be calculated by means of the following formula:

$$V = 345.92 \times \frac{Q}{\text{DN}^2} \times \frac{1 - 0.002 \times \text{Pd}}{1 + \text{Pd}}$$

$$V = 0.0498 \times \frac{Q}{\text{DN}^2} \times \frac{14.504 - 0.002 \times \text{Pd}}{14.504 + \text{Pd}}$$

V = gas speed in m/s
 Q = gas flow rate in Stm³/h
 DN = nominal size of regular in mm
 Pd = outlet pressure in barg

V = gas speed in ft/s
 Q = gas flow rate in Scfh
 DN = nominal size of regular in inches
 Pd = outlet pressure in psi

Norval - DN 1" d.495 mm

from 2 kPa | 20 mbarg up to 8 kPa | 80 mbarg

flow capacity table

Norval flow rate (Accuracy 10% ; AC10 according to EN334)											
Inlet pressure		Outlet pressure									
		2 kPa 20 mbarg		4 kPa 40 mbarg		5 kPa 50 mbarg		6 kPa 60 mbarg		8 kPa 80 mbarg	
MPa	barg	Stm ³ /h	Scfh	Stm ³ /h	Scfh	Stm ³ /h	Scfh	Stm ³ /h	Scfh	Stm ³ /h	Scfh
0.05	0.5	215	7600	210	7500	210	7500	210	7500	200	7100
0.1	1	250	8900	260	9200	310	11000	310	11000	310	11000
0.2	2	300	10600	290	10300	450	15900	470	16600	470	16600
0.4	4	310	11000	300	10600	480	17000	500	17700	600	21200
0.8	8	350	12400	360	12800	495	17500	545	19300	615	21800
1	10	370	13100	390	13800	535	18900	595	21100	675	23900
1.6	16	545	19300	535	18900	575	20400	640	22700	730	25800

CG = 331 K1= 106.78

Table 16 Norval flow rate with outlet pressure from 2 kPa | 20 mbarg up to 8 kPa | 80 mbarg

Norval flow rate (Accuracy 20% ; AC20 according to EN334)											
Inlet pressure		Outlet pressure									
		2 kPa 20 mbarg		4 kPa 40 mbarg		5 kPa 50 mbarg		6 kPa 60 mbarg		8 kPa 80 mbarg	
MPa	barg	Stm ³ /h	Scfh	Stm ³ /h	Scfh	Stm ³ /h	Scfh	Stm ³ /h	Scfh	Stm ³ /h	Scfh
0.05	0.5	280	9900	280	9900	230	8200	250	8900	270	9600
0.1	1	340	12100	340	12100	350	12400	370	13100	400	14200
0.2	2	470	16600	470	16600	500	17700	500	17700	550	19500
0.4	4	480	17000	480	17000	550	19500	550	19500	700	24800
0.8	8	515	18200	595	21100	675	23900	645	22800	875	31000
1	10	535	18900	645	22800	715	25300	745	26400	890	31500
1.6	16	620	21900	740	26200	790	27900	790	27900	985	34800

CG = 331 K1= 106.78

Table 17 Norval flow rate with outlet pressure from 2 kPa | 20 mbarg up to 8 kPa | 80 mbarg



Norval - DN 1" d.375 mm

from 8 kPa | 80 mbarg up to 110 kPa | 1100 mbarg
flow capacity table

Norval flow rate (Accuracy 10% ; AC10 according to EN334)											
Inlet pressure		Outlet pressure									
		8 kPa 80 mbarg		15 kPa 150 mbarg		53 kPa 530 mbarg		76 kPa 760 mbarg		110 kPa 1100 mbarg	
MPa	barg	Stm³/h	Scfh	Stm³/h	Scfh	Stm³/h	Scfh	Stm³/h	Scfh	Stm³/h	Scfh
0.05	0.5	200	7100	180	6400	-	-	-	-	-	-
0.1	1	310	11000	310	11000	260	9200	195	6900	-	-
0.2	2	470	16600	450	15900	480	17000	450	15900	400	14200
0.4	4	600	21200	500	17700	820	29000	800	28300	800	28300
0.8	8	615	21800	575	20400	1075	38000	1190	42100	1390	49100
1	10	675	23900	615	21800	1070	37800	1240	43800	1485	52500
1.6	16	730	25800	690	24400	1065	37700	1235	43700	1480	52300

CG = 331 K1= 106.78

Table 18 Norval flow rate with outlet pressure from 8 kPa | 80 mbarg up to 110 kPa | 1100 mbarg

Norval flow rate (Accuracy 20% ; AC20 according to EN334)											
Inlet pressure		Outlet pressure									
		8 kPa 80 mbarg		15 kPa 150 mbarg		53 kPa 530 mbarg		76 kPa 760 mbarg		110 kPa 1100 mbarg	
MPa	barg	Stm³/h	Scfh	Stm³/h	Scfh	Stm³/h	Scfh	Stm³/h	Scfh	Stm³/h	Scfh
0.05	0.5	270	9600	180	6400	-	-	-	-	-	-
0.1	1	400	14200	340	12100	350	12400	265	9400	-	-
0.2	2	550	19500	600	21200	600	21200	540	19100	550	19500
0.4	4	700	24800	700	24800	945	33400	995	35200	1000	35400
0.8	8	875	31000	845	29900	1290	45600	1540	54400	1590	56200
1	10	890	31500	890	31500	1340	47400	1535	54300	1785	63100
1.6	16	985	34800	1005	35500	1330	47000	1530	54100	1825	64500

CG = 331 K1= 106.78

Table 19 Norval flow rate with outlet pressure from 8 kPa | 80 mbarg up to 110 kPa | 1100 mbarg

Norval - DN 1" d.375/TR mm

from 90 kPa | 900 mbarg up to 440 kPa | 4400 mbarg
flow capacity table

Norval flow rate (Accuracy 10% ; AC10 according to EN334)											
Inlet pressure		Outlet pressure									
		90 kPa 900 mbarg		150 kPa 1500 mbarg		260 kPa 2600 mbarg		350 kPa 3500 mbarg		440 kPa 4400 mbarg	
MPa	barg	Stm ³ /h	Scfh	Stm ³ /h	Scfh	Stm ³ /h	Scfh	Stm ³ /h	Scfh	Stm ³ /h	Scfh
0.05	0.5	-	-	-	-	-	-	-	-	-	-
0.1	1	-	-	-	-	-	-	-	-	-	-
0.2	2	450	15900	340	12100	-	-	-	-	-	-
0.4	4	800	28300	800	28300	700	24800	450	15900	-	-
0.8	8	1095	38700	1440	50900	1445	51100	1445	51100	1345	47500
1	10	1190	42100	1735	61300	1785	63100	1790	63300	1790	63300
1.6	16	1320	46700	1725	61000	2270	80200	2670	94300	2770	97900

CG = 331 K1= 106.78

Table 20 Norval flow rate with outlet pressure from 90 kPa | 900 mbarg up to 440 kPa | 4400 mbarg

Norval flow rate (Accuracy 20% ; AC20 according to EN334)											
Inlet pressure		Outlet pressure									
		90 kPa 900 mbarg		150 kPa 1500 mbarg		260 kPa 2600 mbarg		350 kPa 3500 mbarg		440 kPa 4400 mbarg	
MPa	barg	Stm ³ /h	Scfh	Stm ³ /h	Scfh	Stm ³ /h	Scfh	Stm ³ /h	Scfh	Stm ³ /h	Scfh
0.05	0.5	-	-	-	-	-	-	-	-	-	-
0.1	1	-	-	-	-	-	-	-	-	-	-
0.2	2	600	21200	540	19100	-	-	-	-	-	-
0.4	4	1000	35400	1000	35400	950	33600	900	31800	-	-
0.8	8	1490	52700	1590	56200	1790	63300	1990	70300	1995	70500
1	10	1585	56000	1785	63100	2085	73700	2385	84300	2485	87800
1.6	16	1655	58500	2170	76700	2665	94200	3160	111600	3265	115400

CG = 331 K1= 106.78

Table 21 Norval flow rate with outlet pressure from 90 kPa | 900 mbarg up to 440 kPa | 4400 mbarg



Norval - DN 1" 1/2 d.495 mm

from 2 kPa | 20 mbarg up to 8 kPa | 80 mbarg

flow capacity table

Norval flow rate (Accuracy 10% ; AC10 according to EN334)											
Inlet pressure		Outlet pressure									
		2 kPa 20 mbarg		4 kPa 40 mbarg		5 kPa 50 mbarg		6 kPa 60 mbarg		8 kPa 80 mbarg	
MPa	barg	Stm ³ /h	Scfh	Stm ³ /h	Scfh	Stm ³ /h	Scfh	Stm ³ /h	Scfh	Stm ³ /h	Scfh
0.05	0.5	550	19500	520	18400	540	19100	520	18400	520	18400
0.1	1	650	23000	650	23000	800	28300	800	28300	800	28300
0.2	2	800	28300	750	26500	1150	40700	1200	42400	1200	42400
0.4	4	845	29900	780	27600	1195	42300	1295	45800	1495	52800
0.8	8	895	31700	895	31700	1290	45600	1490	52700	1685	59600
1	10	990	35000	990	35000	1335	47200	1585	56000	1785	63100
1.6	16	1430	50600	1380	48800	1575	55700	1775	62700	1920	67900

CG = 848 K1= 106.78

Table 22 Norval flow rate with outlet pressure from 2 kPa | 20 mbarg up to 8 kPa | 80 mbarg

Norval flow rate (Accuracy 20% ; AC20 according to EN334)											
Inlet pressure		Outlet pressure									
		2 kPa 20 mbarg		4 kPa 40 mbarg		5 kPa 50 mbarg		6 kPa 60 mbarg		8 kPa 80 mbarg	
MPa	barg	Stm ³ /h	Scfh	Stm ³ /h	Scfh	Stm ³ /h	Scfh	Stm ³ /h	Scfh	Stm ³ /h	Scfh
0.05	0.5	680	24100	680	24100	650	23000	650	23000	700	24800
0.1	1	850	30100	850	30100	850	30100	850	30100	900	31800
0.2	2	1200	42400	1200	42400	1200	42400	1200	42400	1395	49300
0.4	4	1245	44000	1245	44000	1395	49300	1395	49300	1595	56400
0.8	8	1290	45600	1390	49100	1735	61300	1735	61300	1885	66600
1	10	1290	45600	1435	50700	1830	64700	1830	64700	1980	70000
1.6	16	1575	55700	1725	61000	1970	69600	1970	69600	2070	73200

CG = 848 K1= 106.78

Table 23 Norval flow rate with outlet pressure from 2 kPa | 20 mbarg up to 8 kPa | 80 mbarg

Norval - DN 1" 1/2 d.375 mm

from 8 kPa | 80 mbarg up to 110 kPa | 1100 mbarg

flow capacity table

Norval flow rate (Accuracy 10% ; AC10 according to EN334)											
Inlet pressure		Outlet pressure									
		8 kPa 80 mbarg		15 kPa 150 mbarg		53 kPa 530 mbarg		76 kPa 760 mbarg		110 kPa 1100 mbarg	
MPa	barg	Stm ³ /h	Scfh	Stm ³ /h	Scfh	Stm ³ /h	Scfh	Stm ³ /h	Scfh	Stm ³ /h	Scfh
0.05	0.5	520	18400	500	17700	-	-	-	-	-	-
0.1	1	800	28300	800	28300	650	23000	485	17200	-	-
0.2	2	1200	42400	1200	42400	1200	42400	1100	38900	1050	37100
0.4	4	1495	52800	1495	52800	1990	70300	1995	70500	1995	70500
0.8	8	1685	59600	1785	63100	2680	94700	2975	105100	3475	122800
1	10	1785	63100	1880	66400	2775	98000	3170	112000	3665	129500
1.6	16	1920	67900	2070	73200	2760	97500	3155	111500	3745	132300

CG = 848 K1= 106.78

Table 24 Norval flow rate with outlet pressure from 8 kPa | 80 mbarg up to 110 kPa | 1100 mbarg

Norval flow rate (Accuracy 20% ; AC20 according to EN334)											
Inlet pressure		Outlet pressure									
		8 kPa 80 mbarg		15 kPa 150 mbarg		53 kPa 530 mbarg		76 kPa 760 mbarg		110 kPa 1100 mbarg	
MPa	barg	Stm ³ /h	Scfh	Stm ³ /h	Scfh	Stm ³ /h	Scfh	Stm ³ /h	Scfh	Stm ³ /h	Scfh
0.05	0.5	700	24800	550	19500	-	-	-	-	-	-
0.1	1	900	31800	800	28300	850	30100	645	22800	-	-
0.2	2	1395	49300	1495	52800	1500	53000	1500	53000	1300	46000
0.4	4	1595	56400	1695	59900	2690	95000	2590	91500	2490	88000
0.8	8	1885	66600	1985	70100	3420	120800	3970	140200	4265	150700
1	10	1980	70000	2080	73500	3415	120600	3960	139900	4360	154000
1.6	16	2070	73200	2560	90500	3400	120100	3945	139400	4685	165500

CG = 848 K1= 106.78

Table 25 Norval flow rate with outlet pressure from 8 kPa | 80 mbarg up to 110 kPa | 1100 mbarg



Norval - DN 1" 1/2 d.375/TR mm

from 90 kPa | 900 mbarg up to 440 kPa | 4400 mbarg
flow capacity table

Norval flow rate (Accuracy 10% ; AC10 according to EN334)											
Inlet pressure		Outlet pressure									
		90 kPa 900 mbarg		150 kPa 1500 mbarg		260 kPa 2600 mbarg		350 kPa 3500 mbarg		440 kPa 4400 mbarg	
MPa	barg	Stm ³ /h	Scfh	Stm ³ /h	Scfh	Stm ³ /h	Scfh	Stm ³ /h	Scfh	Stm ³ /h	Scfh
0.05	0.5	-	-	-	-	-	-	-	-	-	-
0.1	1	-	-	-	-	-	-	-	-	-	-
0.2	2	1100	38900	850	30100	-	-	-	-	-	-
0.4	4	1995	70500	1995	70500	1700	60100	1150	40700	-	-
0.8	8	2780	98200	3575	126300	3580	126500	3580	126500	3385	119600
1	10	2970	104900	3765	133000	4365	154200	4470	157900	4475	158100
1.6	16	3350	118400	4440	156800	6415	226600	6720	237400	6725	237500

CG = 848 K1= 106.78

Table 26 Norval flow rate with outlet pressure from 90 kPa | 900 mbarg up to 440 kPa | 4400 mbarg

Norval flow rate (Accuracy 20% ; AC20 according to EN334)											
Inlet pressure		Outlet pressure									
		90 kPa 900 mbarg		150 kPa 1500 mbarg		260 kPa 2600 mbarg		350 kPa 3500 mbarg		440 kPa 4400 mbarg	
MPa	barg	Stm ³ /h	Scfh	Stm ³ /h	Scfh	Stm ³ /h	Scfh	Stm ³ /h	Scfh	Stm ³ /h	Scfh
0.05	0.5	-	-	-	-	-	-	-	-	-	-
0.1	1	-	-	-	-	-	-	-	-	-	-
0.2	2	1400	49500	1300	46000	-	-	-	-	-	-
0.4	4	2690	95000	2690	95000	2695	95200	2000	70700	-	-
0.8	8	4265	150700	4270	150800	4475	158100	5470	193200	5975	211100
1	10	4260	150500	4460	157600	4960	175200	6455	228000	6955	245700
1.6	16	4240	149800	5425	191600	6415	226600	7905	279200	8900	314400

CG = 848 K1= 106.78

Table 27 Norval flow rate with outlet pressure from 90 kPa | 900 mbarg up to 440 kPa | 4400 mbarg

Norval - DN 2" d.495 mm

from 2 kPa | 20 mbarg up to 8 kPa | 80 mbarg

flow capacity table

Norval flow rate (Accuracy 10% ; AC10 according to EN334)											
Inlet pressure		Outlet pressure									
		2 kPa 20 mbarg		4 kPa 40 mbarg		5 kPa 50 mbarg		6 kPa 60 mbarg		8 kPa 80 mbarg	
MPa	barg	Stm ³ /h	Scfh	Stm ³ /h	Scfh	Stm ³ /h	Scfh	Stm ³ /h	Scfh	Stm ³ /h	Scfh
0.05	0.5	900	31800	880	31100	880	31100	870	30800	850	30100
0.1	1	1000	35400	1050	37100	1300	46000	1300	46000	1300	46000
0.2	2	1200	42400	1230	43500	1875	66300	1995	70500	1995	70500
0.4	4	1195	42300	1195	42300	1960	69300	2190	77400	2490	88000
0.8	8	1470	52000	1470	52000	2035	71900	2380	84100	2530	89400
1	10	1585	56000	1585	56000	2180	77000	2475	87500	2770	97900
1.6	16	2235	79000	2235	79000	2710	95800	2760	97500	3005	106200

CG = 1360 K1= 106.78

Table 28 Norval flow rate with outlet pressure from 2 kPa | 20 mbarg up to 8 kPa | 80 mbarg

Norval flow rate (Accuracy 20% ; AC20 according to EN334)											
Inlet pressure		Outlet pressure									
		2 kPa 20 mbarg		4 kPa 40 mbarg		5 kPa 50 mbarg		6 kPa 60 mbarg		8 kPa 80 mbarg	
MPa	barg	Stm ³ /h	Scfh	Stm ³ /h	Scfh	Stm ³ /h	Scfh	Stm ³ /h	Scfh	Stm ³ /h	Scfh
0.05	0.5	1120	39600	1200	42400	1225	43300	1220	43100	1220	43100
0.1	1	1400	49500	1500	53000	1700	60100	1700	60100	1700	60100
0.2	2	1955	69100	2295	81100	2495	88200	2495	88200	2595	91700
0.4	4	1990	70300	2390	84500	2795	98800	2590	91500	3385	119600
0.8	8	2085	73700	2580	91200	2795	98800	3075	108600	3620	127900
1	10	2080	73500	2675	94500	2870	101400	3165	111800	3615	127700
1.6	16	2560	90500	2955	104400	3200	113100	3350	118400	3745	132300

CG = 1360 K1= 106.78

Table 29 Norval flow rate with outlet pressure from 2 kPa | 20 mbarg up to 8 kPa | 80 mbarg



Norval HC - DN 2" d.495 mm

from 2 kPa | 20 mbarg up to 8 kPa | 80 mbarg

flow capacity table

Norval HC flow rate (Accuracy 10% ; AC10 according to EN334)											
Inlet pressure		Outlet pressure									
		2 kPa 20 mbarg		4 kPa 40 mbarg		5 kPa 50 mbarg		6 kPa 60 mbarg		8 kPa 80 mbarg	
MPa	barg	Stm³/h	Scfh	Stm³/h	Scfh	Stm³/h	Scfh	Stm³/h	Scfh	Stm³/h	Scfh
0.05	0.5	805	28500	830	29400	830	29400	830	29400	830	29400
0.1	1	1205	42600	1300	46000	1300	46000	1300	46000	1300	46000
0.2	2	1905	67300	1995	70500	1995	70500	1995	70500	1995	70500
0.4	4	2725	96300	2885	101900	2885	101900	2885	101900	3085	109000
0.8	8	2740	96800	2875	101600	2875	101600	3470	122600	3470	122600
1	10	2765	97700	2970	104900	2970	104900	3565	125900	3565	125900
1.6	16	2795	98800	3055	107900	3055	107900	3545	125200	3745	132300

CG = 1360 K1= 106.78

Table 30 Norval HC flow rate with outlet pressure from 2 kPa | 20 mbarg up to 8 kPa | 80 mbarg

Norval HC flow rate (Accuracy 20% ; AC20 according to EN334)											
Inlet pressure		Outlet pressure									
		2 kPa 20 mbarg		4 kPa 40 mbarg		5 kPa 50 mbarg		6 kPa 60 mbarg		8 kPa 80 mbarg	
MPa	barg	Stm³/h	Scfh	Stm³/h	Scfh	Stm³/h	Scfh	Stm³/h	Scfh	Stm³/h	Scfh
0.05	0.5	850	30100	850	30100	850	30100	850	30100	850	30100
0.1	1	1300	46000	1300	46000	1300	46000	1300	46000	1300	46000
0.2	2	2095	74000	2095	74000	2095	74000	2095	74000	2095	74000
0.4	4	3020	106700	3285	116100	3285	116100	3485	123100	3485	123100
0.8	8	3190	112700	3470	122600	3470	122600	3670	129700	3765	133000
1	10	3295	116400	3565	125900	3565	125900	3660	129300	3760	132800
1.6	16	3270	115500	3645	128800	3645	128800	3645	128800	3745	132300

CG = 1360 K1= 106.78

Table 31 Norval HC flow rate with outlet pressure from 2 kPa | 20 mbarg up to 8 kPa | 80 mbarg

Norval - DN 2" d.375 mm

from 8 kPa | 80 mbarg up to 110 kPa | 1100 mbarg

flow capacity table

Norval flow rate (Accuracy 10% ; AC10 according to EN334)											
Inlet pressure		Outlet pressure									
		8 kPa 80 mbarg		15 kPa 150 mbarg		53 kPa 530 mbarg		76 kPa 760 mbarg		110 kPa 1100 mbarg	
MPa	barg	Stm ³ /h	Scfh	Stm ³ /h	Scfh	Stm ³ /h	Scfh	Stm ³ /h	Scfh	Stm ³ /h	Scfh
0.05	0.5	850	30100	800	28300	-	-	-	-	-	-
0.1	1	1300	46000	1250	44200	1050	37100	800	28300	-	-
0.2	2	1995	70500	1895	67000	1995	70500	1895	67000	1700	60100
0.4	4	2490	88000	2090	73900	3285	116100	3385	119600	3390	119800
0.8	8	2530	89400	2280	80600	4265	150700	4960	175200	5955	210300
1	10	2770	97900	2375	83900	4260	150500	4950	174900	5945	210000
1.6	16	3005	106200	2955	104400	4235	149600	4930	174200	5915	208900

CG = 1360 K1= 106.78

Table 32 Norval flow rate with outlet pressure from 8 kPa | 80 mbarg up to 110 kPa | 1100 mbarg

Norval flow rate (Accuracy 20% ; AC20 according to EN334)											
Inlet pressure		Outlet pressure									
		8 kPa 80 mbarg		15 kPa 150 mbarg		53 kPa 530 mbarg		76 kPa 760 mbarg		110 kPa 1100 mbarg	
MPa	barg	Stm ³ /h	Scfh	Stm ³ /h	Scfh	Stm ³ /h	Scfh	Stm ³ /h	Scfh	Stm ³ /h	Scfh
0.05	0.5	1220	43100	900	31800	-	-	-	-	-	-
0.1	1	1700	60100	1400	49500	1500	53000	1270	44900	-	-
0.2	2	2595	91700	2595	91700	2695	95200	2595	91700	2685	94900
0.4	4	3385	119600	2885	101900	4880	172400	4840	171000	4880	172400
0.8	8	3620	127900	3270	115500	5455	192700	6150	217200	7340	259300
1	10	3615	127700	3465	122400	5445	192300	6140	216900	7330	258900
1.6	16	3745	132300	4040	142700	5420	191500	6110	215800	7295	257700

CG = 1360 K1= 106.78

Table 33 Norval flow rate with outlet pressure from 8 kPa | 80 mbarg up to 110 kPa | 1100 mbarg



Norval - DN 2" d.375/TR mm

from 90 kPa | 900 mbarg up to 440 kPa | 4400 mbarg
flow capacity table

Norval flow rate (Accuracy 10% ; AC10 according to EN334)											
Inlet pressure		Outlet pressure									
		90 kPa 900 mbarg		150 kPa 1500 mbarg		260 kPa 2600 mbarg		350 kPa 3500 mbarg		440 kPa 4400 mbarg	
MPa	barg	Stm³/h	Scfh	Stm³/h	Scfh	Stm³/h	Scfh	Stm³/h	Scfh	Stm³/h	Scfh
0.05	0.5	-	-	-	-	-	-	-	-	-	-
0.1	1	-	-	-	-	-	-	-	-	-	-
0.2	2	1800	63600	1400	49500	-	-	-	-	-	-
0.4	4	3385	119600	3390	119800	2895	102300	1900	67100	-	-
0.8	8	4715	166600	6055	213900	6060	214100	6165	217800	5575	196900
1	10	4755	168000	6935	245000	7440	262800	7445	263000	7455	263300
1.6	16	5225	184600	6905	243900	9375	331100	11360	401200	11370	401600

CG = 1360 K1= 106.78

Table 34 Norval flow rate with outlet pressure from 90 kPa | 900 mbarg up to 440 kPa | 4400 mbarg

Norval flow rate (Accuracy 20% ; AC20 according to EN334)											
Inlet pressure		Outlet pressure									
		90 kPa 900 mbarg		150 kPa 1500 mbarg		260 kPa 2600 mbarg		350 kPa 3500 mbarg		440 kPa 4400 mbarg	
MPa	barg	Stm³/h	Scfh	Stm³/h	Scfh	Stm³/h	Scfh	Stm³/h	Scfh	Stm³/h	Scfh
0.05	0.5	-	-	-	-	-	-	-	-	-	-
0.1	1	-	-	-	-	-	-	-	-	-	-
0.2	2	2795	98800	2300	81300	-	-	-	-	-	-
0.4	4	4680	165300	5380	190000	4190	148000	3000	106000	-	-
0.8	8	6450	227800	7645	270000	8945	315900	9945	351300	9755	344500
1	10	6635	234400	8420	297400	10910	385300	11915	420800	12420	438700
1.6	16	6605	233300	8675	306400	11845	418400	13830	488500	14830	523800

CG = 1360 K1= 106.78

Table 35 Norval flow rate with outlet pressure from 90 kPa | 900 mbarg up to 440 kPa | 4400 mbarg

Norval - DN 2" 1/2 d.630 mm

from 2.0 kPa | 20 mbarg up to 8 kPa | 80 mbarg

flow capacity table

Norval flow rate (Accuracy 10% ; AC10 according to EN334)											
Inlet pressure		Outlet pressure									
		2.0 kPa 20 mbarg		4 kPa 40 mbarg		5 kPa 50 mbarg		6 kPa 60 mbarg		8 kPa 80 mbarg	
MPa	barg	Stm ³ /h	Scfh	Stm ³ /h	Scfh	Stm ³ /h	Scfh	Stm ³ /h	Scfh	Stm ³ /h	Scfh
0.05	0.5	1400	49500	1450	51300	1450	51300	1450	51300	1400	49500
0.1	1	1800	63600	1900	67100	2095	74000	2145	75800	2095	74000
0.2	2	2095	74000	2195	77600	3190	112700	3190	112700	3290	116200
0.4	4	2190	77400	2290	80900	3485	123100	3285	116100	3780	133500
0.8	8	2380	84100	2480	87600	3670	129700	3570	126100	4065	143600
1	10	2475	87500	2675	94500	3760	132800	3760	132800	4155	146800
1.6	16	2660	94000	3645	128800	3940	139200	4135	146100	4430	156500

CG = 2240 K1= 106.78

Table 36 Norval flow rate with outlet pressure from 2.0 kPa | 20 mbarg up to 8 kPa | 80 mbarg

Norval flow rate (Accuracy 20% ; AC20 according to EN334)											
Inlet pressure		Outlet pressure									
		1.0 kPa 10 mbarg		2 kPa 20 mbarg		4 kPa 40 mbarg		6 kPa 60 mbarg		8 kPa 80 mbarg	
MPa	barg	Stm ³ /h	Scfh	Stm ³ /h	Scfh	Stm ³ /h	Scfh	Stm ³ /h	Scfh	Stm ³ /h	Scfh
0.05	0.5	1550	54800	1550	54800	1550	54800	1500	53000	1500	53000
0.1	1	2295	81100	2295	81100	2295	81100	2245	79300	2245	79300
0.2	2	3190	112700	3190	112700	3540	125100	3540	125100	3540	125100
0.4	4	3285	116100	3285	116100	5870	207300	5870	207300	5870	207300
0.8	8	6045	213500	6045	213500	6145	217100	6295	222400	6395	225900
1	10	6035	213200	6035	213200	6135	216700	6285	222000	6380	225400
1.6	16	5710	201700	5710	201700	6105	215600	6255	220900	6350	224300

CG = 2240 K1= 106.78

Table 37 Norval flow rate with outlet pressure from 2.0 kPa | 20 mbarg up to 8 kPa | 80 mbarg



Norval - DN 2" 1/2 d.495 mm

from 8 kPa | 80 mbarg up to 53 kPa | 530 mbarg
flow capacity table

Norval flow rate (Accuracy 10% ; AC10 according to EN334)											
Inlet pressure		Outlet pressure									
		8 kPa 80 mbarg		20 kPa 200 mbarg		30 kPa 300 mbarg		40 kPa 400 mbarg		53 kPa 530 mbarg	
MPa	barg	Stm³/h	Scfh	Stm³/h	Scfh	Stm³/h	Scfh	Stm³/h	Scfh	Stm³/h	Scfh
0.05	0.5	1400	49500	1050	37100	1050	37100	760	26900	-	-
0.1	1	2095	74000	2100	74200	2050	72400	1925	68000	1800	63600
0.2	2	3290	116200	2990	105600	2995	105800	3325	117500	2995	105800
0.4	4	3780	133500	3980	140600	3980	140600	5225	184600	5675	200500
0.8	8	4065	143600	4955	175000	4760	168100	6330	223600	7240	255700
1	10	4155	146800	5145	181700	4950	174900	6350	224300	7225	255200
1.6	16	4430	156500	5615	198300	6105	215600	6520	230300	7190	254000

CG = 2240 K1 = 106.78

Table 38 Norval flow rate with outlet pressure from 8 kPa | 80 mbarg up to 53 kPa | 530 mbarg

Norval flow rate (Accuracy 20% ; AC20 according to EN334)											
Inlet pressure		Outlet pressure									
		8 kPa 80 mbarg		20 kPa 200 mbarg		30 kPa 300 mbarg		40 kPa 400 mbarg		53 kPa 530 mbarg	
MPa	barg	Stm³/h	Scfh	Stm³/h	Scfh	Stm³/h	Scfh	Stm³/h	Scfh	Stm³/h	Scfh
0.05	0.5	1500	53000	1300	46000	1120	39600	815	28800	-	-
0.1	1	2245	79300	2200	77700	2100	74200	2015	71200	1850	65400
0.2	2	3540	125100	3540	125100	3540	125100	3540	125100	3440	121500
0.4	4	5870	207300	5870	207300	5870	207300	5870	207300	5875	207500
0.8	8	6395	225900	7135	252000	7735	273200	8310	293500	9125	322300
1	10	6380	225400	7125	251700	7720	272700	8300	293200	9105	321600
1.6	16	6350	224300	7090	250400	7685	271400	8260	291700	9065	320200

CG = 2240 K1 = 106.78

Table 39 Norval flow rate with outlet pressure from 8 kPa | 80 mbarg up to 53 kPa | 530 mbarg

Norval - DN 2" 1/2 d.375 mm

from 53 kPa | 530 mbarg up to 260 kPa | 2600 mbarg
flow capacity table

Norval flow rate (Accuracy 10% ; AC10 according to EN334)											
Inlet pressure		Outlet pressure									
		53 kPa 530 mbarg		90 kPa 900 mbarg		150 kPa 1500 mbarg		200 kPa 2000 mbarg		260 kPa 2600 mbarg	
MPa	barg	Stm ³ /h	Scfh	Stm ³ /h	Scfh	Stm ³ /h	Scfh	Stm ³ /h	Scfh	Stm ³ /h	Scfh
0.05	0.5	-	-	-	-	-	-	-	-	-	-
0.1	1	1800	63600	-	-	-	-	-	-	-	-
0.2	2	2995	105800	2995	105800	2350	83000	-	-	-	-
0.4	4	5675	200500	4680	165300	5480	193600	5185	183200	4740	167400
0.8	8	7240	255700	6945	245300	9430	333100	9930	350700	8945	315900
1	10	7225	255200	7425	262300	9910	350000	11895	420100	10910	385300
1.6	16	7190	254000	8475	299300	10845	383000	11835	418000	14805	522900

CG = 2240 K1= 106.78

Table 40 Norval flow rate with outlet pressure from 53 kPa | 530 mbarg up to 260 kPa | 2600 mbarg

Norval flow rate (Accuracy 20% ; AC20 according to EN334)											
Inlet pressure		Outlet pressure									
		53 kPa 530 mbarg		90 kPa 900 mbarg		150 kPa 1500 mbarg		200 kPa 2000 mbarg		260 kPa 2600 mbarg	
MPa	barg	Stm ³ /h	Scfh	Stm ³ /h	Scfh	Stm ³ /h	Scfh	Stm ³ /h	Scfh	Stm ³ /h	Scfh
0.05	0.5	-	-	-	-	-	-	-	-	-	-
0.1	1	1850	65400	-	-	-	-	-	-	-	-
0.2	2	3440	121500	3195	112900	2450	86600	-	-	-	-
0.4	4	5875	207500	5875	207500	5880	207700	5435	192000	4890	172700
0.8	8	9125	322300	10515	371400	10520	371600	10525	371700	10535	372100
1	10	9105	321600	11290	398800	12880	454900	12885	455100	12895	455400
1.6	16	9065	320200	11235	396800	14690	518800	17655	623500	19740	697200

CG = 2240 K1= 106.78

Table 41 Norval flow rate with outlet pressure from 53 kPa | 530 mbarg up to 260 kPa | 2600 mbarg



Norval - DN 2" 1/2 d.375/TR mm

from 90 kPa | 900 mbarg up to 440 kPa | 4400 mbarg
flow capacity table

Norval flow rate (Accuracy 10% ; AC10 according to EN334)											
Inlet pressure		Outlet pressure									
		90 kPa 900 mbarg		150 kPa 1500 mbarg		260 kPa 2600 mbarg		350 kPa 3500 mbarg		440 kPa 4400 mbarg	
MPa	barg	Stm³/h	Scfh	Stm³/h	Scfh	Stm³/h	Scfh	Stm³/h	Scfh	Stm³/h	Scfh
0.05	0.5	-	-	-	-	-	-	-	-	-	-
0.1	1	-	-	-	-	-	-	-	-	-	-
0.2	2	2995	105800	2350	83000	-	-	-	-	-	-
0.4	4	4680	165300	5480	193600	4740	167400	3095	109300	-	-
0.8	8	6945	245300	9430	333100	8945	315900	8950	316100	8960	316500
1	10	7425	262300	9910	350000	10910	385300	10920	385700	10930	386000
1.6	16	8475	299300	10845	383000	14805	522900	17780	627900	17795	628500
CG = 1360 K1= 106.78											

Table 42 Norval flow rate with outlet pressure from 90 kPa | 900 mbarg up to 440 kPa | 4400 mbarg

Norval flow rate (Accuracy 20% ; AC20 according to EN334)											
Inlet pressure		Outlet pressure									
		90 kPa 900 mbarg		150 kPa 1500 mbarg		260 kPa 2600 mbarg		350 kPa 3500 mbarg		440 kPa 4400 mbarg	
MPa	barg	Stm³/h	Scfh	Stm³/h	Scfh	Stm³/h	Scfh	Stm³/h	Scfh	Stm³/h	Scfh
0.05	0.5	-	-	-	-	-	-	-	-	-	-
0.1	1	-	-	-	-	-	-	-	-	-	-
0.2	2	3195	112900	2450	86600	-	-	-	-	-	-
0.4	4	5875	207500	5880	207700	4890	172700	3295	116400	-	-
0.8	8	10515	371400	10520	371600	10535	372100	10545	372400	9805	346300
1	10	11290	398800	12880	454900	12895	455400	12905	455800	12915	456100
1.6	16	11235	396800	14690	518800	19740	697200	19755	697700	19770	698200
CG = 1360 K1= 106.78											

Table 43 Norval flow rate with outlet pressure from 90 kPa | 900 mbarg up to 440 kPa | 4400 mbarg

Norval - DN 3" d.630 mm

from 1.0 kPa | 10 mbarg up to 8 kPa | 80 mbarg

flow capacity table

Norval flow rate (Accuracy 10% ; AC10 according to EN334)											
Inlet pressure		Outlet pressure									
		1.0 kPa 10 mbarg		2 kPa 20 mbarg		4 kPa 40 mbarg		6 kPa 60 mbarg		8 kPa 80 mbarg	
MPa	barg	Stm ³ /h	Scfh	Stm ³ /h	Scfh	Stm ³ /h	Scfh	Stm ³ /h	Scfh	Stm ³ /h	Scfh
0.05	0.5	2200	77700	2200	77700	2200	77700	2200	77700	2150	76000
0.1	1	2895	102300	2895	102300	2995	105800	3195	112900	2995	105800
0.2	2	4985	176100	4985	176100	4985	176100	4685	165500	5120	180900
0.4	4	4975	175700	4975	175700	4975	175700	4875	172200	5470	193200
0.8	8	2975	105100	2975	105100	4955	175000	5155	182100	5945	210000
1	10	2970	104900	2970	104900	4950	174900	5345	188800	6035	213200
1.6	16	2955	104400	2955	104400	5415	191300	5515	194800	6205	219200

CG = 3395 K1= 106.78

Table 44 Norval flow rate with outlet pressure from 1.0 kPa | 10 mbarg up to 8 kPa | 80 mbarg

Norval flow rate (Accuracy 20% ; AC20 according to EN334)											
Inlet pressure		Outlet pressure									
		1.0 kPa 10 mbarg		2 kPa 20 mbarg		4 kPa 40 mbarg		6 kPa 60 mbarg		8 kPa 80 mbarg	
MPa	barg	Stm ³ /h	Scfh	Stm ³ /h	Scfh	Stm ³ /h	Scfh	Stm ³ /h	Scfh	Stm ³ /h	Scfh
0.05	0.5	2400	84800	2400	84800	2300	81300	2250	79500	2650	93600
0.1	1	3495	123500	3495	123500	3445	121700	3395	119900	3395	119900
0.2	2	5285	186700	5285	186700	5335	188500	5335	188500	6030	213000
0.4	4	7460	263500	7460	263500	8855	312800	8855	312800	8855	312800
0.8	8	9120	322100	9120	322100	9315	329000	9515	336100	9715	343100
1	10	9100	321400	9100	321400	9300	328500	9500	335500	9695	342400
1.6	16	9060	320000	9060	320000	9255	326900	9455	334000	9650	340800

CG = 3395 K1= 106.78

Table 45 Norval flow rate with outlet pressure from 1.0 kPa | 10 mbarg up to 8 kPa | 80 mbarg



Norval - DN 3" d.495 mm

from 8 kPa | 80 mbarg up to 53 kPa | 530 mbarg
flow capacity table

Norval flow rate (Accuracy 10% ; AC10 according to EN334)											
Inlet pressure		Outlet pressure									
		8 kPa 80 mbarg		20 kPa 200 mbarg		30 kPa 300 mbarg		40 kPa 400 mbarg		53 kPa 530 mbarg	
MPa	barg	Stm³/h	Scfh	Stm³/h	Scfh	Stm³/h	Scfh	Stm³/h	Scfh	Stm³/h	Scfh
0.05	0.5	2150	76000	1890	66800	1600	56600	1140	40300	-	-
0.1	1	2995	105800	3195	112900	3095	109300	2930	103500	2700	95400
0.2	2	5120	180900	4985	176100	5185	183200	5020	177300	4990	176300
0.4	4	5470	193200	7365	260100	7365	260100	7860	277600	8660	305900
0.8	8	5945	210000	8625	304600	9320	329200	10065	355500	10905	385200
1	10	6035	213200	8610	304100	9305	328700	10045	354800	10890	384600
1.6	16	6205	219200	8570	302700	9260	327100	10000	353200	10835	382700

CG = 3395 K1= 106.78

Table 46 Norval flow rate with outlet pressure from 8 kPa | 80 mbarg up to 53 kPa | 530 mbarg

Norval flow rate (Accuracy 20% ; AC20 according to EN334)											
Inlet pressure		Outlet pressure									
		8 kPa 80 mbarg		20 kPa 200 mbarg		30 kPa 300 mbarg		40 kPa 400 mbarg		53 kPa 530 mbarg	
MPa	barg	Stm³/h	Scfh	Stm³/h	Scfh	Stm³/h	Scfh	Stm³/h	Scfh	Stm³/h	Scfh
0.05	0.5	2650	93600	2000	70700	1700	60100	1215	43000	-	-
0.1	1	3395	119900	3295	116400	3195	112900	3030	107100	2800	98900
0.2	2	6030	213000	5335	188500	5335	188500	5335	188500	5190	183300
0.4	4	8855	312800	8455	298600	8905	314500	8905	314500	8910	314700
0.8	8	9715	343100	10805	381600	11695	413100	11040	389900	13780	486700
1	10	9695	342400	10785	380900	11675	412300	12585	444500	13760	486000
1.6	16	9650	340800	10735	379200	11620	410400	12525	442400	13695	483700

CG = 3395 K1= 106.78

Table 47 Norval flow rate with outlet pressure from 8 kPa | 80 mbarg up to 53 kPa | 530 mbarg

Norval - DN 3" d.375 mm

from 53 kPa | 530 mbarg up to 260 kPa | 2600 mbarg

flow capacity table

Norval flow rate (Accuracy 10% ; AC10 according to EN334)											
Inlet pressure		Outlet pressure									
		53 kPa 530 mbarg		90 kPa 900 mbarg		150 kPa 1500 mbarg		200 kPa 2000 mbarg		260 kPa 2600 mbarg	
MPa	barg	Stm ³ /h	Scfh	Stm ³ /h	Scfh	Stm ³ /h	Scfh	Stm ³ /h	Scfh	Stm ³ /h	Scfh
0.05	0.5	-	-	-	-	-	-	-	-	-	-
0.1	1	2700	95400	-	-	-	-	-	-	-	-
0.2	2	4990	176300	3980	140600	3595	127000	-	-	-	-
0.4	4	8660	305900	6990	246900	8170	288600	7975	281700	7185	253800
0.8	8	10905	385200	10020	353900	13895	490700	14895	526100	13910	491300
1	10	10890	384600	11880	419600	15850	559800	18835	665200	15870	560500
1.6	16	10835	382700	13500	476800	15775	557100	19725	696600	24670	871300

CG = 3395 K1= 106.78

Table 48 Norval flow rate with outlet pressure from 53 kPa | 530 mbarg up to 260 kPa | 2600 mbarg

Norval flow rate (Accuracy 20% ; AC20 according to EN334)											
Inlet pressure		Outlet pressure									
		53 kPa 530 mbarg		90 kPa 900 mbarg		150 kPa 1500 mbarg		200 kPa 2000 mbarg		260 kPa 2600 mbarg	
MPa	barg	Stm ³ /h	Scfh	Stm ³ /h	Scfh	Stm ³ /h	Scfh	Stm ³ /h	Scfh	Stm ³ /h	Scfh
0.05	0.5	-	-	-	-	-	-	-	-	-	-
0.1	1	2800	98900	-	-	-	-	-	-	-	-
0.2	2	5190	183300	4840	171000	3695	130500	-	-	-	-
0.4	4	8910	314700	8910	314700	8920	315100	8225	290500	7435	262600
0.8	8	13780	486700	15870	560500	15980	564400	15985	564600	15995	564900
1	10	13760	486000	17030	601500	19515	689200	19525	689600	19540	690100
1.6	16	13695	483700	16950	598600	22280	786900	26830	947500	30000	1059500

CG = 3395 K1= 106.78

Table 49 Norval flow rate with outlet pressure from 53 kPa | 530 mbarg up to 260 kPa | 2600 mbarg



Norval - DN 3" d.375/TR mm

from 90 kPa | 900 mbarg up to 440 kPa | 4400 mbarg
flow capacity table

Norval flow rate (Accuracy 10% ; AC10 according to EN334)											
Inlet pressure		Outlet pressure									
		90 kPa 900 mbarg		150 kPa 1500 mbarg		260 kPa 2600 mbarg		350 kPa 3500 mbarg		440 kPa 4400 mbarg	
MPa	barg	Stm³/h	Scfh	Stm³/h	Scfh	Stm³/h	Scfh	Stm³/h	Scfh	Stm³/h	Scfh
0.05	0.5	-	-	-	-	-	-	-	-	-	-
0.1	1	-	-	-	-	-	-	-	-	-	-
0.2	2	3980	140600	3595	127000	-	-	-	-	-	-
0.4	4	6990	246900	8170	288600	7185	253800	4795	169400	-	-
0.8	8	10020	353900	13895	490700	13910	491300	15415	544400	14435	509800
1	10	11880	419600	15850	559800	15870	560500	18860	666100	18880	666800
1.6	16	13500	476800	15775	557100	24670	871300	24690	872000	24715	872900
CG = 3395 K1= 106.78											

Table 50 Norval flow rate with outlet pressure from 90 kPa | 900 mbarg up to 440 kPa | 4400 mbarg

Norval flow rate (Accuracy 20% ; AC20 according to EN334)											
Inlet pressure		Outlet pressure									
		90 kPa 900 mbarg		150 kPa 1500 mbarg		260 kPa 2600 mbarg		350 kPa 3500 mbarg		440 kPa 4400 mbarg	
MPa	barg	Stm³/h	Scfh	Stm³/h	Scfh	Stm³/h	Scfh	Stm³/h	Scfh	Stm³/h	Scfh
0.05	0.5	-	-	-	-	-	-	-	-	-	-
0.1	1	-	-	-	-	-	-	-	-	-	-
0.2	2	4840	171000	3695	130500	-	-	-	-	-	-
0.4	4	8910	314700	8920	315100	7435	262600	4995	176400	-	-
0.8	8	15870	560500	15980	564400	15995	564900	16010	565400	14835	523900
1	10	17030	601500	19515	689200	19540	690100	19555	690600	19575	691300
1.6	16	16950	598600	22280	786900	30000	1059500	30025	1060400	30050	1061300
CG = 3395 K1= 106.78											

Table 51 Norval flow rate with outlet pressure from 90 kPa | 900 mbarg up to 440 kPa | 4400 mbarg

Norval - DN 4" d.630 mm

from 2 kPa | 20 mbarg up to 8 kPa | 80 mbarg

flow capacity table

Norval flow rate (Accuracy 10% ; AC10 according to EN334)											
Inlet pressure		Outlet pressure									
		2 kPa 20 mbarg		4 kPa 40 mbarg		5 kPa 50 mbarg		6 kPa 60 mbarg		8 kPa 80 mbarg	
MPa	barg	Stm ³ /h	Scfh	Stm ³ /h	Scfh	Stm ³ /h	Scfh	Stm ³ /h	Scfh	Stm ³ /h	Scfh
0.05	0.5	3295	116400	3195	112900	3295	116400	3295	116400	2995	105800
0.075	0.75	4095	144700	3995	141100	3995	141100	3995	141100	3795	134100
0.1	1	4490	158600	4490	158600	4490	158600	4490	158600	4490	158600
0.2	2	6980	246500	6480	228900	6980	246500	6980	246500	6980	246500
0.4	4	7960	281200	5970	210900	8955	316300	8955	316300	7960	281200
0.6	6	7945	280600	6155	217400	8935	315600	8935	315600	8140	287500
0.8	8	7930	280100	6345	224100	8920	315100	8920	315100	8920	315100

CG = 5100 K1= 106.78

Table 52 Norval flow rate with outlet pressure from 2 kPa | 20 mbarg up to 8 kPa | 80 mbarg

Norval flow rate (Accuracy 20% ; AC20 according to EN334)											
Inlet pressure		Outlet pressure									
		2 kPa 20 mbarg		4 kPa 40 mbarg		5 kPa 50 mbarg		6 kPa 60 mbarg		8 kPa 80 mbarg	
MPa	barg	Stm ³ /h	Scfh	Stm ³ /h	Scfh	Stm ³ /h	Scfh	Stm ³ /h	Scfh	Stm ³ /h	Scfh
0.05	0.5	3395	119900	3395	119900	3395	119900	3295	116400	3295	116400
0.075	0.75	4295	151700	4295	151700	4295	151700	4295	151700	4195	148200
0.1	1	4790	169200	4790	169200	4790	169200	4790	169200	4790	169200
0.2	2	6980	246500	6980	246500	6980	246500	6980	246500	6980	246500
0.4	4	8955	316300	8955	316300	8955	316300	8955	316300	8955	316300
0.6	6	10590	374000	9930	350700	9930	350700	9930	350700	9930	350700
0.8	8	11890	419900	11890	419900	11895	420100	11895	420100	11895	420100

CG = 5100 K1= 106.78

Table 53 Norval flow rate with outlet pressure from 2 kPa | 20 mbarg up to 8 kPa | 80 mbarg



Norval - DN 4" d.495 mm

from 8 kPa | 80 mbarg up to 53 kPa | 530 mbarg
flow capacity table

Norval flow rate (Accuracy 10% ; AC10 according to EN334)											
Inlet pressure		Outlet pressure									
		8 kPa 80 mbarg		15 kPa 150 mbarg		20 kPa 200 mbarg		30 kPa 300 mbarg		53 kPa 530 mbarg	
MPa	barg	Stm ³ /h	Scfh	Stm ³ /h	Scfh	Stm ³ /h	Scfh	Stm ³ /h	Scfh	Stm ³ /h	Scfh
0.05	0.5	2995	105800	2900	102500	2500	88300	2450	86600	-	-
0.075	0.75	3795	134100	3795	134100	3795	134100	3695	130500	2150	76000
0.1	1	4490	158600	4495	158800	4790	169200	4595	162300	3995	141100
0.2	2	6980	246500	6980	246500	6980	246500	6480	228900	7480	264200
0.4	4	7960	281200	7460	263500	8955	316300	7960	281200	9955	351600
0.6	6	8140	287500	7945	280600	9930	350700	8940	315800	11920	421000
0.8	8	8920	315100	8920	315100	10905	385200	9915	350200	12890	455300

CG = 5100 K1= 106.78

Table 54 Norval flow rate with outlet pressure from 8 kPa | 80 mbarg up to 53 kPa | 530 mbarg

Norval flow rate (Accuracy 20% ; AC20 according to EN334)											
Inlet pressure		Outlet pressure									
		8 kPa 80 mbarg		15 kPa 150 mbarg		20 kPa 200 mbarg		30 kPa 300 mbarg		53 kPa 530 mbarg	
MPa	barg	Stm ³ /h	Scfh	Stm ³ /h	Scfh	Stm ³ /h	Scfh	Stm ³ /h	Scfh	Stm ³ /h	Scfh
0.05	0.5	3295	116400	3000	106000	2550	90100	2550	90100	-	-
0.075	0.75	4195	148200	3795	134100	3795	134100	3795	134100	2900	102500
0.1	1	4790	169200	4790	169200	4790	169200	4795	169400	4195	148200
0.2	2	6980	246500	6980	246500	6980	246500	6980	246500	7680	271300
0.4	4	8955	316300	8955	316300	8955	316300	8955	316300	9955	351600
0.6	6	9930	350700	9930	350700	9930	350700	9930	350700	11920	421000
0.8	8	11895	420100	11895	420100	11895	420100	11895	420100	13880	490200

CG = 5100 K1= 106.78

Table 55 Norval flow rate with outlet pressure from 8 kPa | 80 mbarg up to 53 kPa | 530 mbarg

Norval - DN 4" d.375 mm

from 53 kPa | 530 mbarg up to 260 kPa | 2600 mbarg

flow capacity table

Norval flow rate (Accuracy 10% ; AC10 according to EN334)											
Inlet pressure		Outlet pressure									
		53 kPa 530 mbarg		90 kPa 900 mbarg		150 kPa 1500 mbarg		200 kPa 2000 mbarg		260 kPa 2600 mbarg	
MPa	barg	Stm ³ /h	Scfh	Stm ³ /h	Scfh	Stm ³ /h	Scfh	Stm ³ /h	Scfh	Stm ³ /h	Scfh
0.05	0.5	-	-	-	-	-	-	-	-	-	-
0.075	0.75	2150	76000	-	-	-	-	-	-	-	-
0.1	1	3995	141100	-	-	-	-	-	-	-	-
0.2	2	7480	264200	6485	229100	4495	158800	-	-	-	-
0.4	4	9955	351600	10955	386900	11955	422200	11965	422600	8480	299500
0.6	6	11920	421000	12920	456300	17900	632200	17910	632500	14600	515600
0.8	8	12890	455300	14880	525500	20840	736000	18865	666300	19870	701800

CG = 5100 K1= 106.78

Table 56 Norval flow rate with outlet pressure from 53 kPa | 530 mbarg up to 260 kPa | 2600 mbarg

Norval flow rate (Accuracy 20% ; AC20 according to EN334)											
Inlet pressure		Outlet pressure									
		53 kPa 530 mbarg		90 kPa 900 mbarg		150 kPa 1500 mbarg		200 kPa 2000 mbarg		260 kPa 2600 mbarg	
MPa	barg	Stm ³ /h	Scfh	Stm ³ /h	Scfh	Stm ³ /h	Scfh	Stm ³ /h	Scfh	Stm ³ /h	Scfh
0.05	0.5	-	-	-	-	-	-	-	-	-	-
0.075	0.75	2900	102500	-	-	-	-	-	-	-	-
0.1	1	4195	148200	-	-	-	-	-	-	-	-
0.2	2	7680	271300	7285	257300	5495	194100	-	-	-	-
0.4	4	9955	351600	10955	386900	13450	475000	12460	440100	9975	352300
0.6	6	11920	421000	13910	491300	17900	632200	17910	632500	16590	585900
0.8	8	13880	490200	15970	564000	21835	771100	19860	701400	21860	772000

CG = 5100 K1= 106.78

Table 57 Norval flow rate with outlet pressure from 53 kPa | 530 mbarg up to 260 kPa | 2600 mbarg



Norval - DN 4" d.375/TR mm

from 90 kPa | 900 mbarg up to 440 kPa | 4400 mbarg
flow capacity table

Norval flow rate (Accuracy 10% ; AC10 according to EN334)											
Inlet pressure		Outlet pressure									
		90 kPa 900 mbarg		150 kPa 1500 mbarg		260 kPa 2600 mbarg		350 kPa 3500 mbarg		440 kPa 4400 mbarg	
MPa	barg	Stm³/h	Scfh	Stm³/h	Scfh	Stm³/h	Scfh	Stm³/h	Scfh	Stm³/h	Scfh
0.05	0.5	-	-	-	-	-	-	-	-	-	-
0.075	0.75	-	-	-	-	-	-	-	-	-	-
0.1	1	-	-	-	-	-	-	-	-	-	-
0.2	2	6485	229100	4495	158800	-	-	-	-	-	-
0.4	4	10955	386900	11955	422200	8480	299500	5995	211800	-	-
0.6	6	12920	456300	17900	632200	14600	515600	15280	539700	11970	422800
0.8	8	14880	525500	20840	736000	19870	701800	21880	772700	17920	632900

CG = 5100 K1= 106.78

Table 58 Norval flow rate with outlet pressure from 90 kPa | 900 mbarg up to 440 kPa | 4400 mbarg

Norval flow rate (Accuracy 20% ; AC20 according to EN334)											
Inlet pressure		Outlet pressure									
		90 kPa 900 mbarg		150 kPa 1500 mbarg		260 kPa 2600 mbarg		350 kPa 3500 mbarg		440 kPa 4400 mbarg	
MPa	barg	Stm³/h	Scfh	Stm³/h	Scfh	Stm³/h	Scfh	Stm³/h	Scfh	Stm³/h	Scfh
0.05	0.5	-	-	-	-	-	-	-	-	-	-
0.075	0.75	-	-	-	-	-	-	-	-	-	-
0.1	1	-	-	-	-	-	-	-	-	-	-
0.2	2	7285	257300	5495	194100	-	-	-	-	-	-
0.4	4	10955	386900	13450	475000	9975	352300	7390	261000	-	-
0.6	6	13910	491300	17900	632200	16590	585900	17305	611200	14665	517900
0.8	8	15970	564000	21835	771100	21860	772000	23970	846500	22300	787600

CG = 5100 K1= 106.78

Table 59 Norval flow rate with outlet pressure from 90 kPa | 900 mbarg up to 440 kPa | 4400 mbarg

Norval - DN 6" d.817 mm

from 2 kPa | 20 mbarg up to 7 kPa | 70 mbarg

flow capacity table

Norval flow rate (Accuracy 10% ; AC10 according to EN334)											
Inlet pressure		Outlet pressure									
		2 kPa 20 mbarg		3 kPa 30 mbarg		5 kPa 50 mbarg		6 kPa 60 mbarg		7 kPa 70 mbarg	
MPa	barg	Stm ³ /h	Scfh	Stm ³ /h	Scfh	Stm ³ /h	Scfh	Stm ³ /h	Scfh	Stm ³ /h	Scfh
0.05	0.5	6860	242300	6860	242300	6860	242300	6860	242300	6705	236800
0.075	0.75	7790	275200	8725	308200	8730	308300	8415	297200	8415	297200
0.1	1	9035	319100	9350	330200	10285	363300	9970	352100	9970	352100
0.2	2	15560	549500	15560	549500	15870	560500	14625	516500	15250	538600
0.4	4	15530	548500	15530	548500	18635	658100	15220	537500	15840	559400
0.6	6	15500	547400	15500	547400	20145	711500	15810	558400	16740	591200
0.8	8	9285	327900	15470	546400	20110	710200	16090	568300	17635	622800

CG = 10600 K1= 106.78

Table 60 Norval flow rate with outlet pressure from 2 kPa | 20 mbarg up to 7 kPa | 70 mbarg

Norval flow rate (Accuracy 20% ; AC20 according to EN334)											
Inlet pressure		Outlet pressure									
		2 kPa 20 mbarg		3 kPa 30 mbarg		5 kPa 50 mbarg		6 kPa 60 mbarg		7 kPa 70 mbarg	
MPa	barg	Stm ³ /h	Scfh	Stm ³ /h	Scfh	Stm ³ /h	Scfh	Stm ³ /h	Scfh	Stm ³ /h	Scfh
0.05	0.5	7485	264400	7170	253300	8420	297400	7015	247800	7015	247800
0.075	0.75	9040	319300	9040	319300	9040	319300	9040	319300	9040	319300
0.1	1	10905	385200	10595	374200	10595	374200	10595	374200	10595	374200
0.2	2	16495	582600	16650	588000	16650	588000	16650	588000	16650	588000
0.4	4	23290	822500	21740	767800	27640	976100	27640	976100	27640	976100
0.6	6	26035	919500	27275	963300	29445	1039900	29755	1050800	30065	1061800
0.8	8	28465	1005300	28775	1016200	29395	1038100	29700	1048900	30010	1059800

CG = 10600 K1= 106.78

Table 61 Norval flow rate with outlet pressure from 2 kPa | 20 mbarg up to 7 kPa | 70 mbarg



Norval - DN 6" d.658 mm

from 8 kPa | 80 mbarg up to 30 kPa | 300 mbarg
flow capacity table

Norval flow rate (Accuracy 10% ; AC10 according to EN334)

Inlet pressure		Outlet pressure									
		8 kPa 80 mbarg		9 kPa 90 mbarg		15 kPa 150 mbarg		20 kPa 200 mbarg		30 kPa 300 mbarg	
MPa	barg	Stm³/h	Scfh	Stm³/h	Scfh	Stm³/h	Scfh	Stm³/h	Scfh	Stm³/h	Scfh
0.05	0.5	6705	236800	6705	236800	6240	220400	5895	208200	4990	176300
0.075	0.75	8415	297200	8415	297200	7795	275300	7795	275300	7485	264400
0.1	1	9350	330200	9350	330200	9350	330200	9975	352300	9665	341400
0.2	2	15985	564600	14300	505100	14940	527700	15565	549700	16190	571800
0.4	4	17080	603200	16955	598800	19255	680000	22985	811800	22985	811800
0.6	6	17670	624100	17410	614900	19840	700700	24800	875900	25425	897900
0.8	8	18565	655700	15940	563000	20425	721400	26920	950700	29090	1027400

CG = 10600 K1= 106.78

Table 62 Norval flow rate with outlet pressure from 8 kPa | 80 mbarg up to 30 kPa | 300 mbarg

Norval flow rate (Accuracy 20% ; AC20 according to EN334)

Inlet pressure		Outlet pressure									
		8 kPa 80 mbarg		9 kPa 90 mbarg		15 kPa 150 mbarg		20 kPa 200 mbarg		30 kPa 300 mbarg	
MPa	barg	Stm³/h	Scfh	Stm³/h	Scfh	Stm³/h	Scfh	Stm³/h	Scfh	Stm³/h	Scfh
0.05	0.5	8265	291900	8110	286500	6550	231400	6240	220400	5305	187400
0.075	0.75	8885	313800	8885	313800	8730	308300	8420	297400	7950	280800
0.1	1	10595	374200	10595	374200	10440	368700	10285	363300	9975	352300
0.2	2	18830	665000	17275	610100	16650	588000	16655	588200	16655	588200
0.4	4	27640	976100	20340	718400	27795	981600	27955	987300	27800	981800
0.6	6	30375	1072700	30685	1083700	32240	1138600	33790	1193300	36585	1292000
0.8	8	30320	1070800	30630	1081700	32180	1136500	33730	1191200	36520	1289700

CG = 10600 K1= 106.78

Table 63 Norval flow rate with outlet pressure from 8 kPa | 80 mbarg up to 30 kPa | 300 mbarg

Norval - DN 6" d.630 mm

from 22 kPa | 220 mbarg up to 65 kPa | 650 mbarg

flow capacity table

Norval flow rate (Accuracy 10% ; AC10 according to EN334)											
Inlet pressure		Outlet pressure									
		22 kPa 220 mbarg		30 kPa 300 mbarg		42 kPa 420 mbarg		53 kPa 530 mbarg		60 kPa 600 mbarg	
MPa	barg	Stm ³ /h	Scfh	Stm ³ /h	Scfh	Stm ³ /h	Scfh	Stm ³ /h	Scfh	Stm ³ /h	Scfh
0.05	0.5	5723	202000	4996	176400	3278	115700	-	-	-	-
0.075	0.75	7747	273500	7493	264500	6587	232500	5682	200600	5819	205400
0.1	1	9933	350700	9679	341700	9054	319600	8430	297600	7370	260200
0.2	2	15743	555800	16236	573200	15611	551200	15611	551200	14810	522900
0.4	4	23115	816100	23105	815800	24978	881900	27163	959100	25232	890900
0.6	6	25115	886800	25602	904000	31222	1102400	34345	1212700	32746	1156200
0.8	8	27613	975000	29349	1036300	32159	1135500	34345	1212700	34376	1213800

CG = 10600 K1= 106.78

Table 64 Norval flow rate with outlet pressure from 22 kPa | 220 mbarg up to 65 kPa | 650 mbarg

Norval flow rate (Accuracy 20% ; AC20 according to EN334)											
Inlet pressure		Outlet pressure									
		22 kPa 220 mbarg		30 kPa 300 mbarg		42 kPa 420 mbarg		53 kPa 530 mbarg		65 kPa 650 mbarg	
MPa	barg	Stm ³ /h	Scfh	Stm ³ /h	Scfh	Stm ³ /h	Scfh	Stm ³ /h	Scfh	Stm ³ /h	Scfh
0.05	0.5	6050	213700	5305	187400	-	-	-	-	-	-
0.075	0.75	8325	294000	7950	280800	6790	239800	9240	326400	10020	353900
0.1	1	10225	361100	9975	352300	9355	330400	10760	380000	10885	384500
0.2	2	16655	588200	16655	588200	16655	588200	16785	592800	16750	591600
0.4	4	27925	986200	27800	981800	27805	982000	27810	982200	27815	982300
0.6	6	34350	1213100	36585	1292000	38760	1368800	38765	1369000	38770	1369200
0.8	8	34285	1210800	36520	1289700	39925	1410000	43025	1519500	46425	1639500

CG = 10600 K1= 106.78

Table 65 Norval flow rate with outlet pressure from 22 kPa | 220 mbarg up to 65 kPa | 650 mbarg



Norval - DN 6" d.495 mm

from 42 kPa | 420 mbarg up to 150 kPa | 1500 mbarg

flow capacity table

Norval flow rate (Accuracy 10% ; AC10 according to EN334)											
Inlet pressure		Outlet pressure									
		42 kPa 420 mbarg		76 kPa 760 mbarg		90 kPa 900 mbarg		120 kPa 1200 mbarg		150 kPa 1500 mbarg	
MPa	barg	Stm³/h	Scfh	Stm³/h	Scfh	Stm³/h	Scfh	Stm³/h	Scfh	Stm³/h	Scfh
0.05	0.5	-	-	-	-	-	-	-	-	-	-
0.075	0.75	6585	232600	-	-	-	-	-	-	-	-
0.1	1	9040	319300	6380	225400	-	-	-	-	-	-
0.2	2	15570	549900	14015	495000	12415	438500	13090	462300	11225	396500
0.4	4	24855	877800	23310	823200	21815	770400	24875	878500	25505	900800
0.6	6	31005	1095000	31020	1095500	26370	931300	37240	1315200	37250	1315500
0.8	8	31880	1125900	34060	1202900	31275	1104500	37170	1312700	43380	1532000

CG = 10600 K1= 106.78

Table 66 Norval flow rate with outlet pressure from 42 kPa | 420 mbarg up to 150 kPa | 1500 mbarg

Norval flow rate (Accuracy 20% ; AC20 according to EN334)											
Inlet pressure		Outlet pressure									
		42 kPa 420 mbarg		76 kPa 760 mbarg		90 kPa 900 mbarg		120 kPa 1200 mbarg		150 kPa 1500 mbarg	
MPa	barg	Stm³/h	Scfh	Stm³/h	Scfh	Stm³/h	Scfh	Stm³/h	Scfh	Stm³/h	Scfh
0.05	0.5	-	-	-	-	-	-	-	-	-	-
0.075	0.75	6790	239800	-	-	-	-	-	-	-	-
0.1	1	9355	330400	10995	388300	-	-	-	-	-	-
0.2	2	16655	588200	16725	590700	16720	590500	16715	590300	16730	590900
0.4	4	27805	982000	27815	982300	27820	982500	27830	982900	27840	983200
0.6	6	38760	1368800	38775	1369400	38780	1369600	38795	1370100	38805	1370400
0.8	8	39925	1410000	49540	1749500	49855	1760700	49870	1761200	49885	1761700

CG = 10600 K1= 106.78

Table 67 Norval flow rate with outlet pressure from 42 kPa | 420 mbarg up to 150 kPa | 1500 mbarg

Norval - DN 8" d.817 mm

from 2 kPa | 20 mbarg up to 7 kPa | 70 mbarg

flow capacity table

Norval flow rate (Accuracy 10% ; AC10 according to EN334)											
Inlet pressure		Outlet pressure									
		2 kPa 20 mbarg		3 kPa 30 mbarg		5 kPa 50 mbarg		6 kPa 60 mbarg		7 kPa 70 mbarg	
MPa	barg	Stm ³ /h	Scfh	Stm ³ /h	Scfh	Stm ³ /h	Scfh	Stm ³ /h	Scfh	Stm ³ /h	Scfh
0.05	0.5	10740	379300	10740	379300	10740	379300	10740	379300	10500	370900
0.075	0.75	12200	430900	13665	482600	13665	482600	13180	465500	13180	465500
0.1	1	14150	499800	14640	517100	16100	568600	15615	551500	15615	551500
0.2	2	24365	860500	24365	860500	24855	877800	22905	808900	23880	843400
0.4	4	24315	858700	24315	858700	29180	1030500	23830	841600	24805	876000
0.6	6	24270	857100	24270	857100	31550	1114200	24755	874300	26210	925600
0.8	8	14535	513300	24225	855500	31495	1112300	25195	889800	27620	975400

CG = 16600 K1= 106.78

Table 68 Norval flow rate with outlet pressure from 2 kPa | 20 mbarg up to 7 kPa | 70 mbarg

Norval flow rate (Accuracy 20% ; AC20 according to EN334)											
Inlet pressure		Outlet pressure									
		2 kPa 20 mbarg		3 kPa 30 mbarg		5 kPa 50 mbarg		6 kPa 60 mbarg		7 kPa 70 mbarg	
MPa	barg	Stm ³ /h	Scfh	Stm ³ /h	Scfh	Stm ³ /h	Scfh	Stm ³ /h	Scfh	Stm ³ /h	Scfh
0.05	0.5	11720	413900	11230	396600	13185	465700	10985	388000	10985	388000
0.075	0.75	14155	499900	14155	499900	14155	499900	14155	499900	14155	499900
0.1	1	17075	603000	16590	585900	16590	585900	16590	585900	16590	585900
0.2	2	25830	912200	26070	920700	26075	920900	26075	920900	26075	920900
0.4	4	36470	1288000	34040	1202200	43280	1528500	43280	1528500	43285	1528600
0.6	6	40770	1439800	42715	1508500	46110	1628400	46595	1645500	47085	1662800
0.8	8	44575	1574200	45060	1591300	46030	1625600	46515	1642700	47000	1659800

CG = 16600 K1= 106.78

Table 69 Norval flow rate with outlet pressure from 2 kPa | 20 mbarg up to 7 kPa | 70 mbarg



Norval - DN 8" d.658 mm

from 8 kPa | 80 mbarg up to 30 kPa | 300 mbarg

flow capacity table

Norval flow rate (Accuracy 10% ; AC10 according to EN334)											
Inlet pressure		Outlet pressure									
		8 kPa 80 mbarg		9 kPa 90 mbarg		15 kPa 150 mbarg		20 kPa 200 mbarg		30 kPa 300 mbarg	
MPa	barg	Stm ³ /h	Scfh	Stm ³ /h	Scfh	Stm ³ /h	Scfh	Stm ³ /h	Scfh	Stm ³ /h	Scfh
0.05	0.5	10500	370900	10500	370900	9765	344900	9230	326000	7815	276000
0.075	0.75	13180	465500	13180	465500	12205	431100	12205	431100	11720	413900
0.1	1	14640	517100	14640	517100	14640	517100	15615	551500	15130	534400
0.2	2	25030	884000	22395	790900	23395	826200	24370	860700	25350	895300
0.4	4	26750	944700	26550	937700	30155	1065000	35995	1271200	36000	1271400
0.6	6	27670	977200	27265	962900	31070	1097300	38835	1371500	39810	1405900
0.8	8	29070	1026600	24960	881500	31980	1129400	42160	1488900	45555	1608800

CG = 16600 K1= 106.78

Table 70 Norval flow rate with outlet pressure from 8 kPa | 80 mbarg up to 30 kPa | 300 mbarg

Norval flow rate (Accuracy 20% ; AC20 according to EN334)											
Inlet pressure		Outlet pressure									
		8 kPa 80 mbarg		9 kPa 90 mbarg		15 kPa 150 mbarg		20 kPa 200 mbarg		30 kPa 300 mbarg	
MPa	barg	Stm ³ /h	Scfh	Stm ³ /h	Scfh	Stm ³ /h	Scfh	Stm ³ /h	Scfh	Stm ³ /h	Scfh
0.05	0.5	12940	457000	12695	448400	10255	362200	9770	345100	8305	293300
0.075	0.75	13910	491300	13910	491300	13670	482800	13180	465500	12450	439700
0.1	1	16590	585900	16590	585900	16350	577400	16105	568800	15620	551700
0.2	2	29485	1041300	27050	955300	26075	920900	26080	921100	26080	921100
0.4	4	43285	1528600	31855	1125000	43530	1537300	43775	1546000	43535	1537500
0.6	6	47570	1680000	48055	1697100	50485	1782900	52915	1868700	57290	2023200
0.8	8	47485	1677000	47970	1694100	50395	1779700	52820	1865400	57185	2019500

CG = 16600 K1= 106.78

Table 71 Norval flow rate with outlet pressure from 8 kPa | 80 mbarg up to 30 kPa | 300 mbarg

Norval - DN 8" d.630 mm

from 22 kPa | 220 mbarg up to 65 kPa | 650 mbarg

flow capacity table

Norval flow rate (Accuracy 10% ; AC10 according to EN334)											
Inlet pressure		Outlet pressure									
		22 kPa 220 mbarg		30 kPa 300 mbarg		42 kPa 420 mbarg		53 kPa 530 mbarg		65 kPa 650 mbarg	
MPa	barg	Stm ³ /h	Scfh	Stm ³ /h	Scfh	Stm ³ /h	Scfh	Stm ³ /h	Scfh	Stm ³ /h	Scfh
0.05	0.5	8950	316100	7815	276000	-	-	-	-	-	-
0.075	0.75	12110	427700	11720	413900	10305	364000	13710	484200	14890	525900
0.1	1	15520	548100	15130	534400	14160	500100	16250	573900	16310	576000
0.2	2	24570	867700	25350	895300	24380	861000	25275	892600	24385	861200
0.4	4	35995	1271200	36000	1271400	38920	1374500	42335	1495100	39290	1387600
0.6	6	39030	1378400	39810	1405900	48560	1714900	53420	1886600	50895	1797400
0.8	8	42840	1512900	45555	1608800	49925	1763100	53325	1883200	53330	1883400

CG = 16600 K1= 106.78

Table 72 Norval flow rate with outlet pressure from 22 kPa | 220 mbarg up to 65 kPa | 650 mbarg

Norval flow rate (Accuracy 20% ; AC20 according to EN334)											
Inlet pressure		Outlet pressure									
		22 kPa 220 mbarg		30 kPa 300 mbarg		40 kPa 400 mbarg		50 kPa 500 mbarg		65 kPa 650 mbarg	
MPa	barg	Stm ³ /h	Scfh	Stm ³ /h	Scfh	Stm ³ /h	Scfh	Stm ³ /h	Scfh	Stm ³ /h	Scfh
0.05	0.5	9475	334700	8305	293300	5945	210000	-	-	-	-
0.075	0.75	13035	460400	12450	439700	10940	386400	13425	474100	15690	554100
0.1	1	16010	565400	15620	551700	14810	523100	16250	573900	17040	601800
0.2	2	26080	921100	26080	921100	26085	921200	26230	926400	26235	926500
0.4	4	43730	1544400	43535	1537500	43540	1537700	43545	1537800	43555	1538200
0.6	6	53790	1899600	57290	2023200	60130	2123500	60705	2143800	60715	2144200
0.8	8	53695	1896300	57185	2019500	61635	2176700	66055	2332800	72700	2567400

CG = 16600 K1= 106.78

Table 73 Norval flow rate with outlet pressure from 22 kPa | 220 mbarg up to 65 kPa | 650 mbarg



Norval - DN 8" d.495 mm

from 42 kPa | 420 mbarg up to 150 kPa | 1500 mbarg
flow capacity table

Norval flow rate (Accuracy 10% ; AC10 according to EN334)											
Inlet pressure		Outlet pressure									
		42 kPa 420 mbarg		76 kPa 760 mbarg		90 kPa 900 mbarg		120 kPa 1200 mbarg		150 kPa 1500 mbarg	
MPa	barg	Stm³/h	Scfh	Stm³/h	Scfh	Stm³/h	Scfh	Stm³/h	Scfh	Stm³/h	Scfh
0.05	0.5	-	-	-	-	-	-	-	-	-	-
0.075	0.75	10305	364000	-	-	-	-	-	-	-	-
0.1	1	14160	500100	16360	577800	-	-	-	-	-	-
0.2	2	24380	861000	23570	832400	21515	759800	24985	882400	25495	900400
0.4	4	38920	1374500	36505	1289200	34165	1206600	38955	1375700	39945	1410700
0.6	6	48560	1714900	48575	1715500	41295	1458400	58320	2059600	58335	2060100
0.8	8	49925	1763100	53335	1883600	48980	1729800	58210	2055700	67935	2399200

CG = 16600 K1= 106.78

Table 74 Norval flow rate with outlet pressure from 42 kPa | 420 mbarg up to 180 kPa | 1500 mbarg

Norval flow rate (Accuracy 20% ; AC20 according to EN334)											
Inlet pressure		Outlet pressure									
		42 kPa 420 mbarg		76 kPa 760 mbarg		90 kPa 900 mbarg		120 kPa 1200 mbarg		150 kPa 1500 mbarg	
MPa	barg	Stm³/h	Scfh	Stm³/h	Scfh	Stm³/h	Scfh	Stm³/h	Scfh	Stm³/h	Scfh
0.05	0.5	-	-	-	-	-	-	-	-	-	-
0.075	0.75	10635	375600	-	-	-	-	-	-	-	-
0.1	1	14645	517200	17220	608200	-	-	-	-	-	-
0.2	2	26085	921200	26185	924800	26180	924600	26170	924200	26200	925300
0.4	4	43545	1537800	43560	1538400	43570	1538700	43585	1539200	43600	1539800
0.6	6	60700	2143700	60720	2144400	60730	2144700	60750	2145400	60770	2146100
0.8	8	62525	2208100	77580	2739800	78075	2757200	78100	2758100	78120	2758800

CG = 16600 K1= 106.78

Table 75 Norval flow rate with outlet pressure from 42 kPa | 420 mbarg up to 180 kPa | 1500 mbarg



**Pietro
Fiorentini**



Pietro Fiorentini

TB0020ENG



The data are not binding. We reserve the right
to make changes without prior notice.

norval_technicalbrochure_ENG_revN

www.fiorentini.com