

AQUALOG T-CNT

RTU for water mains monitoring



Revision C - Edition 05/2026

**USE, MAINTENANCE
AND WARNING MANUAL**

PAGE INTENTIONALLY LEFT BLANK

1 - INTRODUCTION

FOREWORD

All rights reserved. No part of this publication may be reproduced, distributed, translated into other languages or transmitted by any electronic or mechanical media, including photocopies, recording or any other storage and retrieval system, for any other purposes that are not exclusively the personal use of the buyer, without the express written permission of the Manufacturer.

The manufacturer is in no way responsible for the consequences of operations carried out in a manner not in accordance with the manual.

GENERAL REMARKS

All operating, maintenance instructions and recommendations described in this manual must be followed to in order to:

- obtain the best possible performance from the equipment;
- keep the equipment in efficient conditions.

Training the personnel in charge is essential in order to:

- use and service the equipment properly;
- correctly apply the safety alerts and procedures recommended.

PAGE INTENTIONALLY LEFT BLANK

1.1 - REVISION HISTORY

Revision index	Date
A	01/2025
B	06/2025
C	05/2026

Tab. 1.1.

INDEX

1 - INTRODUCTION	3
1.1 - REVISION HISTORY.....	5
2 - GENERAL INFORMATION	11
2.1 - MANUFACTURER IDENTIFICATION	11
2.1 - IDENTIFICATION OF THE PRODUCT	11
2.2 - REGULATORY FRAMEWORK.....	11
2.3 - WARRANTY	11
2.3.1 - REFERENCE OPERATING CONDITIONS	12
2.4 - ADDRESSEES, SUPPLY AND STORAGE OF THE MANUAL.....	12
2.5 - LANGUAGE	13
2.6 - SYMBOLS USED IN THE MANUAL.....	13
2.7 - APPLIED RATING PLATES	14
2.7.1 - DESCRIPTION OF THE NAMEPLATE.....	15
2.8 - GLOSSARY OF UNITS OF MEASUREMENT	16
2.9 - QUALIFIED PROFESSIONAL FIGURES.....	17
3 - SAFETY	19
3.1 - GENERAL SAFETY WARNINGS.....	19
3.1.1 - SAFETY INSTRUCTIONS FOR INSTALLATION.....	20
3.2 - PERSONAL PROTECTIVE EQUIPMENT.....	21
3.3 - OBLIGATIONS AND PROHIBITIONS	22
3.4 - RESIDUAL RISKS	22
3.5 - SAFETY PICTOGRAMS	23
3.6 - NOISE LEVEL	23

4 - DESCRIPTION AND OPERATION 25

4.1 - GENERAL DESCRIPTION	25
4.2 - POWER SUPPLY DEVICES	27
4.2.1 - BATTERIES	27
4.2.2 - CONNECTORS	28
4.2.2.1 - CABLE GLAND VERSION	28
4.3 - INTENDED USE	29
4.3.1 - ENVISAGED USE	29
4.3.2 - REASONABLY FORESEEABLE MISUSE	29
4.4 - TECHNICAL DATA	30
4.5 - I/O CHANNELS	31
4.6 - DATA COMMUNICATION	31
4.7 - ANTENNAS	31
4.8 - WIRING	32
4.8.1 - ANALOGUE PRESSURE INPUTS	32
4.8.2 - ANALOGUE TEMPERATURE INPUTS	33
4.8.3 - DIGITAL INPUTS	35
4.9 - 4-20 MA / 0÷10V ANALOG INPUTS	36
4.9.1 - DIGITAL OUTPUTS	37
4.10 -ADJUSTMENT WITH SOLENOIDS' WIRING DIAGRAM	38
4.10.1 -PRESSURE REGULATION	38
4.10.2 -MODULATION DAY / NIGHT BY A HYDRAULIC VALVE (DIGITAL OUTPUTS)	38

5 - USER INTERFACE 39

5.1 - LOCAL COMMUNICATION INTERFACE	39
5.1.1 - COMMUNICATION INTERFACE VIA WI-FI	39

6 - TRANSPORT AND HANDLING 41

6.1 - SPECIFIC WARNINGS FOR TRANSPORT AND HANDLING	41
6.1.1 - PACKAGING AND FASTENERS USED FOR TRANSPORT	41
6.2 - PACKAGING CONTENT	42
6.3 - PHYSICAL CHARACTERISTICS OF THE DEVICE	43
6.3.1 - CABLE GLAND VERSION	43
6.4 - EQUIPMENT ANCHORING AND LIFTING METHOD	44
6.4.1 - FORKLIFT HANDLING METHOD	45
6.5 - PACKAGING REMOVAL	47
6.5.1 - PACKAGING DISPOSAL	47
6.6 - STORAGE AND ENVIRONMENTAL CONDITIONS	48
6.6.1 - STORAGE OF THE SPARE BATTERIES	48

7 - INSTALLATION 49

7.1 - GENERAL WARNINGS	49
7.2 - INSTALLATION PRE-REQUISITES.....	49
7.2.1 - ALLOWED ENVIRONMENTAL CONDITIONS.....	49
7.3 - CHECKS BEFORE INSTALLATION.....	50
7.4 - INSTALLATION PROCEDURE	51
7.4.1 - EQUIPMENT ASSEMBLY AND SIM INSERTION.....	51
7.5 - MOUNTING AND CABLING	53
7.5.1 - MOUNTING.....	53
7.5.2 - CONNECTING CABLES I/O	53

8 - CONFIGURATION 57

8.1 - SAFETY REQUIREMENTS FOR CONFIGURATION	57
8.2 - EQUIPMENT CONFIGURATION	57
8.2.1 - STARTING THE RAINBOW SOFTWARE.....	58
8.2.2 - OPENING THE DATABASE.....	59
8.3 - RTU INTERFACE.....	61
8.3.1 - ANALOGUE INPUTS	62
8.3.2 - DIGITAL INPUTS	63
8.3.2.1 - UPDATING METERS.....	64
8.3.3 - DATALOGGER	65
8.3.4 - ENABLING ALARMS ON INPUTS	66
8.4 - CONFIGURATION OF 2G/3G COMMUNICATION PARAMETERS.....	67
8.5 - LOCAL COMMUNICATION	68
8.6 - BATTERY UPGRADE	69
8.7 - ALARM ACTION	70
8.7.1 - ADDING AN ALARM ACTION.....	70
8.8 - 2G, 3G DATA CALL COMMUNICATION TEST.....	72
8.9 - RESET	73

9 - MAINTENANCE AND FUNCTIONAL CHECKS..... 75

9.1 - GENERAL WARNINGS	75
9.2 - SPECIAL MAINTENANCE	76
9.2.1 - REPLACING THE BATTERIES.....	76

10 - UNINSTALLATION AND DISPOSAL 79

10.1 -GENERAL SAFETY WARNINGS.....	79
10.2 -QUALIFICATION OF THE OPERATORS IN CHARGE.....	79
10.3 -INFORMATION REQUIRED IN CASE OF NEW INSTALLATION.....	79
10.4 -STORAGE OF THE BATTERIES	79
10.5 -INFORMATION REQUIRED IN CASE OF RE-INSTALLATION.....	79
10.6 -DISPOSAL INFORMATION.....	80
10.7 - DISPOSING OF THE BATTERIES.....	81
10.7.1 - BATTERY PACKAGING	81

11 - RECOMMENDED SPARE PARTS 83

11.1 -GENERAL WARNINGS	83
11.2 -HOW TO REQUEST SPARE PARTS.....	83
11.3 -PUTTING BACK BATTERIES.....	83

PAGE INTENTIONALLY LEFT BLANK

2 - GENERAL INFORMATION

2.1 - MANUFACTURER IDENTIFICATION

Manufacturer	PIETRO FIORENTINI S.P.A.
Address	Via Enrico Fermi, 8/10 36057 Arcugnano (VI) - ITALY Tel. +39 0444 968511 Fax +39 0444 960468 www.fiorentini.com sales@fiorentini.com

Tab. 2.2.

2.1 - IDENTIFICATION OF THE PRODUCT

Equipment	RTU FOR WATER MAINS MONITORING
Series	AQUALOG T-CNT
Models	<ul style="list-style-type: none"> • AQUALOG T-CNT - version with cable glands • AQUALOG T-CNT - version with MIL connector

Tab. 2.3.

2.2 - REGULATORY FRAMEWORK

PIETRO FIORENTINI S.P.A. with registered office in Arcugnano (Italy) - Via E. Fermi, 8/10, declares that the equipment of the series described in this manual is designed, manufactured, tested and checked in compliance with:

- the requirements of the Directives:
 - 2014/53/EU "RED"
 - 2014/30/EU 'EMC'

NOTICE!

For specific type approvals, see the appropriate section on the Manufacturer's website:
<https://www.fiorentini.com>

NOTICE!

The declaration of conformity in its original version is delivered together with the equipment.

2.3 - WARRANTY

PIETRO FIORENTINI S.P.A. guarantees that the equipment was manufactured using the best materials, with high quality workmanship, and complies with the quality requirements, specifications and performance set out in the order.

The warranty shall be considered null and void and PIETRO FIORENTINI S.P.A. shall not be liable for any damage and/or malfunctions:

- due to any acts or omissions of the purchaser or end-user, or any of their carriers, employees, agents, or any third party or entity;
- in the event that the purchaser, or a third party, makes changes to the equipment supplied by PIETRO FIORENTINI S.P.A. without the prior written approval of the latter;
- in the event of failure by the purchaser to comply with the instructions contained in this manual, as provided by PIETRO FIORENTINI S.P.A.

NOTICE!

The warranty conditions are specified in the commercial contract.

2.3.1 - REFERENCE OPERATING CONDITIONS

The reference operating conditions for battery life calculations are described in Tab. 2.4:

Condition operational	Reference indications
Local interface	10 minutes per month (local interface).
	10 minutes per month (Display).
Sensor acquisition	<ul style="list-style-type: none"> • 1 piezoresistive sensor • 1 meter • 1 transmission per day
Upgrade firmware code	1 time every 5 years.
Communication	1 data transmission per day.

Tab. 2.4.

Ambient temperature has an effect on battery life. The operating profile used to calculate the battery life expectancy is indicated in Tab. 2.5:

	Reference indications
Temperature environment	0.3% of the time at +25 °C
	0.5% of the time at -20 °C
	2.6% of the time at -10 °C
	41.0% of the time at +5 °C
	43.0% of the time at +20 °C
	11.8% of the time at +35 °C
	0.5% of the time at +50 °C
	0.4% of the time at +60 °C

Tab. 2.5.

2.4 - ADDRESSEES, SUPPLY AND STORAGE OF THE MANUAL

The instruction manual is intended for qualified technicians responsible for operating and managing the equipment throughout its service life.

It contains the necessary information to properly use the equipment and keep its functional and qualitative characteristics unchanged over time. All information and warnings for safe, correct use are also provided.

The manual, as well as the declaration of conformity and/or test certificate, is an integral part of the equipment and must always accompany it whenever it is moved or resold. It is the responsibility of the qualified professionals (see paragraph 2.10) to use and manage the equipment.

WARNING!

**Removing, rewriting or editing the pages of the manual and their contents is not allowed.
PIETRO FIORENTINI S.p.A. shall not be held liable for any damage to people, animals and property caused by failure to adhere to the warnings and operating procedures described in this manual.**

2.5 - LANGUAGE

The original instruction manual was drawn up in Italian.

Any translations into additional languages are to be made from the original instruction manual.

HAZARD!

The translations into other languages cannot be fully verified. If any inconsistency is found, please refer to the text of the original manual.





If inconsistencies are found or the text does not make sense:

- stop any actions;
- immediately contact PIETRO FIORENTINI S.p.A. at the addresses specified in paragraph 2.1 (“Identification of the manufacturer”).

WARNING!

PIETRO FIORENTINI S.p.A. shall be held liable for the information provided in the original manual only.

2.6 - SYMBOLS USED IN THE MANUAL

Symbol	Definition
	Symbol used to identify important warnings for the health and safety of the operator or safety of the equipment.
	Symbol used to identify an ELECTRICAL HAZARD to the health and safety of the operator.
	Symbol used to identify information of particular importance in the instruction manual. The information may also concern the safety of the personnel involved in using the equipment.
	Obligation to consult the instruction manual/booklet. Indicates a requirement for the personnel to refer to (and understand) the operating and warning instructions of the machine before working with or on it.

Tab. 2.6.

HAZARD!

Alerts to a hazard with a high level of risk, an imminent hazardous situation which, if not prevented, will result in death or severe damage.

WARNING!

Alerts to a hazard with a medium level of risk, a potentially hazardous situation which, if not prevented, may result in death or severe damage.

ATTENTION!

Alerts to a hazard with a low level of risk, a potentially hazardous situation which, if not prevented, could result in minor or moderate damage.

NOTICE!

Alerts to specific warnings, directions or notes of particular concern, that are not related to physical injury, as well as practices for which physical injury is not likely to occur.

2.7 - APPLIED RATING PLATES

The equipment is equipped with nameplates.

The rating plate contains the identification details of the equipment and its accessories to be cited in case of need to PIETRO FIORENTINI S.p.A.

Id.	Type of plate	Image
1	AQUALOG T-CNT	

Tab. 2.7.

WARNING!

Removing nameplates and/or replacing them with other plates is strictly not allowed.
Should the plates be unintentionally damaged or removed, the customer must notify
PIETRO FIORENTINI S.p.A.

2.7.1 - DESCRIPTION OF THE NAMEPLATE

The following information, described in Tab. 2.8, is shown on the nameplate:

Pos.	Description
1	Fast Logo
2	Manufacturer's Address
3	Equipment model
4	Equipment overhaul status
5	Serial Number
6	Power supply voltage
7	Average power consumption
8	Maximum peak current
9	Safety pictogram
10	CE Marking

Tab. 2.8.

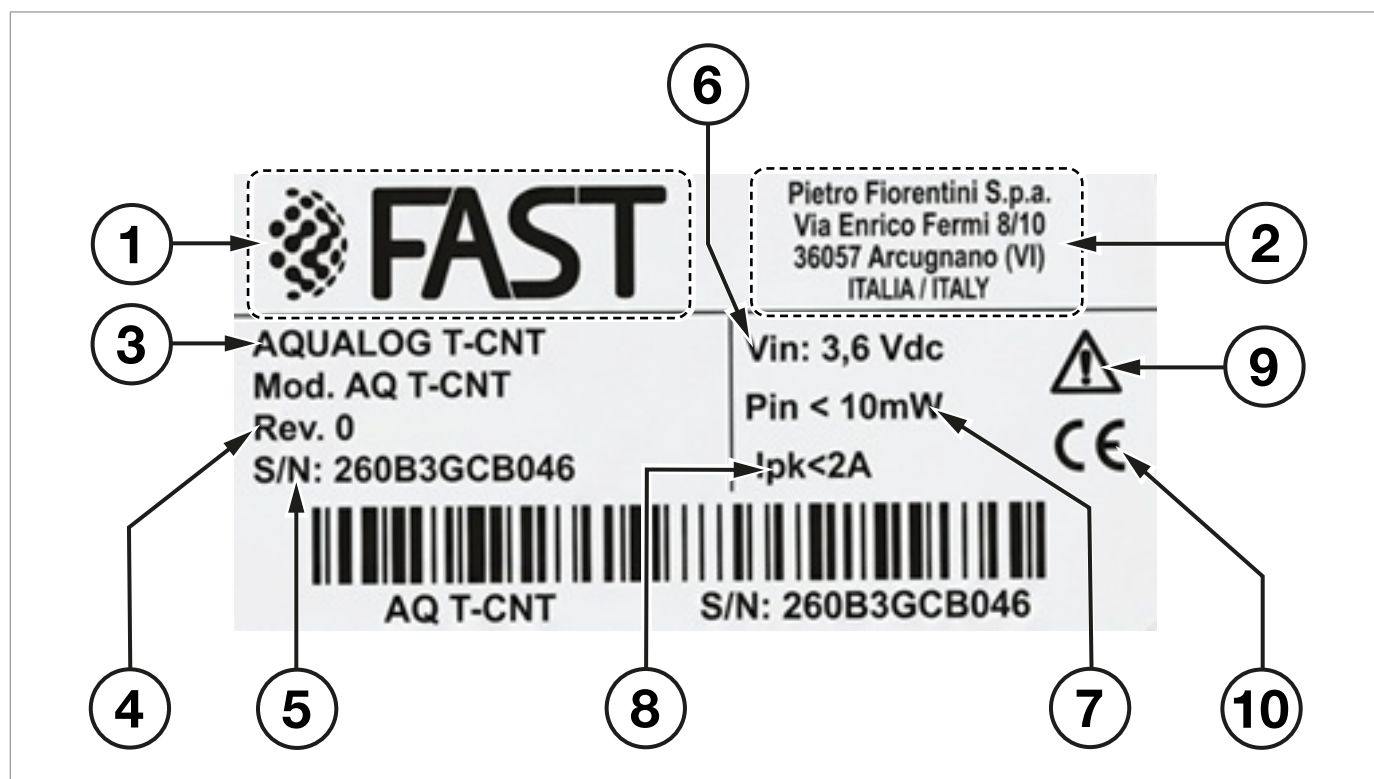

Fig. 2.1. Description of the nameplate

2.8 - GLOSSARY OF UNITS OF MEASUREMENT

Type of measurement	Unit of measurement	Description
Consumption and Volumetric flow rate	Sm ³ /h	Standard cubic metres per hour
	Sm ³	Standard cubic metres
	m ³ /h	Cubic metres per hour
	m ³	Cubic metres
	l/s	Litres per second
	l	Litres
Pressure	bar	Bar
	´wc	Water column inch
	Pa	Pascal
Temperature	°C	Degree centigrade
	°F	Fahrenheit degree
	K	Kelvin
Tightening torque	Nm	Newton metre
Sound pressure	dB	Decibel
Other measurements	V	Volt
	W	Watt
	Ω	Ohm

Tab. 2.9.

2.9 - QUALIFIED PROFESSIONAL FIGURES

Qualified operators in charge of using and managing the equipment throughout its technical service life to be used as indicated:

Professional figure	Definition
Installer	Qualified operator able to: <ul style="list-style-type: none"> • handle materials and equipment. • carry out all the operations necessary to properly install the equipment; • perform all the operations necessary to safely operate the equipment and system; • be able to perform all the operations necessary to uninstall and subsequently dispose of the equipment in compliance with the regulations in force in the country of installation.
Specialised technician/ Maintenance technician	Trained and authorised technician on the management and use of the equipment, who must: <ul style="list-style-type: none"> • be able to perform all operations required for the proper functioning of the equipment and the system, and for their safety and that of any third parties present; • perform maintenance on all parts of the equipment subject to maintenance (board and batteries); • access all device parts for visual inspection, checking equipment status, making adjustments and calibrations; • have proven experience in properly using the equipment similar to that described in this manual, and be trained, informed and instructed in this regard.
Electrical maintenance technician	Qualified technician able to: <ul style="list-style-type: none"> • perform preventive/corrective maintenance operations on all electrical parts of the device subject to maintenance or repair; • read wiring diagrams and check the correct functional cycle; • perform adjustments and operate on electrical systems for maintenance, repair and replacement of worn parts. The electrical maintenance technician can operate in the presence of voltage inside electrical panels, junction boxes, control equipment etc. only if he/she is deemed to be suitable (S.P). For general requirements, refer to the IEC EN 50110-1:2014 standard.
Person in charge of transport, handling, unloading and placing on site	Operator qualified to: <ul style="list-style-type: none"> • use lifting equipment; • the safe handling (even manual) of materials and equipment. The equipment must be lifted and handled strictly in accordance with the instructions provided by the manufacturer as well as the regulations in force at the place where the equipment is installed.

Tab. 2.10.

PAGE INTENTIONALLY LEFT BLANK

3 - SAFETY

3.1 - GENERAL SAFETY WARNINGS

WARNING!

- It is strictly forbidden to repair or make any modifications to the equipment.
- For information and warnings regarding replacing batteries, refer to chapter 9 in this manual.

ATTENTION!

Authorised operators must not carry out operations or services on their own initiative that do not fall within their competence.

Never operate the equipment:

- while under the influence of intoxicating substances such as alcohol;
- if you are using drugs that may slow reaction times.

NOTICE!

The employer must train and inform operators on how to behave during operations and on the equipment to be used.

Before installation, commissioning or maintenance, operators must:

- take note of the safety regulations applicable to the place of installation they are working in;
- obtain the necessary permits to operate when required;
- wear the personal protective equipment required by the procedures described in this instruction manual;
- ensure that the required collective protective equipment and safety information are available in the area they are operating in.

3.1.1 - SAFETY INSTRUCTIONS FOR INSTALLATION

The AQUALOG T-CNT series versions must be installed and commissioned in accordance with the applicable regulations and standards.

NOTICE!

PIETRO FIORENTINI S.p.A. shall not be liable for damage resulting from failure to comply with the instructions and from misuse.

Safety warnings

All operations on the equipment must be performed by qualified personnel.

Transformation and spare parts

Any technical changes are forbidden. Use only original spare parts intended by PIETRO FIORENTINI S.p.A.

Transport

As a rule, the equipment must be transported in an upright position and inside the original packaging box provided by PIETRO FIORENTINI S.p.A.

Upon receipt of the device, examine the supplied material.

Immediately report any shipping damage.

Storage

The equipment must be stored horizontally in a dry place at room temperature (see section 6.6.1).

WARNING!

- **Install the equipment in a compartment that meets the provisions in force on safety, away from any possible damage of mechanical origin, away from sources of heat or naked flames, in a dry place and protected from external agents.**
- **During installation, avoid mechanical stress to the inlet and outlet connections.**
- **It is strictly forbidden to repair or make any modifications to the device.**
- **The installation, removal, and any operations must be performed by qualified personnel, in compliance with the provisions in force concerning safety.**

3.2 - PERSONAL PROTECTIVE EQUIPMENT

The following table shows the Personal Protective Equipment (PPE) and its description; an obligation is associated with each symbol.

Personal protective equipment means any equipment intended to be worn by the worker in order to protect them against one or several risks that are likely to threaten their safety or health during work.

For the operators in charge, depending on the type of work requested, the most appropriate PPE from those reported in Tab. 3.11 must be used:

Symbol	Meaning
	Obligation to use safety or insulated gloves. Indicates a requirement for the personnel to use safety or insulated gloves.
	Obligation to use safety goggles. Indicates a requirement for personnel to use protective goggles for eye protection.
	Obligation to use safety shoes. Indicates a requirement for the personnel to use accident-prevention safety shoes.
	Obligation to use noise protection equipment. Indicates a requirement for the personnel to use ear muffs or ear plugs to protect their hearing.
	Obligation to wear protective clothing. Indicates a requirement for the personnel to wear specific protective clothing.
	Obligation to use a protective mask. Indicates a requirement for the personnel to use respiratory masks in the event of a chemical risk.
	Obligation to use a protective helmet. Indicates a requirement for the personnel to use protective helmets.
	Obligation to wear high visibility vests. Indicates a requirement for the personnel to use high visibility vests.

Tab. 3.11.

WARNING!

Each licensed operator is obliged to:

- **take care of his/her own health and safety and that of other people in the workplace who are affected by his/her actions or omissions, in accordance with the training, instructions and equipment provided by the employer;**
- **appropriately use the PPE made available;**
- **immediately report to the employer, the manager or the person in charge any deficiencies in the equipment and devices, as well as any dangerous conditions they may become aware of.**

3.3 - OBLIGATIONS AND PROHIBITIONS

The following is a list of obligations and prohibitions to be observed for the safety of the operator.

It is mandatory to:

- carefully read and understand the use, maintenance and warning manual;
- before installing the equipment, strictly refer to the details specified on the nameplates and in the manual;
- avoid knocks and violent impact that could damage the equipment.

It is forbidden to:

- operate in various capacities on the equipment without the PPE indicated in the work procedures described in this manual;
- operate in the presence of open flames or bring open flames close to the work area;
- smoke near the equipment or while working on it;
- use the equipment with parameters other than those indicated on the rating plate;
- use the equipment outside the operating temperature range specified in this manual;
- install or use the equipment in environments other than those specified in this manual.

3.4 - RESIDUAL RISKS

The equipment does not present residual risks for the operator related to its normal operation.





WARNING!

If there are any functional faults, do not operate.

Immediately contact PIETRO FIORENTINI S.p.A. for the necessary directions.

3.5 - SAFETY PICTOGRAMS

The equipment and/or packaging PIETRO FIORENTINI S.p.A. good bear the safety pictograms described in Tab. 3.12:

Symbol	Definition
	Symbol used to identify a GENERIC HAZARD.
	Symbol used to identify DANGERS GENERATED BY STATIC ELECTRICITY.
	Symbol applied to the packaging to identify the type of danger and risks related to the transported product, based on the classification of the European ADR agreement. Class 9 (Various dangerous substances). ADR - UN3090 (lithium metal batteries).
	The symbol indicates that the product must not be disposed of as unsorted waste but must be sent to separate collection facilities for recovery and recycling (WEEE Directive 2012/19/EU on waste electrical and electronic equipment - WEEE)

Tab. 3.12.

WARNING!

It is forbidden to remove or alter the safety pictograms on the equipment or the packaging.

3.6 - NOISE LEVEL

The AQUALOG T-CNT series has no moving parts.

For the value of the noise generated by the equipment and further information, contact PIETRO FIORENTINI S.p.A.

ATTENTION!

The obligation to use earmuffs or ear plugs to protect the hearing of qualified professional figures (reference paragraph 2.10) remains in the event that the noise in the installation environment of the equipment (depending on specific operating conditions) exceeds the value of 85 dBA.

PAGE INTENTIONALLY LEFT BLANK

4 - DESCRIPTION AND OPERATION

4.1 - GENERAL DESCRIPTION

AQUALOG T-CNT is a RTU designed to operate in harsh environments and is particularly suitable for monitoring water networks.

The device allows the monitoring of pressures, flow rates and levels in applications characterized by difficult installation conditions and the lack of mains voltage. The low power consumption allows to achieve a range of 5 years in standard service.

AQUALOG-T-CNT provides a degree of protection IP 68 to a depth of 1 meter for 7 days.

The connection to the operations center can be via GSM / GPRS or through links in Radio Frequency.

One of the main applications is the management of pressure and leak detection in networks organized in DMA. Operation is either that of Data Logger that Controller of pressure using the controls of a PRV.

In this case it is particularly useful transmission function parameters via SMS in managing advanced PCR Closed Loop (Critical Point Closed Loop) operating in conjunction with the control unit Aqualog PQ located at Critical Point Pressure DMA.

The digital outputs allow control of hydro-valves according to different modes (Day / Night, Flow Modulation, Download Pressure Regulation, Critical Point Closed Loop).

Finally AQUALOG-T-CNT has a software option that enables fast acquisition of pressure (50 Hz), allowing the investigation of pressure transients (Water Hammer).

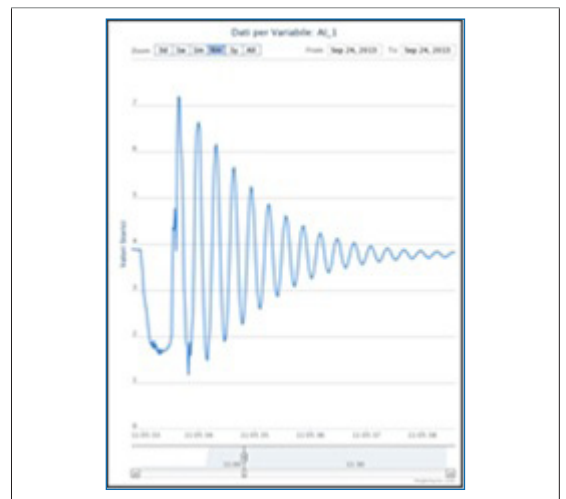

Fig. 4.2. Investigation of pressure transients (Water Hammer)

The main elements of the equipment are (see Fig. 4.3.):

Pos.	Description	Pos.	Description
1	Plastic enclosure	3	Cable glands
2	USB cable connector	4	Clamping screws

* METROLOGICAL BATTERY not visible in the picture

Tab. 4.13.

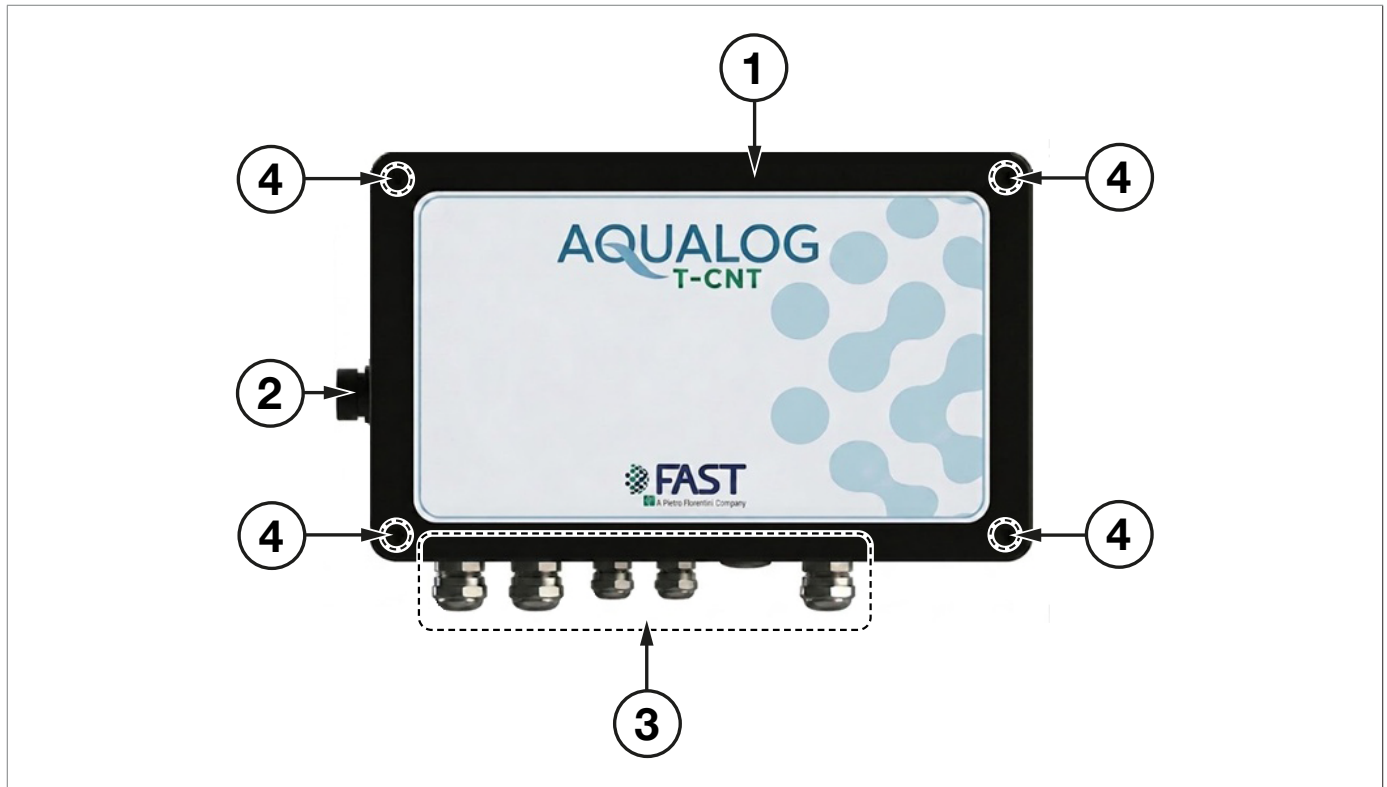

Fig. 4.3. General description AQUALOG T-CNT - Cable gland version (external view)

4.2 - POWER SUPPLY DEVICES

The AQUALOG T-CNT equipment is designed to be powered by standard 4 or 7 cells lithium thionyl chloride.

AQUALOG T-CNT can also be powered from external sources:

- photovoltaic panel
- micro-turbine
- mains power supply (230V).

NOTICE!

External power supply require kit converter from power external sources to 3,6 VDC.

4.2.1 - BATTERIES

The AQUALOG T-CNT is battery powered and has a large compartment that can accommodate even bundles of very large capacity batteries. The supply of batteries varies in accordance with the required functionality to the device by a minimum of two (2) Lithium batteries, for a total capacity of 26Ah up to 6 lithium batteries for a wide capacity up to 78 Ah. With the standard battery pack, in normal working conditions, (1 piezoresistive sensor, 1 meter, 2 data transmissions per day) autonomy than 5 years.

If there is ever a need to keep the modem on for time intervals longer or it must turn more times over 24 hours, it is necessary to use the extended battery pack that provides up to a triple capacity compared to the standard:

Features	Type	Supply
4-cell battery	Li-SOCI ₂	Standard
7-cell battery	Li-SOCI ₂	Optional

Tab. 4.14.

WARNING!

- **Only the battery models described in this manual must be used.**
- **Do not short-circuit the terminals of the battery pack.**
- **Do not attempt to open the casing.**
- **Keep away from heat sources.**
- **Do not try to recharge.**

NOTICE!

For the technical details of the battery packs and the reference operating conditions, refer to paragraph "4.4 - Technical data".

4.2.2 - CONNECTORS

4.2.2.1 - CABLE GLAND VERSION

The cable used to connect the equipment are metal and screwed directly on the box that has suitable threaded holes: each cable is also equipped with O-rings to ensure a degree of protection IP68.

The connector for the connection of the USB cable is placed on the left side of the box and is equipped with a cap to ensure the IP68 degree of protection.

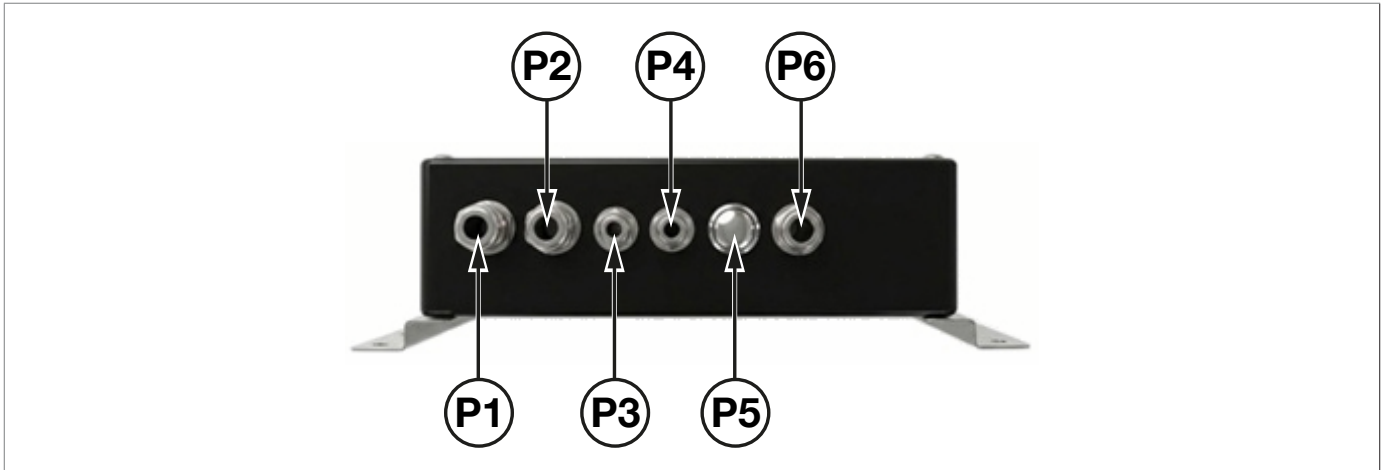

Fig. 4.4. Cable glands, lower view



Fig. 4.5. Cable glands, upper view

Cable gland	Dimensions	Description
P1	M16x1.5	Passage of the antenna or piezoresistive pressure sensor
P2	M16x1.5	Passage of the piezoresistive pressure sensor
P3	M16x1.5	Passing of the digital signals/counter meters
P4	M16x1.5	Passing of the digital signals/counter meters
P5	M16x1.5	Free / optional
P6	M16x1.5	Passage of the external antenna or piezoresistive pressure sensor
P7	M16x1.5	USB port

Tab. 4.15.

4.3 - INTENDED USE

4.3.1 - ENVISAGED USE

The equipment in question is intended for:

Operation	Permitted	Unpermitted	Work environment
Monitoring of water networks	Monitoring of water mains	Any other type of carrier other than permitted.	Application in water network installations and nodes.

Tab. 4.16.

The equipment referred to was designed to be used exclusively within the limits specified on the nameplate and according to the instructions and limits of use specified in this manual.

Safe work conditions are as follows:

- use within the limits stated on the rating plate and in this manual;
- compliance with the user manual procedures;
- routine maintenance to be carried out when and how recommended;
- special maintenance to be carried out if required;
- do not tamper with and/or bypass the safety devices.

4.3.2 - REASONABLY FORESEEABLE MISUSE

Incorrect and reasonably foreseeable misuse means the use of the equipment in a way not foreseen in the phase but which can result from result predictable human behaviour:

- using the equipment in a manner other than that referred to under “**Intended use**”.
- instinctive reaction of an operator in the event of a malfunction, accident or breakdown while using the equipment;
- behaviour resulting from carelessness;
- behaviour resulting from the use of the equipment by unauthorised and unsuitable people (children, disabled).

Any use of the equipment other than the intended use must be previously approved in writing by PIETRO FIORENTINI S.p.A. If no written approval is provided, use shall be considered **improper**.

In the event of “improper use”, PIETRO FIORENTINI S.p.A. shall not be held liable for any damage caused to people or property, and any type of warranty on the equipment shall be deemed void.

4.4 - TECHNICAL DATA

General features	
External Enclosure	Polyester
Casing protection rating	IP68 (immersion for 100 days at a depth of 1 metre)
Connectors	Cable glands with O-ring , Iron Steel AISL 304
Antennas	Internal integrated, external optional
Operating ambient temperature range	from -25°C to + 60°C
Storage temperature range	from -25°C to + 70°C
Mechanical and electrical classes	M2 E2
Power supply voltage	3.6 Vdc
Autonomy	<ul style="list-style-type: none"> • 5 years, standard equipment - 4 Lithium cells • 10 years, standard equipment - 7 Lithium cells
Power supply from external source	Trough kit DC/DC 9 - 36 Vdc (photovoltaic kit, micro-turbine) and/or 230 Vac
Memory	250,000 - 2 Megabytes, of which 1 MB data

Tab. 4.17.

Communication features	
Interface	USB mini B port
Communication protocols	<ul style="list-style-type: none"> • MODBUS • IEC 60870-5-104 • MQTT
Communication vector	<ul style="list-style-type: none"> • 1 modem GSM/GPRS/3G embedded with external antenna • 1 radio modem 169-868 MHz (optional)
Supported SIM cards	Micro SIM
Alarms/Events	Warning and management of alarms and events generated by exceeding thresholds and/or reaching physical and logical states. Using the message service for alarm notification.
Synchronisation	Daily synchronisation via SCADA server.
Data connection	Programmable centre call, configuration, missing data download, archive, date/time alignment.
Communication	Periodic, scheduled or event-driven.

Tab. 4.18.

4.5 - I/O CHANNELS

AQUALOG T-CNT is able to acquire up to 5 analog inputs and 6 digital inputs; can also drive 4 digital outputs. Refer to the section “Technical Specifications” for the limits of use.

AQUALOG T-CNT acquires the following signals*:

- 3 analogue inputs for mV/V cell piezoresistive sensors pressure or level.
- 2 analogue inputs for 4-20 mA or 0 to 10V signal (passive).
- 2 inputs for temperature acquisition from PT100/PT1000.
- 6 digital inputs that can be configured as status inputs, 2 of this can be configured as flow rate meters and other 2 can be acquired voltage signals 3.0 to 12 volts and can be used with inputs for high frequencies.
- 4 digital outputs.
- RS485 port.

* In the version with MIL-type connector, not all signals are available.



4.6 - DATA COMMUNICATION

AQUALOG T-CNT uses the following methods of communication:

- Local serial USB port.
- 2G/3G/4G modem.
- Radio Modem 169MHz or 868 Mhz (Optional).

The standard operating firmware uses the MODBUS protocol. Alternatively, other protocols may be requested. The alarms can also be sent by SMS.

4.7 - ANTENNAS

Antenna type	Image*
<p>Antenna external to the AQUALOG T-CNT bracketed device Suitable for installation in a thermowell or on stations where external elements could mask the GSM field</p>	
<p>Antenna external on the AQUALOG T-CNT device and drive-over Suitable for installation outside the thermowell with a dedicated external pocket</p>	
<p>AQUALOG T-CNT internal antenna Suitable for outdoor cabinet installations</p>	

* Images are for illustration purposes only

Tab. 4.19.

4.8 - WIRING

AQUALOG T-CNT, in its basic version, can acquire the following signals:

- 3 analogue inputs for mV/V cell piezoresistive sensors.
- 2 inputs for temperature acquisition from PT100/PT1000.
- 6 digital inputs that can be configured as status inputs, 2 of which can be configured as flow rate meters.
- 2 analogue inputs for 4-20 mA or 0 to 10V signal (passive).
- 4 digital outputs.

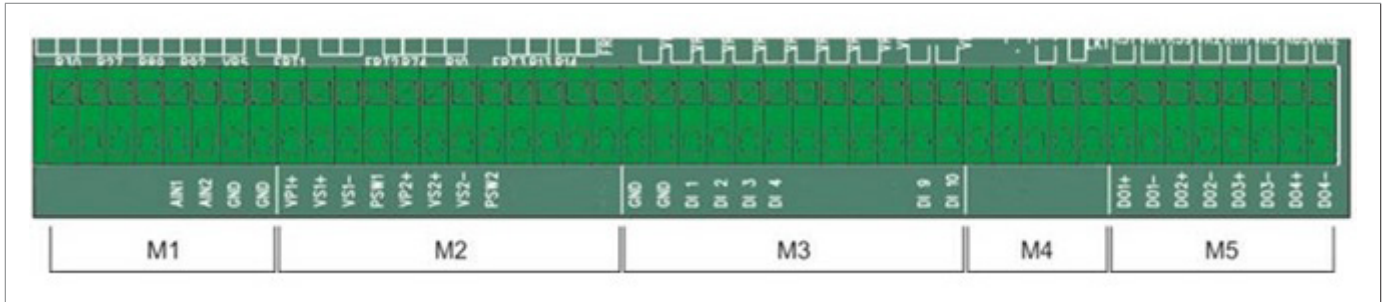
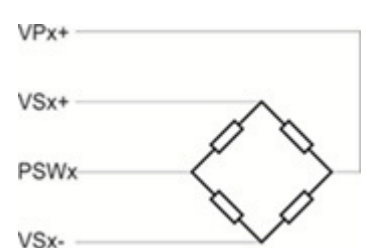

Fig. 4.6. Signals

4.8.1 - ANALOGUE PRESSURE INPUTS

Each analogue pressure input has four terminals, each with a specific function.

ANALOGUE INPUT - mV/V cell signals					
Terminal block	PIN	Terminal	Description	Connection sensor	Image
M2	9	VP1+	Positive cell power supply	IN+	
M2	10	V1S+	Positive cell signal	OUT+	
M2	11	V1S-	Negative cell signal	OUT-	
M2	12	PSW1	Negative cell power supply	IN-	
M2	13	VP2+	Positive cell power supply	IN+	
M2	14	V2S+	Positive cell signal	OUT+	
M2	15	V2S-	Negative cell signal	OUT-	
M2	16	PSW2	Negative cell power supply	IN-	
M2	17	VP3+	Positive cell power supply	IN+	
M2	18	V3S+	Positive cell signal	OUT+	
M2	19	V3S-	Negative cell signal	OUT-	
M2	20	PSW3	Negative cell power supply	IN-	

Tab. 4.20.

Fig. 4.7 shows the connection of a pressure transducer to channel 1 of the device AQUALOG T-CNT, represented as a re-sistor bridge.

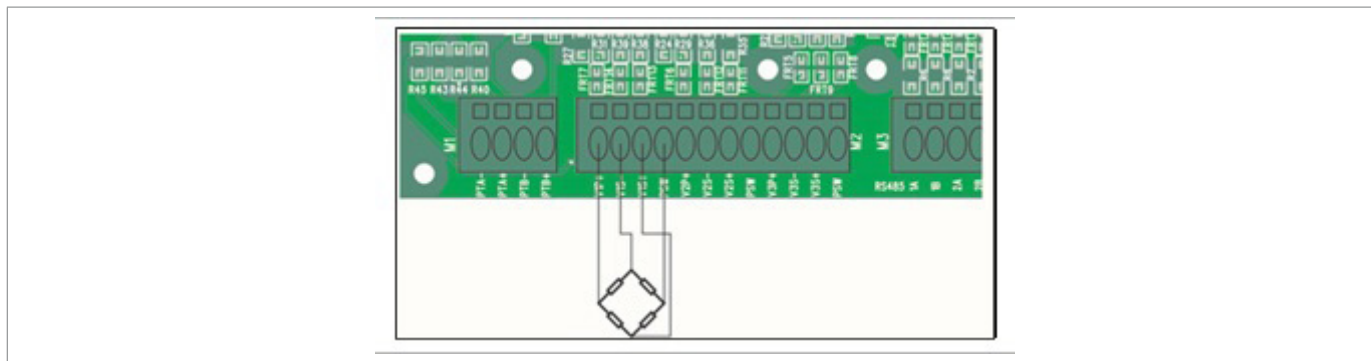

Fig. 4.7. Pressure input terminal block

4.8.2 - ANALOGUE TEMPERATURE INPUTS

Each analogue pressure input has four terminals, each with a specific function.

ANALOGUE INPUT - temperature signals PT100/PT1000 (2-wire)			
Terminal block	PIN	Terminal	Description
M1	1	PTA-	Current output from PTA
M1	2	PTA+	Current input to PTA
M1	3	PTB-	Current output from PTB
M1	4	PTB+	Current input to PTB

Tab. 4.21.

Fig. 4.8 shows the connection of a two-wire PT100/PT1000 on the first measuring channel.

A possible second resistance thermometer can be connected in a similar way on the second channel.

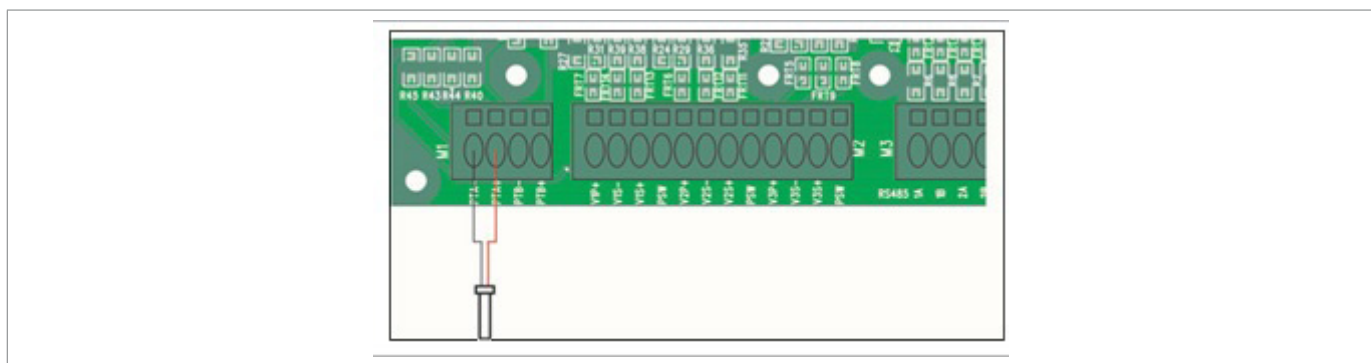

Fig. 4.8. PT100/PT1000 input terminal block

To use a four-wire connection of a resistance thermometer, the connections must be made according to Tab. 4.24:

ANALOGUE INPUT - PT1000 temperature signals (4-wire)			
Terminal block	PIN	Terminal	Description
M1	1	PTA-	Current output from PTA
M1	2	PTA+	Current input to PTA
M1	3	PTB-	Current output from PTB
M1	4	PTB+	Current input to PTB

Tab. 4.22.

All PTXX terminals are engaged for the connection of the four wires connected to the temperature-sensitive element. In this case, pay attention to the order in which the wires are connected. Compare the order with Tab. 4.22 and Fig. 4.9.

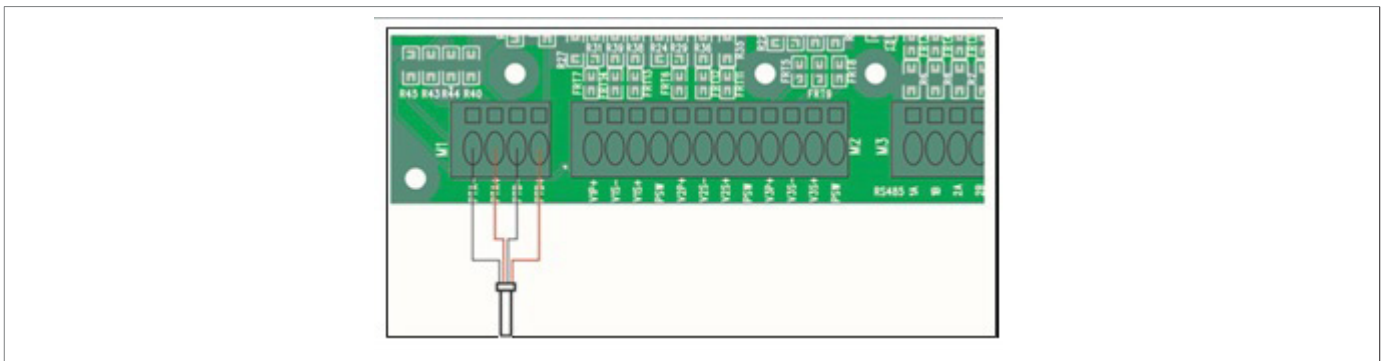



Fig. 4.9. PT1000 input terminal block (4-wire)

4.8.3 - DIGITAL INPUTS

The digital inputs must be driven via a voltage-free contact (Relay or Open Collector) which closes the input to GND. Fig. 4.10 shows the connection of a switch to the first digital input DI1.

DIGITAL INPUT - voltage-free contact (OpenCollector or Relay)				
Terminal block	PIN	Terminal	Description	Image
M3	21	GND	Mass	
M3	22	GND	Mass	
M3	23	DI1	Status/pulse input	
M3	24	DI3	Status/pulse input	
M3	25	DI3	Status/pulse input	
M3	26	DI4	Status/pulse input	

Tab. 4.23.

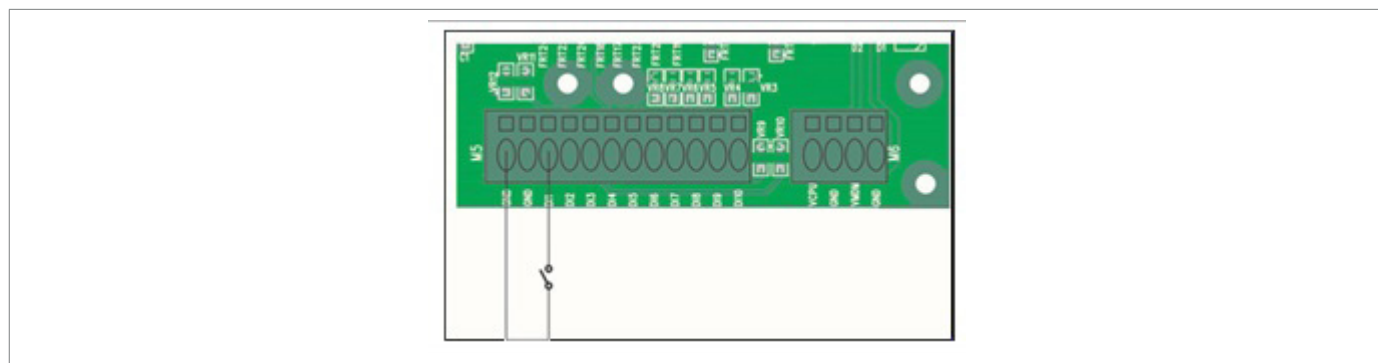
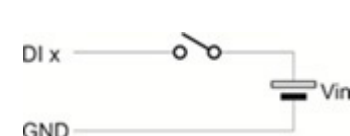

Fig. 4.10. Digital input terminal block

These digital inputs are used to acquire the status of switches present in the system and classified as single elements. Inputs DI9 and DI10, on the other hand, must be driven by a voltage that must not exceed the set maximum limit.

DIGITAL INPUT - DC voltage-drive contact				
Terminal block	PIN	Terminal	Description	Image
M3	21	GND	Mass	
M3	22	GND	Mass	
M3	31	DI9	Status/pulse input	
M3	32	DI10	Status/pulse input	

Tab. 4.24.

These inputs need to be driven by a DC voltage. A direct grounding of either of these two terminals has no effect. Fig. 4.11 shows the connection of a voltage source to digital input DI9, when the switch is:

- Closed, the digital signal is active.
- Open, the circuit returns to its idle state.

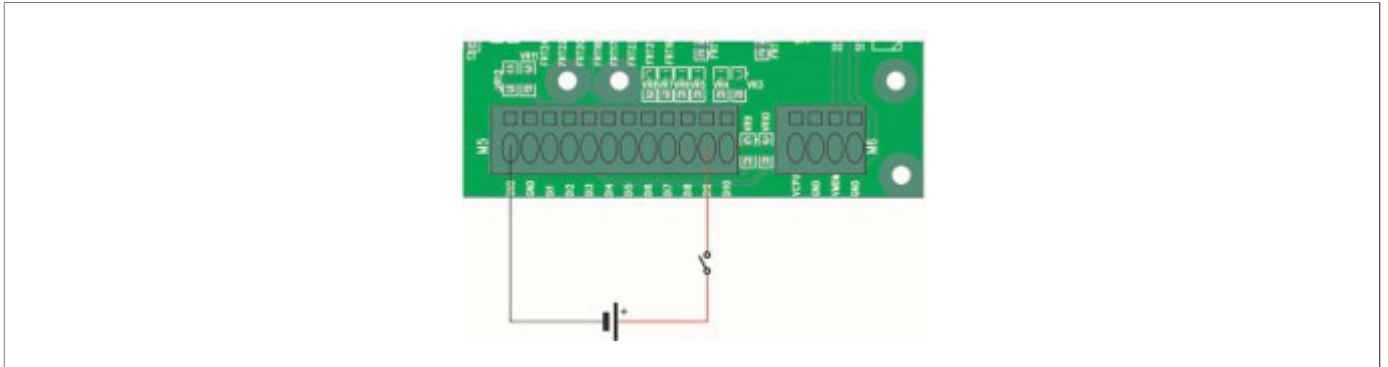

Fig. 4.11. Digital input terminal block DI9/DI10

4.9 - 4-20 MA / 0÷10V ANALOG INPUTS

! NOTICE!

Analog input is electrically passive, the sensor supply must be provided from an external source to the device.

AQUALOG T-CNT has two inputs that can be used to capture both signals such as 4 to 20 mA signal or 0 to 10.

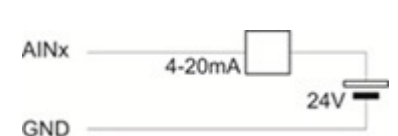
ANALOGUE INPUT - 4-20 mA signals				
Terminal block	PIN	Terminal	Description	Image
M1	5	AIN1	4-20 mA transmitter loop power supply	
M1	6	AIN2	4-20 mA / 0÷10V signal input	
M1	7	GND	4-20 mA transmitter loop power supply	
M1	8	GND	4-20 mA / 0÷10V signal input	

Tab. 4.25.

4.9.1 - DIGITAL OUTPUTS

The four digital outputs are open collector NPN: for each channel are provided in both the collector is the emitter of the transistor.

In series with the collector is a protection resistor with ohmic value 1k: this resistor limits the maximum current that the output may require equipment that is connected to its output (eg with an applied voltage of 24 volts can never be absorbed more 24 mA).

ANALOGUE INPUT - temperature signals PT100/PT1000 (2-wire)			
Terminal block	PIN	Terminal	Description
M5	38	OUT1+	Open Collector 1 Output
M5	39	OUT1-	Trasmitter 1 Output
M5	40	OUT2+	Open Collector 1 Output
M5	41	OUT2-	Trasmitter 2 Output
M5	42	OUT3+	Open Collector 1 Output
M5	43	OUT3-	Trasmitter 3 Output
M5	44	OUT4+	Open Collector 1 Output
M5	45	OUT4-	Trasmitter 4 Output

Tab. 4.26.

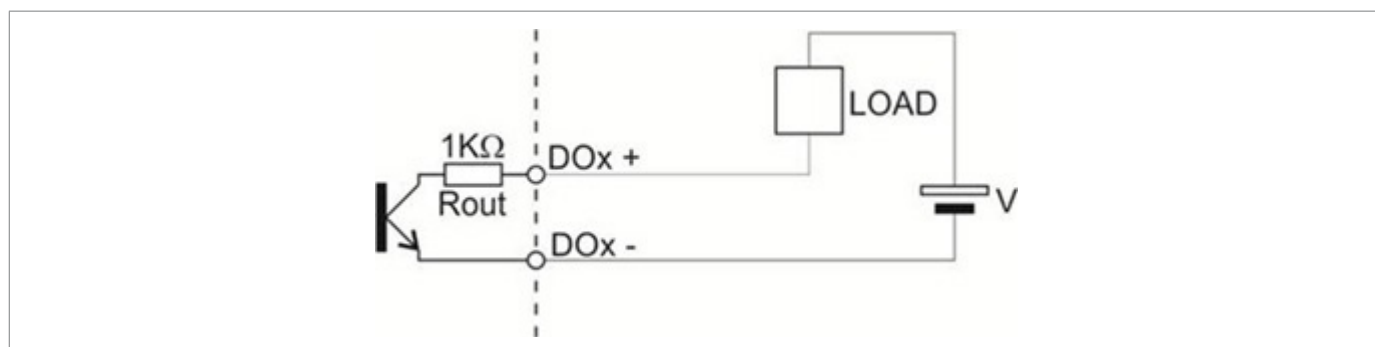

Fig. 4.12. Protection resistor

For applications where external (battery) power is not available, a dedicated alkaline battery pack must be added inside the device box AQUALOG T-CNT.

The dedicated battery pack can be either 12 VDC or 24 VDC depending on the solenoid used in the application.

Control to the solenoids requires the addition of a dedicated driver kit and wiring diagram depending on the type of application.

4.10 - ADJUSTMENT WITH SOLENOIDS' WIRING DIAGRAM

Type of solenoid used: classic.
 Drive kit: solid state relay.

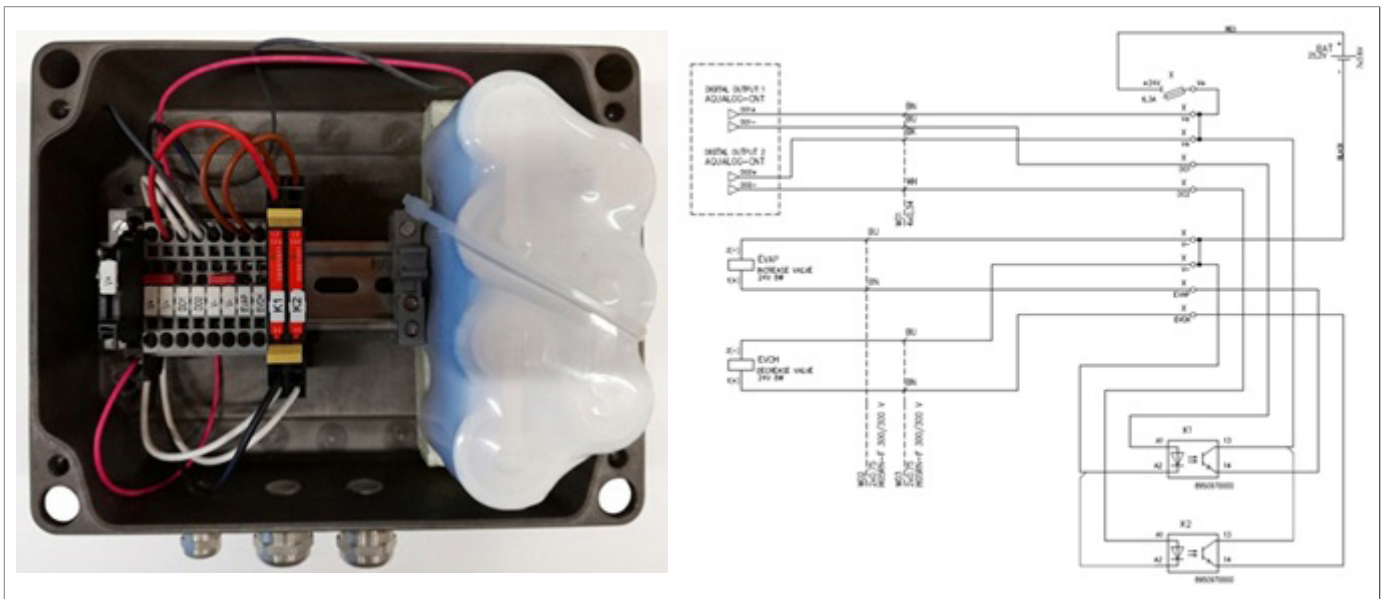

Fig. 4.13. Solid state relay, adjustment wiring diagram

4.10.1 - PRESSURE REGULATION

AQUALOG T-CNT can be configured to ensure that, using the controls of a PRV, can adjust the pressure of the District in different ways:

1. Set Point Fixed: the system acts to maintain a set point pressure
2. Set Point phase slots: the system acts to ensure the set point in the 4 blocks of days.
3. Flow Modulation: the value of pressure to be maintained depends on the scope of the application or by the user
4. Closed Loop Controller: This system receives from a device installed in Critical Point District, which oversees the value of its pressure, the 'order to raise or lower the pressure. This information is sent via SMS.

4.10.2 - MODULATION DAY / NIGHT BY A HYDRAULIC VALVE (DIGITAL OUTPUTS)

The Day / Night function implements a clock actuator for controlling a hydraulic valve via two digital outputs. The output 1 is activated in the time interval defined during the day while the output 2 is activated during the night. Setting hours Day / Night can be made from the RTU menu item CONFIGURATION ALARMS.

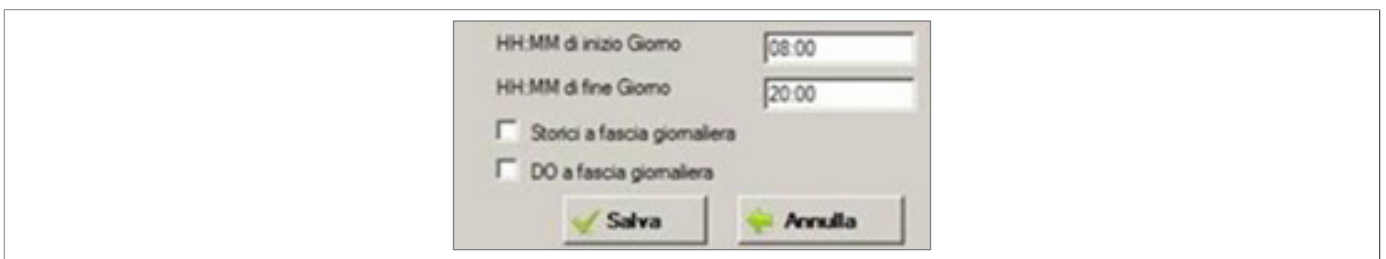

Fig. 4.14. Configuration of start times and end day

5 - USER INTERFACE

5.1 - LOCAL COMMUNICATION INTERFACE

The main local communication interfaces are:

- USB (on demand).

5.1.1 - COMMUNICATION INTERFACE VIA WI-FI

The USB interface is located inside the RTU (optional external) and allows a fast data exchange with the PC.

The USB connection procedure may require the installation of communication drivers from STMicroelectronics, which are available free of charge on the website.

Connection requires:

- USB A/USB B Mini cable, length approx. 150mm (cod. ICOC MUSB-AA-030).



Fig. 5.15. Interface for USB connection

To connect via USB to the machine, proceed as follows:

Step	Action
1	Remove the RTU cover closure screws.
2	Open the control panel from PC.
3	Select the “Device Management” item.
4	Search for the “STMicroelectronics Virtual COM Port”.
5	Run the Rainbow programme from the PC.
6	Select the desired RTU and double-click the mouse.
7	Select “RTU” in the top left-hand corner.
8	Select “Monitor Diagnostics” from the drop-down menu.
9	Enter the COM port under ‘Serial Port’ paired with the USB connection.
10	Click the “Connect” button.
11	Wait for connection and interact with the RTU

Tab. 5.27.

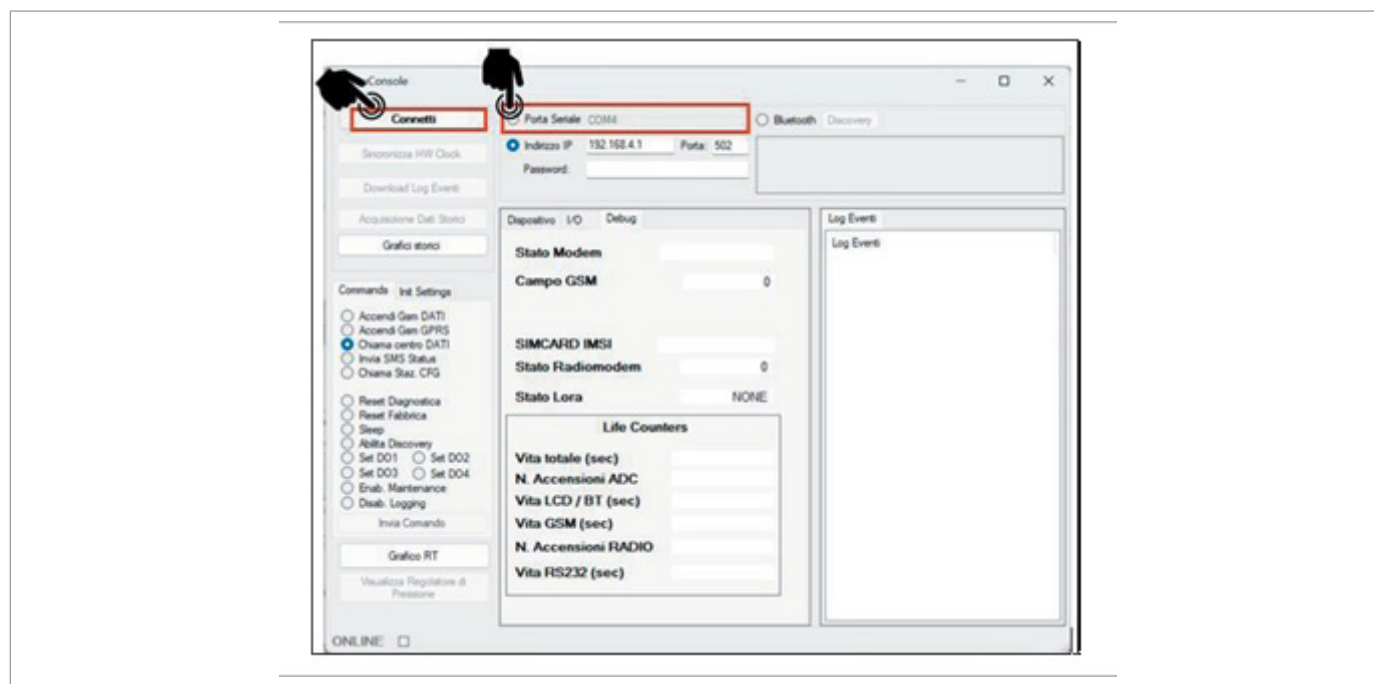

Fig. 5.16. COM port connection

6 - TRANSPORT AND HANDLING

6.1 - SPECIFIC WARNINGS FOR TRANSPORT AND HANDLING

NOTICE!

Transport and handling must be carried out in compliance with the regulations in force in the country of installation by personnel who are:

- qualified (specially trained);
- who are familiar with accident prevention and workplace safety regulations;
- authorised to use lifting equipment.

Transport and handling

Operator qualification	<ul style="list-style-type: none"> • Installer.
PPE required	 <p>WARNING!</p> <p>The PPE listed in this table is related to the risk associated with the equipment. For the PPE required to protect against risks associated with the workplace, installation or operating conditions, please refer to:</p> <ul style="list-style-type: none"> • the regulations in force in the country of installation; • <u>any information provided by the Safety Manager at the installation facility.</u>
Weights and dimensions of the equipment	For dimensions and weights please refer to “6.3 - Physical characteristics of the device”.

Tab. 6.28.

6.1.1 - PACKAGING AND FASTENERS USED FOR TRANSPORT

The transport packaging is designed and manufactured to avoid damage during normal transport, storage and handling. The equipment must be kept in the packaging until installation.

Upon receiving the equipment, please:

- make sure that no part has been damaged during transport and/or handling;
- immediately report any damage found to PIETRO FIORENTINI S.p.A..

NOTICE!

PIETRO FIORENTINI S.p.A. shall not be liable for any damage to people or property caused by accidents due to failure to comply with the instructions provided in this manual.

Tab. 6.25 describes the types of packaging used:

Ref.	Type of packaging	Image
A	Single box	

Tab. 6.29.

6.2 - PACKAGING CONTENT

AQUALOG T-CNT is shipped with:

- battery inside, to be connected;
- internal antenna;
- expansion board (on request);
- wall-mounting bracket (on request).

6.3 - PHYSICAL CHARACTERISTICS OF THE DEVICE

6.3.1 - CABLE GLAND VERSION

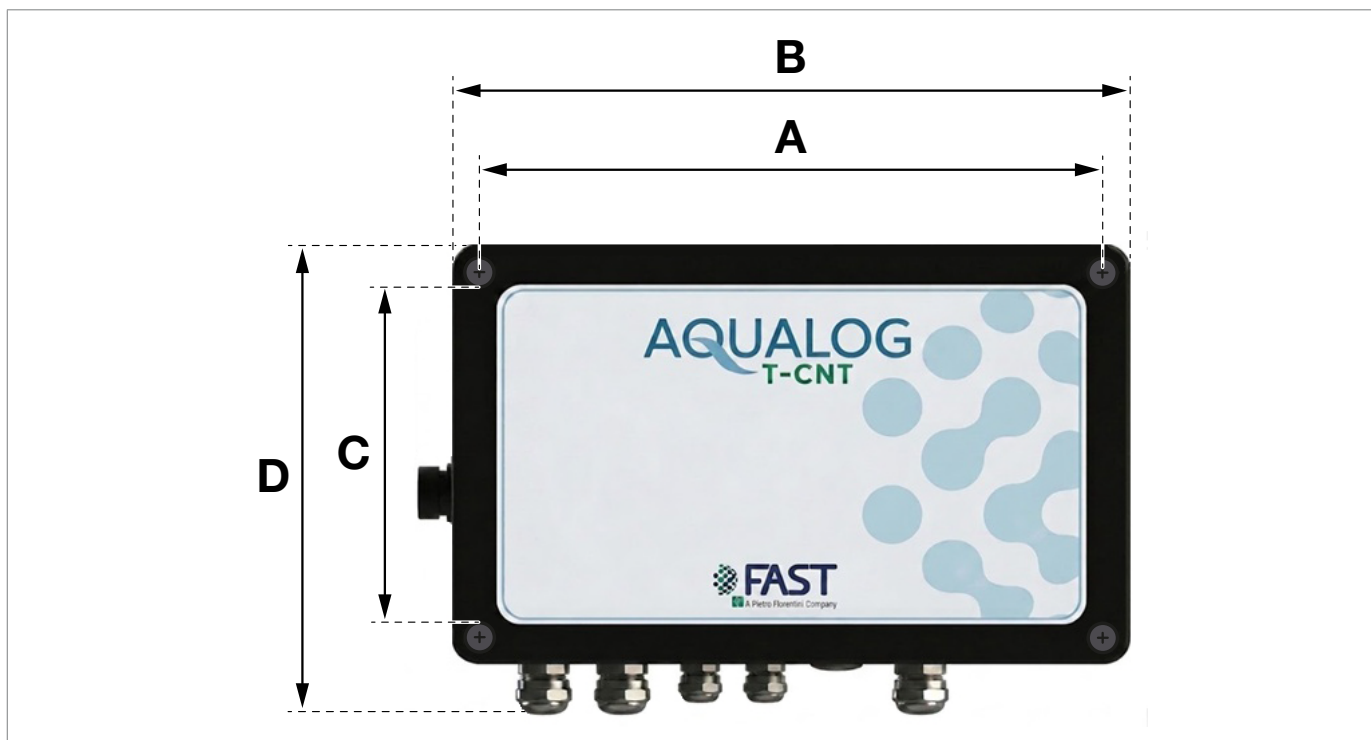

Fig. 6.17. Dimensions AQUALOG T-CNT, cable version, front view

Weights and dimensions	
A	260 mm
B	272 mm
C	160 mm
D	180 mm
Weight	2 kg

Tab. 6.30.

6.4 - EQUIPMENT ANCHORING AND LIFTING METHOD

HAZARD!

Using lifting equipment (if necessary) for unloading, carrying and handling packages is reserved only for skilled operators who have been properly trained (and are appropriately qualified if required by the regulations in force in the country of installation) and are familiar with:

- accident prevention rules;
- workplace safety provisions;
- lifting equipment features and limits.

HAZARD!

Before handling a load, make sure that its weight does not exceed the load capacity of the lifting equipment (and any other lifting tools) specified on the specific plate.

ATTENTION!

Before moving the equipment:

- remove any movable or hanging component or firmly secure it to the load;
- protect fragile equipment;
- check that the load is stable;
- make sure to have perfect visibility along the route.

6.4.1 - FORKLIFT HANDLING METHOD

HAZARD!

It is forbidden to:

- do not transit under suspended loads;
- do not move the load over the personnel operating in the site/plant area.

WARNING!

The following is not allowed on forklifts:

- carrying passengers;
- lifting people.

WARNING!

During all handling operations, pay close attention to avoid impact or vibrations of the equipment batteries.

If cardboard boxes (single or multiple) are carried on a pallet, proceed as indicated in Tab. 6.31:

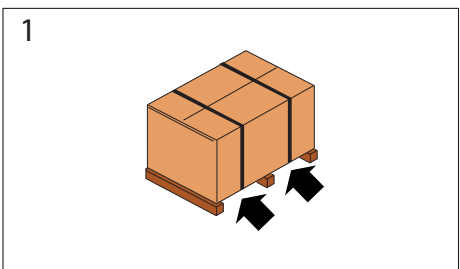
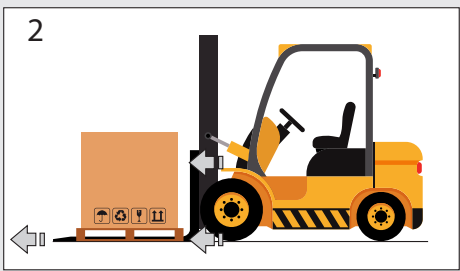
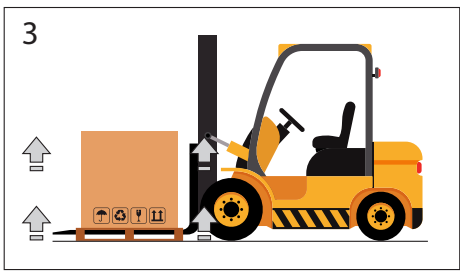
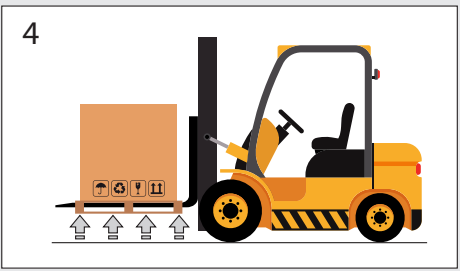
Step	Action	Image
1	Place the forks of the forklift under the load surface.	
2	Make sure that the forks protrude from the front of the load (by at least 5 cm), far enough to eliminate any risk of the transported load tipping.	
3	Raise the forks until they are touching the load. NOTICE! Fasten the load to the forks with clamps or similar devices if required.	
4	Slowly lift the load by a few dozen centimetres and check its stability, making sure that the centre of gravity of the load is at the centre of the lifting forks.	

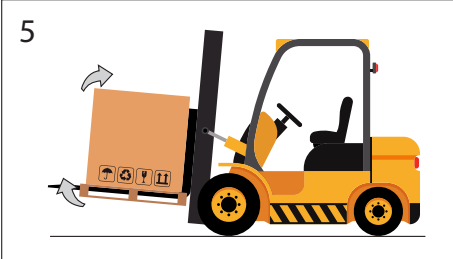
Step	Action	Image
5	Tilt the mast backwards (towards the driver's seat) to help the over-turning moment and to ensure greater load stability during transport.	
6	Adjust transport speed according to the type of floor and load, avoiding sudden manoeuvres. ⚠ WARNING! In case of: <ul style="list-style-type: none"> • obstacles along the path; • particular operating situations; hinder operator visibility, the assistance of a ground operator is required, standing outside the range of action of the lifting equipment, with the task of signalling.	-
7	Place the load in the chosen installation area.	-

Tab. 6.31.

6.5 - PACKAGING REMOVAL

Packaging removal	
Operator qualification	<ul style="list-style-type: none"> Installer.
PPE required	<div style="display: flex; align-items: center;">  </div> <div style="background-color: #f4a460; padding: 5px; margin-top: 10px;"> <p>⚠ WARNING!</p> </div> <p>The PPE listed in this table is related to the risk associated with the equipment. For the PPE necessary to protect against risks associated with the workplace or operating conditions, please refer to:</p> <ul style="list-style-type: none"> the regulations in force in the country of installation; <u>any information provided by the Safety Manager at the installation facility.</u>

Tab. 6.32.

To unpack the cardboard boxes (single or multiple) supported by a pallet, proceed as described in Tab. 6.33:

Step	Action
1	Remove the stretch film around the pallet.
2	Remove the 4 support corners.
3	<p>Move the boxes of the equipment from the pallet to their intended place.</p> <div style="border: 1px solid #0070c0; padding: 5px; margin-top: 10px;"> <p>⚠ NOTICE!</p> <p>Have at least 2 operators manually move the packages if required due to their dimensions/weight.</p> </div>

Tab. 6.33.

⚠ NOTICE!

After removing all packaging materials, check for any anomalies.
If there are anomalies:

- do not install the equipment;
- contact PIETRO FIORENTINI S.p.A. and specify the details provided on the equipment rating plate.

⚠ WARNING!

The single piece of equipment is contained in a specifically created cardboard box.
Avoid taking the equipment out of the box before its installation.

6.5.1 - PACKAGING DISPOSAL

⚠ NOTICE!

Sort the various materials making up the packaging and dispose of them in compliance with the regulations in force in the country of installation.

6.6 - STORAGE AND ENVIRONMENTAL CONDITIONS

WARNING!

Protect the equipment from blows and impacts, even accidental, until it is installed.

NOTICE!

The meters must be stored in an upright position.

If the equipment needs to be stored for an extended period, the minimum environmental conditions for the intended storage are provided in Tab. 6.34. Compliance with these conditions will guarantee the declared performance:

Conditions	Data
Maximum storage period	A maximum storage period is not defined as it is only limited by the life span of the product.
Storage temperature	from -25°C to +60°C
Relative humidity	95%

Tab. 6.34.

6.6.1 - STORAGE OF THE SPARE BATTERIES

Any spare battery packs ordered must be stored:

- in their original packaging or alternatively in ADR compliant packaging, by placing the containers at ground level (do not stack above 1.2 m);
- in a place with a temperature $\leq 25^{\circ}\text{C}$ in order to preserve its electrical characteristics;
- away from flammable material, water and rain, corrosive agents, heat sources;
- in the absence of direct sunlight;
- away from metal objects;
- so as to prevent any accidental movement;
- so as to prevent their terminals from bearing the weight of other elements stacked on them.

Battery packs must not be stored:

- with damaged batteries;
- with exhausted batteries.

NOTICE!

The packages must be labelled in accordance with ADR, i.e. with a diamond shape on the side and code UN3090.



7 - INSTALLATION

7.1 - GENERAL WARNINGS

 **WARNING!**

The installation must be performed by qualified personnel, in compliance with the provisions in force concerning safety.

 **WARNING!**

For the safe use of the equipment, respect the permitted environmental conditions and comply with the data shown on the nameplate.

 **WARNING!**

It is forbidden to make modifications to the equipment.

 **WARNING!**

PIETRO FIORENTINI S.p.A. is not liable for damage caused by incorrect installation of the equipment and/or otherwise different from that indicated in this manual.

7.2 - INSTALLATION PRE-REQUISITES

7.2.1 - ALLOWED ENVIRONMENTAL CONDITIONS

 **NOTICE!**

For details on the allowed environmental conditions (temperature range and classification) refer to paragraph “4.4 - Technical data”.

 **WARNING!**

PIETRO FIORENTINI S.p.A. is not liable for damage and/or malfunctions caused by installation in environments other than those permitted.





7.3 - CHECKS BEFORE INSTALLATION

The installation site must be suitable for the safe use of the equipment.

The equipment installation area must have lighting that guarantees the operator good visibility during the installation phases.

Before installation, it must be ensured that:

- the installation compartment meets current safety requirements
- there are no impediments that could hinder the installer's installation operations;
- the equipment connections are clean and undamaged.

Installation	
Operator qualification	<ul style="list-style-type: none"> • Installer.
PPE required	<div style="display: flex; align-items: center;">      </div> <div style="background-color: #f4a460; padding: 5px; margin-top: 5px;"> ⚠ WARNING! </div> <p>The PPE listed in this table is related to the risk associated with the equipment. For the PPE required to protect against risks associated with the workplace, installation or operating conditions, please refer to:</p> <ul style="list-style-type: none"> • the regulations in force in the country of installation; • <u>any information provided by the Safety Manager at the installation facility.</u>
Equipment required	Keys to fix inlet and outlet connections fittings/equipment.

Tab. 7.35.

7.4 - INSTALLATION PROCEDURE

The cables supplied with the pressure sensors have a mechanically non-compact internal structure due to the presence of the compensation tube and any shielding.

This structure causes deformations to the cable and changes the circular shape when tightening the cable gland. This phenomenon weakens the tightness in long-term immersions.

For the connection of sensors and/or external equipment via digital exchange signals, use cables suitable for the installation site, with a compact internal structure.

Neoprene cables are preferred over others due to their compactness and elasticity. They ensure that tightness is maintained in the coupling with the cable gland even as it ages.

NOTICE!

Prevent weakening of the cables, or when using PVC cables or cables with compact internal structures:

- **use a tube of medium-gauge heat shrink tubing to the cable.**
- **apply an adhesive such as RayTech MTR 10/3 to coat the cable in the section inside the cable gland. The adhesive stiffens the structure.**

7.4.1 - EQUIPMENT ASSEMBLY AND SIM INSERTION

To ensure that the system is sealed against the penetration of liquids in the event of temporary immersion, take care to insert the cables correctly into the box.

Only connect sensors to the equipment with the same degree of immersion resistance.

Any junction boxes or equipment connected to the controller by cables must guarantee the same degree of immersion tightness.

Step	Action
1	Secure the device AQUALOG T-CNT with the brackets.
2	Unscrew and remove the cover screws.
3	Remove the cover.
4	Disconnect the battery pack.
5	<p>Connect the signal cables from the field (refer to section '4.8 - Wiring').</p> <div data-bbox="223 1344 1476 1534" style="border: 1px solid black; padding: 5px;"> <p> NOTICE!</p> <p>The terminals used for connection are 'spring-loaded'. To perform this step:</p> <ul style="list-style-type: none"> a. Fully press the unlock button with the relative tool. b. Insert the wire into the terminal. c. Release the unlock button. </div>
6	Tighten the cable glands.
7	If you have an external antenna, connect the antenna to the appropriate connector on the external tail.

To insert the SIM card:

Step	Action
8	<p>Insert the SIM into the modem slot (Fig. 7.18).</p> <div style="border: 1px solid black; padding: 5px;"> <p>! NOTICE!</p> <ul style="list-style-type: none"> • 8.1 In case of difficulty, disconnect the modem from the motherboard and insert the SIM card into the designated slot (Fig. 7.18). • 8.2 Carefully reinsert the modem, ensuring correct alignment between the modem pins and the connector on the motherboard. </div>
9	Connect the battery pack.
10	Connect via USB or Wireless interface.
11	Configure the equipment (refer to chapter “8 - Configuration”).
12	Check with the Rainbow instruments or on the display that the measurements are correct.
13	Make a connection test and check that communication is stable (see “8.10 - 2G, 3G, 4G Data call communication test” and “8.12 - Reset”).
14	Place the cover on the box.
15	<p>Insert all the screws first, then tighten them.</p> <div style="background-color: #f4a460; padding: 5px;"> <p>! WARNING!</p> <p>Ensure that the cover is properly positioned and fully seated. Verify that no cables are protruding. Tighten the screws to maintain the IP68 protection rating.</p> </div>

Tab. 7.36.

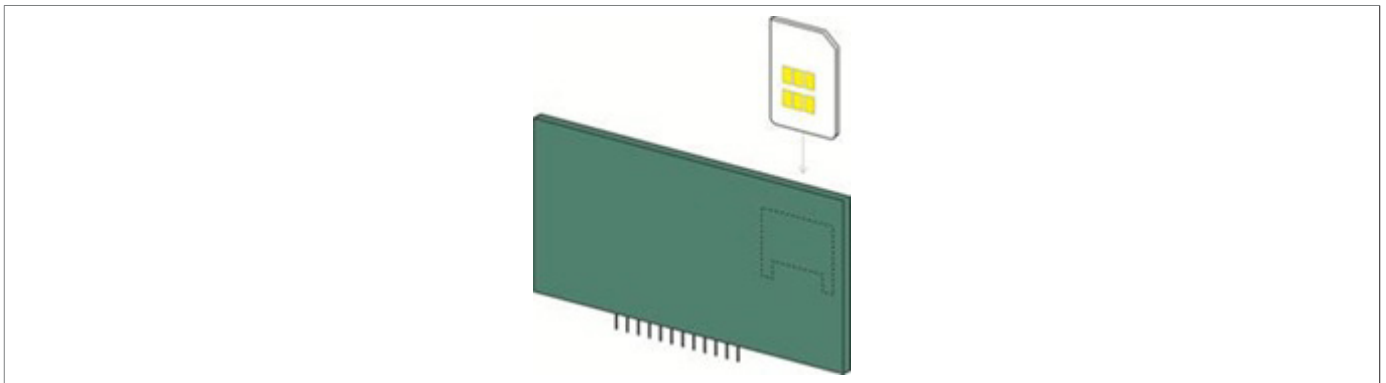

Fig. 7.18. Installation procedure

7.5 - MOUNTING AND CABLING

7.5.1 - MOUNTING

The equipment can be mounted either on the wall either using the bracket that can be supplied.

In the first case the installation is performed via four anchors whose screws are housed in the four holes provided on the box: these holes are made on the outside of the area protected by the seal, and then, while being closed by the main cover do not affect the degree of protection of the container.

The four holes are arranged at the vertices of a rectangle whose dimensions are 240 x 110 mm.

In the second case, the container is connected in a manner integral with the mounting bracket by means of four screws with nut.

7.5.2 - CONNECTING CABLES I/O

The signals for interfacing with the field all flock to the terminal blocks on the bottom side of the board, as shown in Fig.7.19. Terminals are all side by side but grouped in “terminal” that group together homogeneous signals.

The connections to the field sensors are described in detail in Chapter 4.

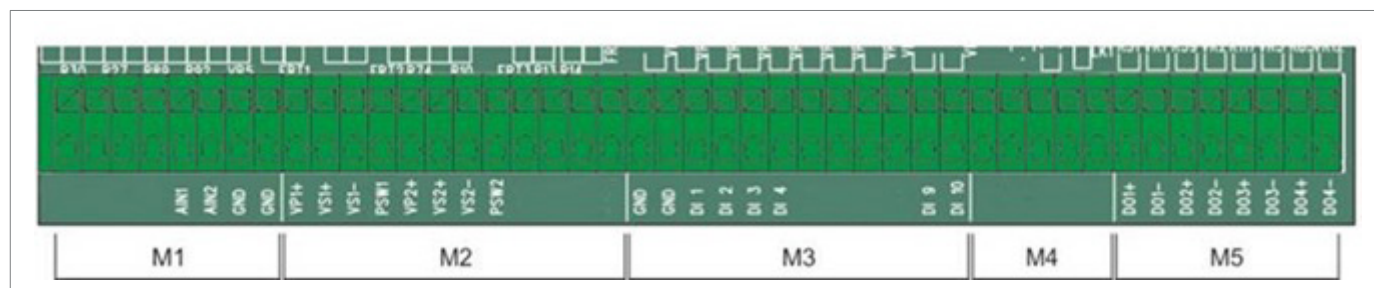

Fig. 7.19. Terminal blocks of the board

The terminals used for the connections are spring-type for which to attach a conductor, simply press the release button completely, insert the wire into the terminal, and then release the reset button.

a.1.2 Cable glands (P1 to P6)

In the standard configuration the device is equipped with 5 cable glands and a threaded hole closed by a cap with O-ring: for special needs, you can replace the cap with a cable gland.

All cable glands, the plug and the USB connector on the left side of the box provide a degree of protection equivalent to IP68. When the USB connector is not used, you must close it with the cap that guarantees a level of protection equivalent to IP68.

a.1.1.6 P1

P1 is the cable used to connect the pressure transducer piezoelectric terminals VP1 +, VS1 +, VS1- and PSW1. Where there is the need to connect the shield of the cable connection, this can be settled at one of the terminals GND (7.8).

Alternatively it can be used for the connection of a sensor 4 to 20 mA / 0 to 10 V to be connected between terminals AIN1 and GND in the manner illustrated in Chapter 4.

This gland is suitable for cable diameters from 5 to 10mm (if needed may be mounted a model for diameters from 4 to 8mm).

a.1.2.6 P2

The gland P2 is used for the connection of piezoelectric pressure transducer to terminals + VP2, VS2 +, and VS2- PSW2. Where there is the need to connect the shield of the cable connection, this can be settled at one of the terminals GND (7.8).

Alternatively it can be used for the connection of a sensor 4 to 20 mA / 0 to 10 V to be connected between terminals AIN2 and GND in the manner illustrated in Chapter 4.

This gland is suitable for cable diameters from 5 to 10mm (if needed may be mounted a model for diameters from 4 to 8mm).

a.1.3.6 P3

The cable gland P3 is used for the connection to Digital signals (DI 1- OF 10) input between which also the emitter of any pulses from Flow Meter: the connections are shown in Chapter 4.

All inputs accept signals from voltage free contacts while OF THE 9 and 10 also accept voltage signals.

This gland is suitable for cable diameters from 3 to 6.5mm (if needed may be mounted a model for diameters from 2 to 5mm).

a.1.4.6 P4

The gland P4 is used for the cable connection of the digital outputs: there are four digital outputs Open Collector each using two conductors, for a complete connection are then needed eight conductors. There are no points in common between the outputs, and then each pair of conductors must be connected to terminals counterparts, DOx +, DOx-, where x varies from 1 to 4.

This gland is suitable for cable diameters from 3 to 6.5mm (if needed may be mounted a model for diameters from 2 to 5mm).

a.1.5.6 P5

In position P5 is not normally present the cable but a cap that hermetically closes the threaded hole: for particular applications can require the installation of an additional cable gland and therefore have a new input line to the box.

The thread provided is M16x1,5mm thymus glands and can stay for cable diameter 5 / 10mm. or 4 / 8mm.

a.1.6.6 P6

The gland P6 is used to dump the cable which must be connected the antenna of GSM / GPRS module. The cable that comes out of this gland is internally connected to the SMA connector installed on the bracket that defines the area of the batteries, and provides outside an SMA connector which connect the antenna itself.

a.2.2 Requirements for maintaining grade IP

In order to ensure the tightness of the system to the penetration of liquid in case of temporary immersion draw particular attention during the installation of the electrical connections.

In addition to making the correct insertion of cables in the box must be taken all the necessary measures to prevent liquids from penetrating into the cassette through the interstices of the cables.

They will then be connected to the equipment only sensors that are able to seal the immersion and possible junction boxes or equipment connected to the controller via cables must guarantee the same degree of tightness for immersion.

Special warnings for pressure sensors

Very often the cables supplied with the pressure sensors have an internal structure mechanically non-compact due to the presence of the sheath compensation and any shielding, this type of structure means that the cable is subjected to deformations that alter the circular shape during the tightening the cable entry, this phenomenon can weaken the seal tightening diving long term.

To prevent this, we recommend applying to cable a tube of heat shrink tubing medium thickness with glue type RayTech MTR 10/3 who plays the lead in the stretch inserted into the gland enforcing in this way the structure (Fig.7.20).

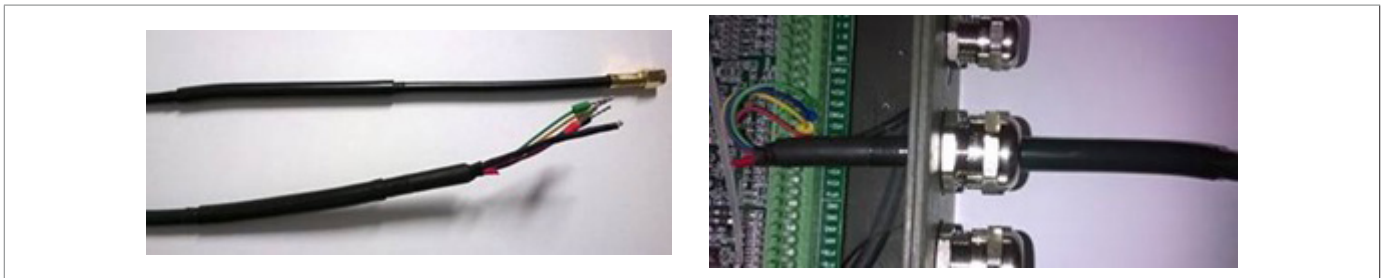

Fig. 7.20. Recommended application method (pressure sensors)

Special notes for the connection of the GSM / GPRS

The connection of the antenna data transmission takes place via a cable headed with SMA connectors already installed on Aqualog-T-CNT.

In case of replacement of the tail is recommended the application of a tube of heat shrink tubing medium thickness with glue type RayTech MTR 10/3 who plays the lead in the stretch inserted into the gland (Fig.7.21).

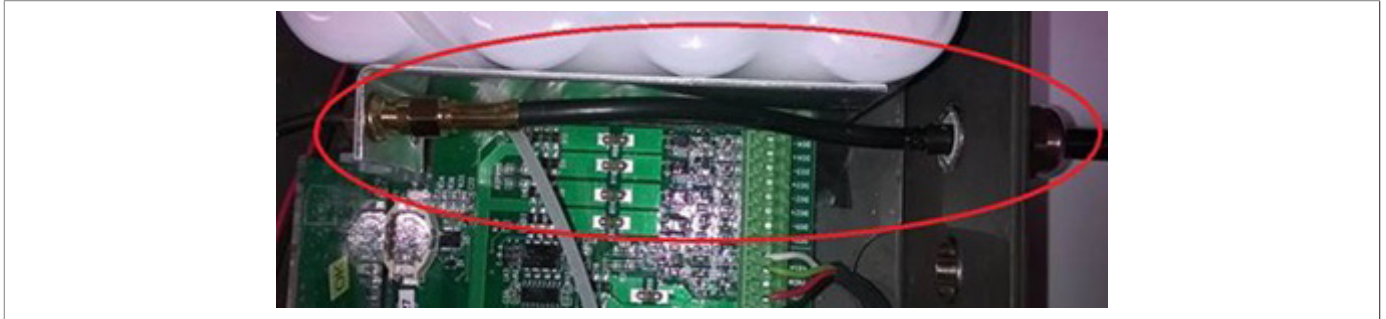

Fig. 7.21. Recommended application method (connection of the GSM / GPRS)

Particular attention should be paid in the realization of the connection to the connector SMA wheel.

The antenna must be installed in order to prevent infiltration of water at the ends of the cable or be suitable for immersion. The coupling of the connectors must be protected from water inlet by the application of self-agglomerating tape (Fig.7.22).



Fig. 7.22. Recommended application method (protection against water infiltration)

The self-amalgamating tape should be applied according to the rules of the manufacturer, please note that normally there is a further protection by wrapping PVC tape.

Special warnings for connecting signals Input / output

For the connection of sensors and / or external equipment through exchange digital signals (cable P4 and P5) we recommend the use of cables suitable to the installation site and which have an internal structure compact, cables Neoprene are better than others for their firmness and elasticity that ensure the maintenance of the estate during the work inside the gland also aging.

In the case of use of PVC cables or internal structures not compact it is recommended the application of a tube of heat shrink tubing medium thickness with glue type RayTech MTR 10/3 who plays the lead in the stretch inserted into the gland.

PAGE INTENTIONALLY LEFT BLANK

8 - CONFIGURATION

8.1 - SAFETY REQUIREMENTS FOR CONFIGURATION

Configuration	
Operator qualification	<ul style="list-style-type: none"> Specialised technician. Installer.
PPE required	<div style="display: flex; align-items: center;">  </div> <div style="background-color: #f4a460; padding: 5px; margin-top: 5px;"> <p>⚠ WARNING!</p> </div> <p>The PPE listed in this table is related to the risk associated with the equipment. For the PPE required to protect against risks associated with the workplace, installation or operating conditions, please refer to:</p> <ul style="list-style-type: none"> the regulations in force in the country of installation; <u>any information provided by the Safety Manager at the installation facility.</u>

Tab. 8.37.

8.2 - EQUIPMENT CONFIGURATION

NOTICE!

Equipment configuration must be carried out by authorised and qualified personnel.

Configuration of the AQUALOG T-CNT dataloggers can be done via the **Rainbow software**. Please refer to the software manual for detailed operating instructions.

The tool's main features and advanced firmware functionality will be described below.

8.2.1 - STARTING THE RAINBOW SOFTWARE

To start the software:

Step	Action
1	Launch the Rainbow programme.
2	Select the desired language (Fig. 8.23).
3	Select the desired RTU (Fig. 8.24).

Tab. 8.38.

NOTICE!

If the desired RTU is not present, follow the procedure outlined in section 8.2.2.

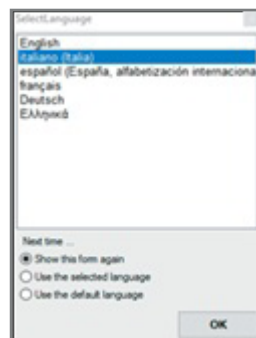

Fig. 8.23. Language selection

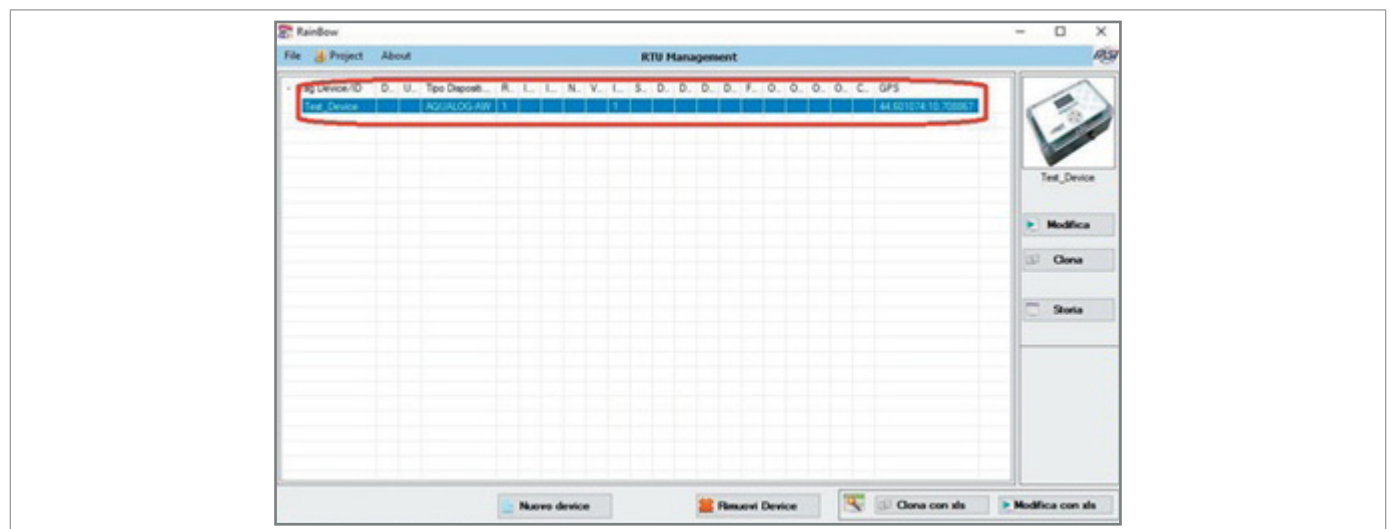

Fig. 8.24. RTU selection

8.2.2 - OPENING THE DATABASE

The list of RTUs is paired with a database saved in a file with the extension **.sdf**.

If it is necessary to select an RTU from another list, you must:

1. Select '**File**' at the top left, then '**Open Database**' and left-click.

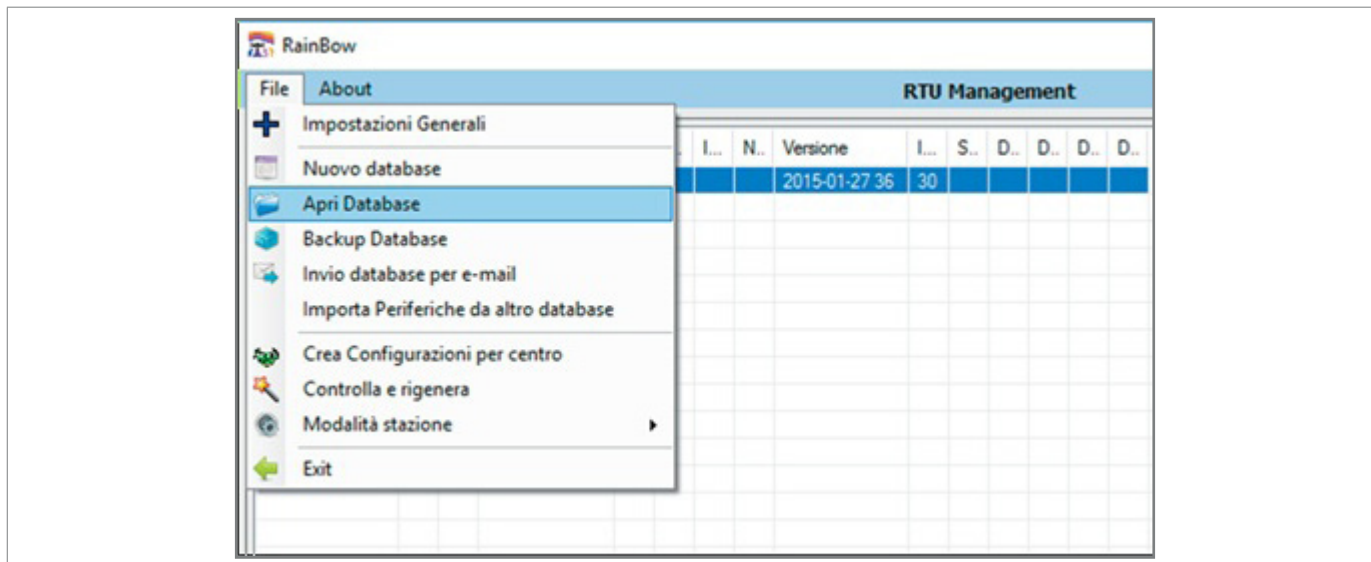

Fig. 8.25. Opening the database

2. Search the PC's network drive for the file with the extension **.sdf**, click on '**Open**'

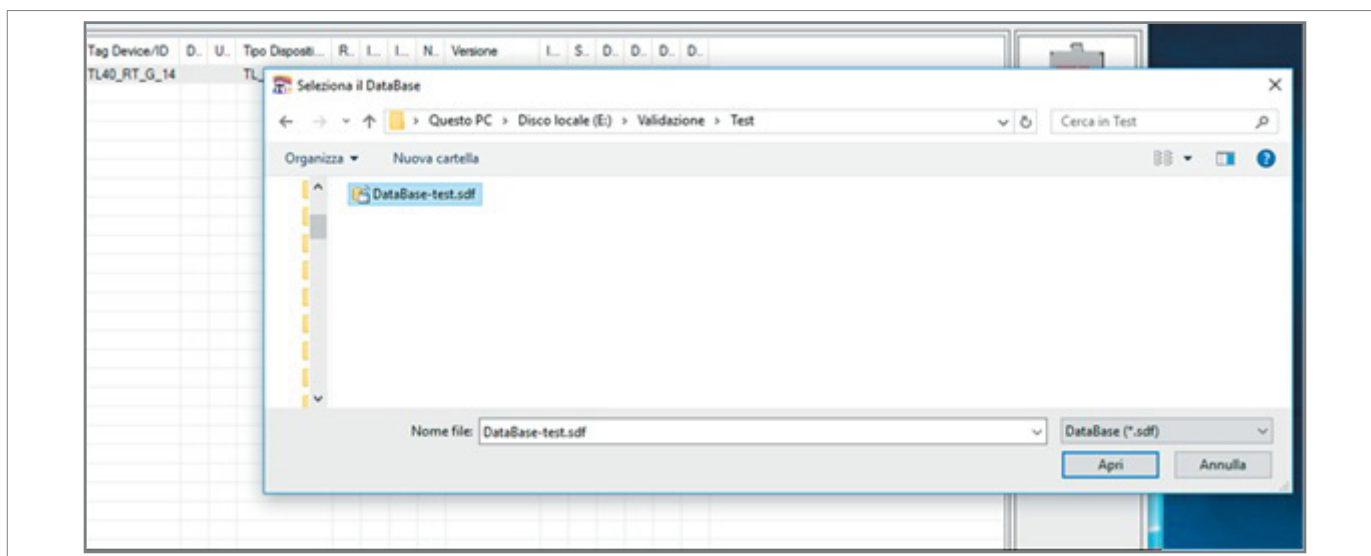

Fig. 8.26. Files .sdf

3. Check the programme screen for the correct file extension

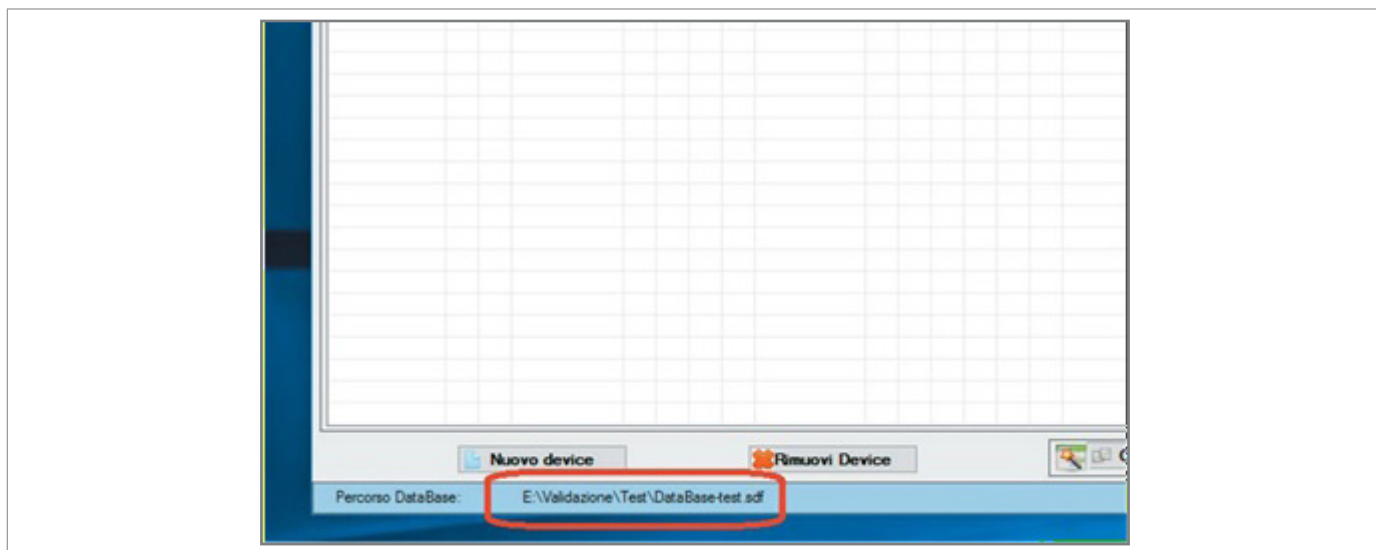

Fig. 8.27. Database verification

8.3 - RTU INTERFACE

After selecting the RTU from the initial list, the system will display the following screen:

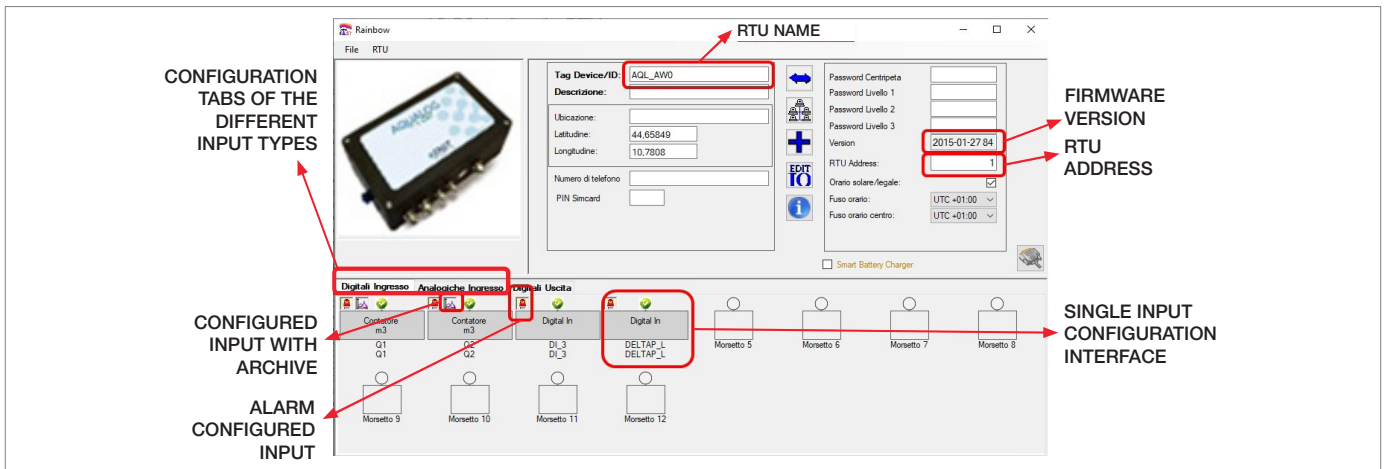

Fig. 8.28. RTU configuration

The following parameters can be configured on this page:

- Digital/analogue inputs.** By clicking on the individual boxes associated with the inputs, it is possible to configure and enable the chosen analogue/digital input.
- RTU address.** In the 'RTU Address' field, the address paired with the RTU can be changed. *Default Values:* 1.
- RTU Name.** The RTU can be given a name so that it can be easily paired with the device on the RAINBOW database. In the example, the name is 'AQL_AW0'.

Once this is done, the configuration can be sent to the RTU by clicking on 'RTU: read/send RTU configuration'.

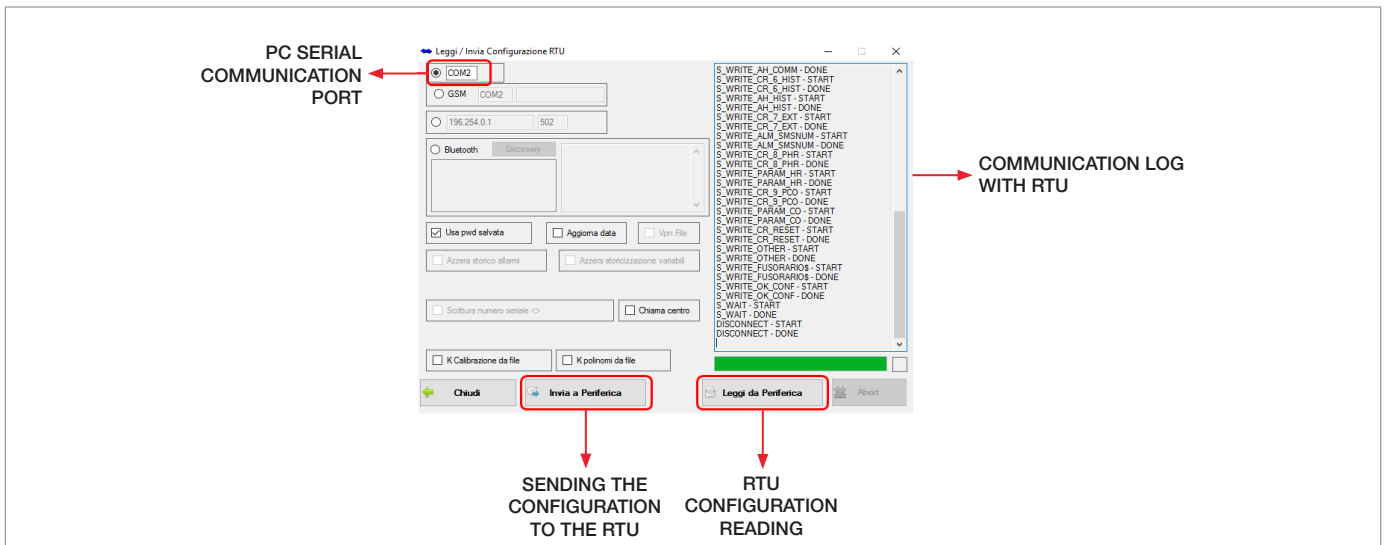

Fig. 8.29. Read/send RTU configuration

To send the configuration, refer to the USB connection procedure in "5.1 - Local communication interface".

8.3.1 - ANALOGUE INPUTS

The analogue input configuration page allows the input channel parameters to be set.

On this page, the engineering value of the measurement can be displayed either on the Aqualog-AW display or via local communication panel. Individual channels can be customised by setting a TAG and a photo.

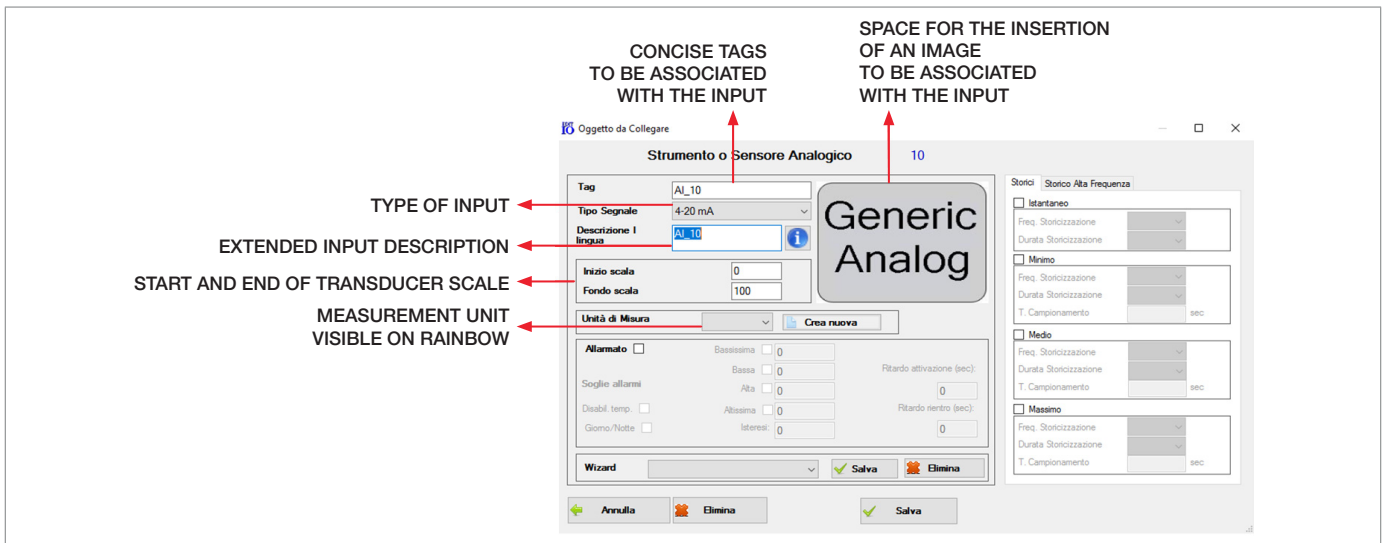

Fig. 8.30. Analogue input configuration

8.3.2 - DIGITAL INPUTS

The digital input configuration page allows you to set an alarm on the chosen input, defining polarity and delay. Individual channels can be customised by setting a TAG and a photo.

The ten digital inputs can be configured as meters. These types of variables count the number of state changes on the selected input. Flow calculation is only enabled for the first six inputs configured as meters.

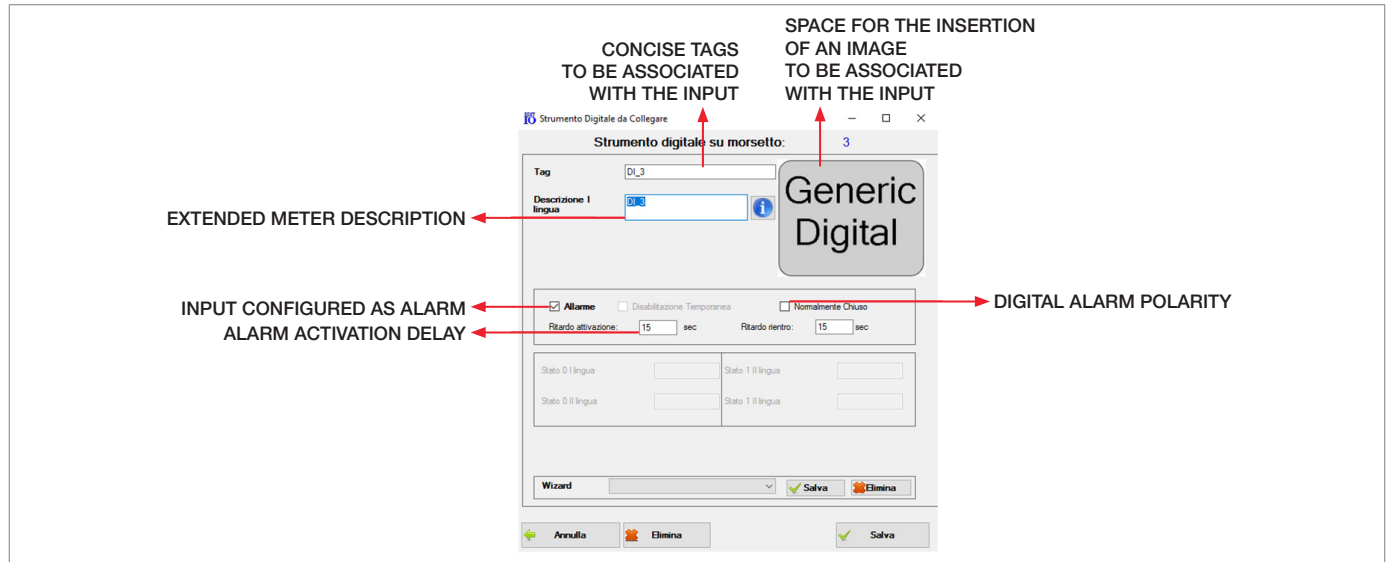

Fig. 8.31. Digital input configuration

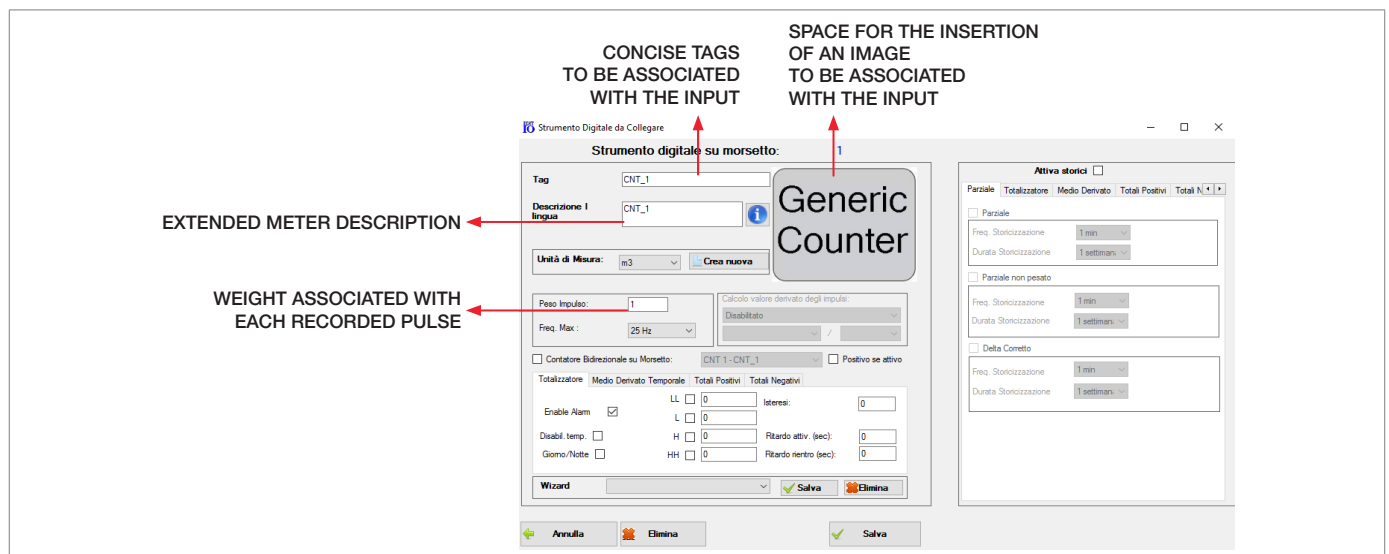

Fig. 8.32. Meter configuration

8.3.2.1 - UPDATING METERS

The value of the machine's meters can be updated in the 'Init Settings' tab:

Step	Action
1	Select the relative meter.
2	Change the meter value.
3	Click the 'Meter Preset' button.
4	Wait for the pop-up message confirming the completion of the operation.

Tab. 8.39.

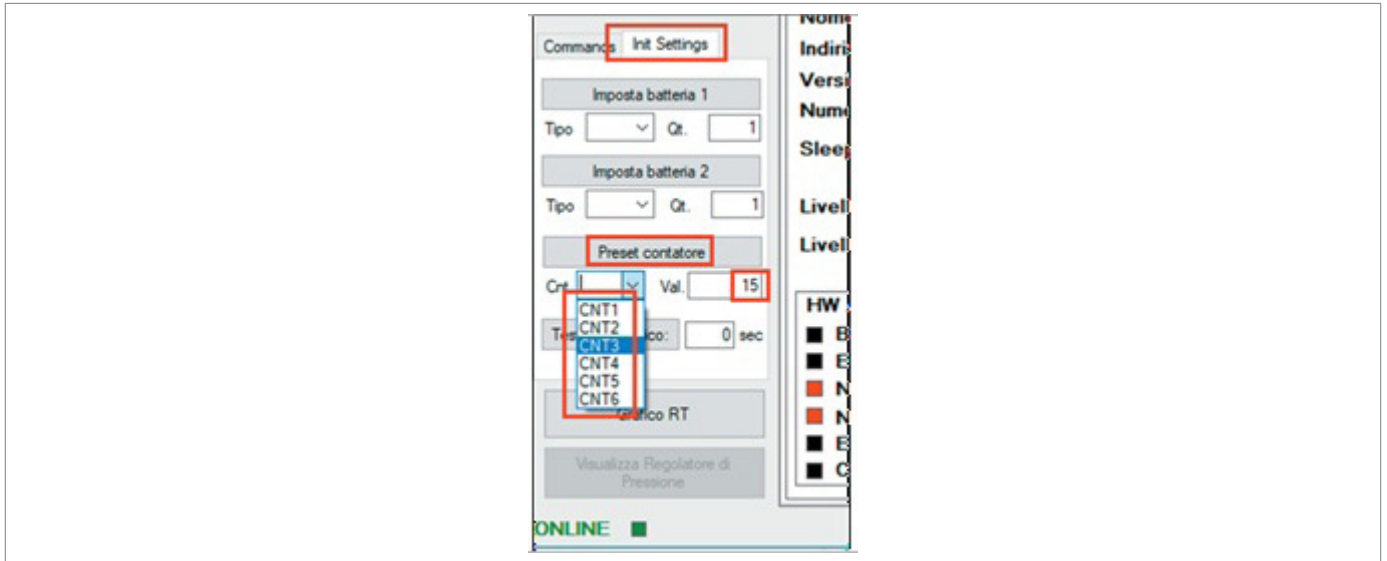

Fig. 8.33. Meter preset window

8.3.3 - DATALOGGER

The input variables, both analogue and calculated on the counting inputs (e.g. flow rates), can be logged according to four different strategies:

- Current value.
- Minimum value.
- Medium value.
- Maximum value.

For each, the storage time interval is configurable. For the minimum, average, maximum modes, it is also possible to configure the calculation period (sampling time). The digital input variables are stored on state change.

The archive depth is configurable and is generally set to 2 weeks.

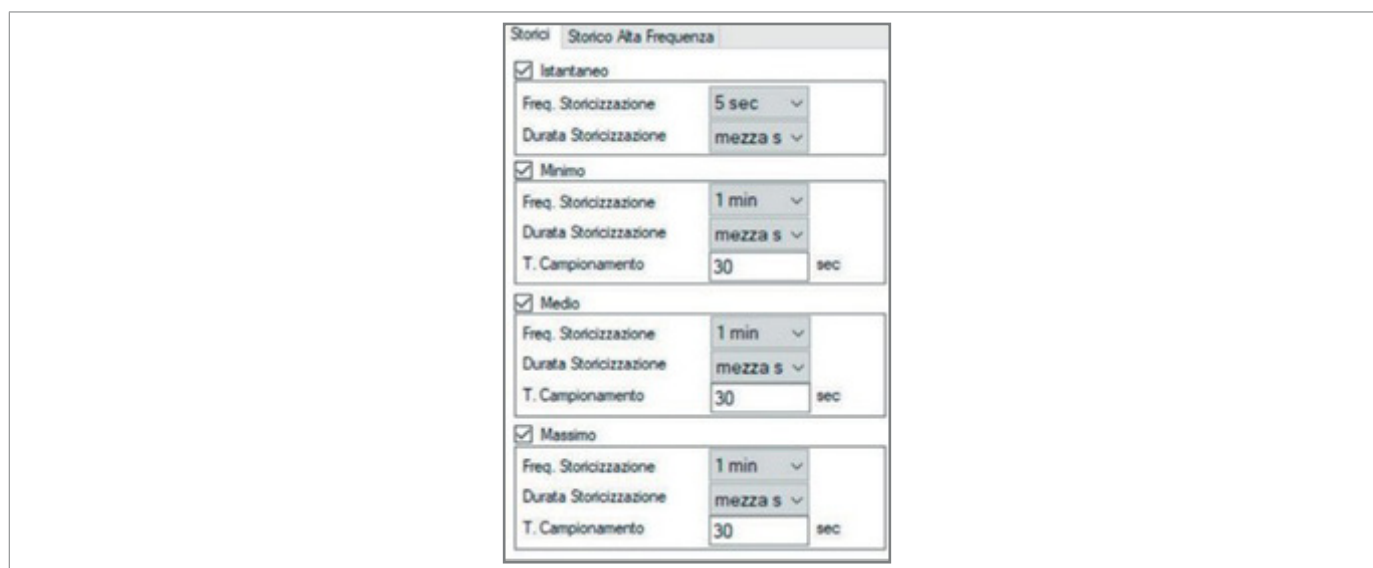

Fig. 8.34. Analogue variable historian mode

The historisation capacity of the device depends on the frequency and duration of the historisation.

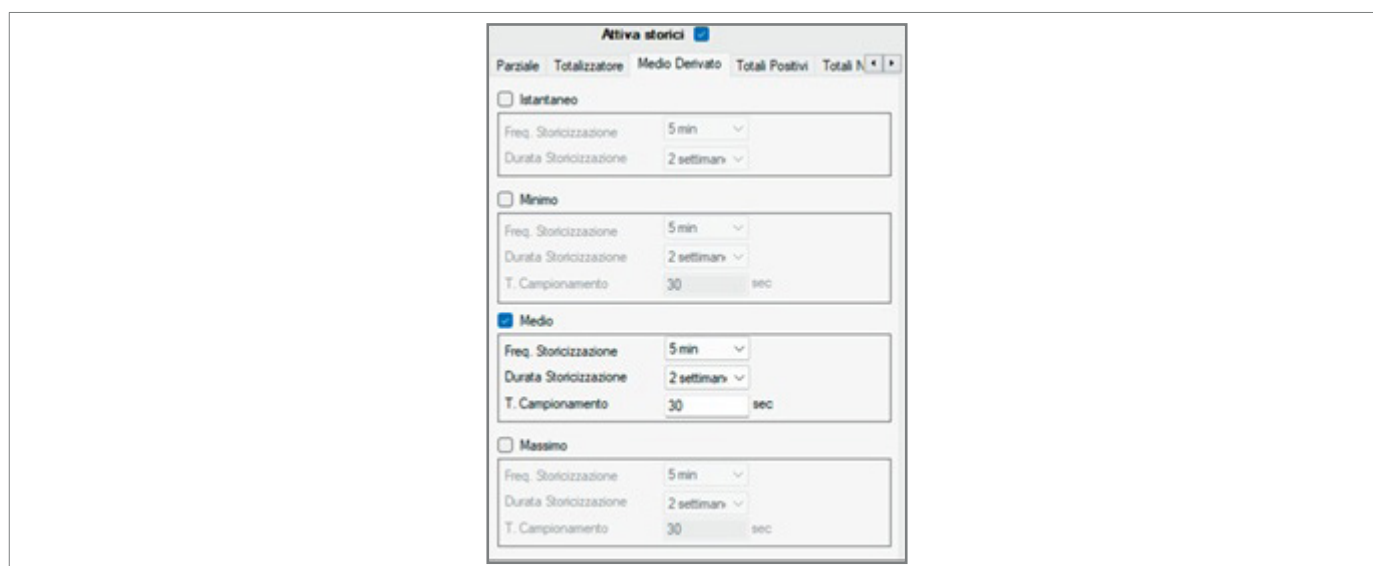
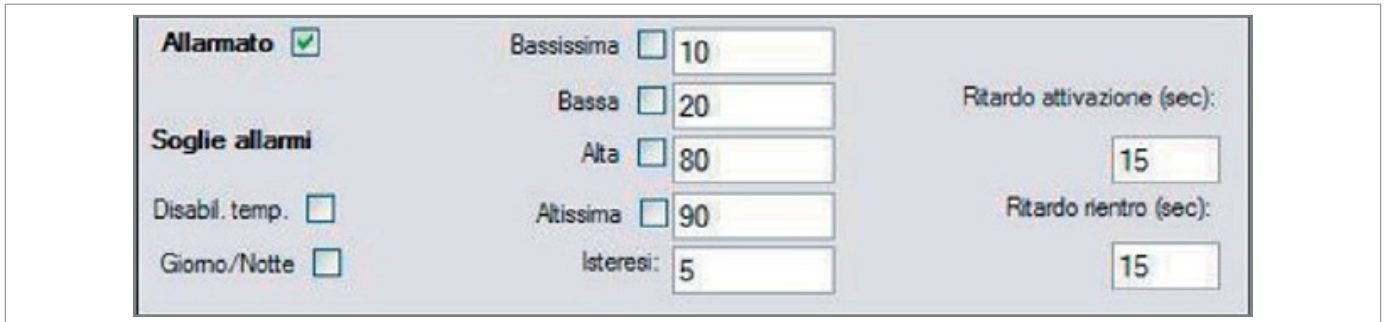

Fig. 8.35. Calculated variables historicisation mode

8.3.4 - ENABLING ALARMS ON INPUTS

Input variables, both analogue and counting inputs (e.g. flow rates), can be alarmed and thus configured for alarm triggering.

For analogue variables there are 2 minimum thresholds (very low, low) and 2 maximum thresholds (high, very high) with possible activation and clearing delays.



The screenshot shows the 'Soglie allarmi' (Alarm thresholds) configuration for an analogue measure. It includes the following fields:

- Alarmato:**
- Soglie allarmi:**
 - Bassissima: 10
 - Bassa: 20
 - Alta: 80
 - Altissima: 90
 - Isteresi: 5
- Disabil. temp.:**
- Giorno/Notte:**
- Ritardo attivazione (sec):** 15
- Ritardo rientro (sec):** 15

Fig. 8.36. Alarm configuration on analogue measure

By enabling the Day/Night mode it is possible to have different threshold sets for day and night. The day/night threshold changeover time can be set in the RTU menu under 'Alarm Configuration'. Hysteresis is expressed in engineering units and defines the deviation of the signal value from the threshold for alarm return.

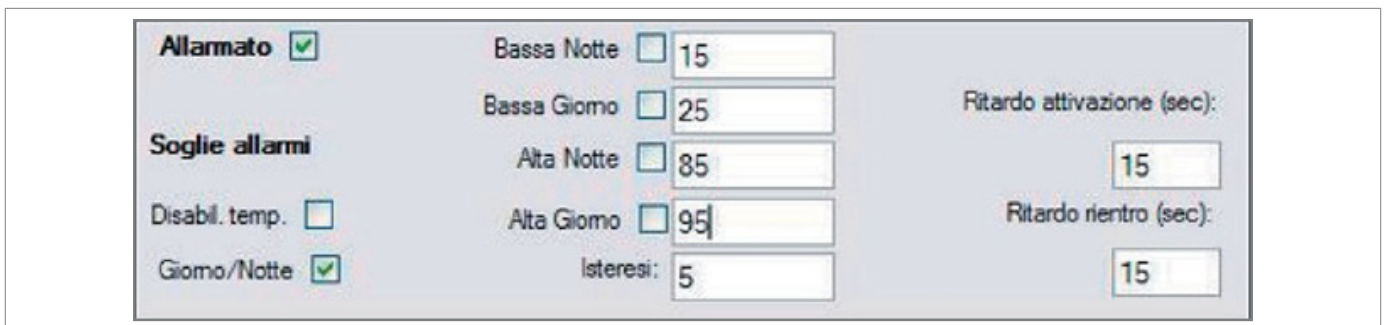

The screenshot shows the 'Soglie allarmi' configuration for an analogue measure in Day/Night mode. It includes the following fields:

- Alarmato:**
- Soglie allarmi:**
 - Bassa Notte: 15
 - Bassa Giorno: 25
 - Alta Notte: 85
 - Alta Giorno: 95
 - Isteresi: 5
- Disabil. temp.:**
- Giorno/Notte:**
- Ritardo attivazione (sec):** 15
- Ritardo rientro (sec):** 15

Fig. 8.37. Day/night mode alarm configuration on analogue measure

Alarms can also be configured on digital signals. The alarm status (NO or NC) and the activation and re-entry delays are definable by the operator.

The RTU records the activation and re-entry from each alarm in a specific log in its internal memory. This information can be downloaded locally via the RAINBOW software or remotely via the SCADA centre.



The screenshot shows the configuration for digital signals. It includes the following fields:

- Alarme:**
- Disabilitazione Temporanea:**
- Normalmente Chiuso:**
- Ritardo attivazione:** 10 sec
- Ritardo rientro:** 10 sec

Fig. 8.38. Alarm configuration on digital signals

Alarms can also be configured on calculated input variables such as pulse-derived flow rate.

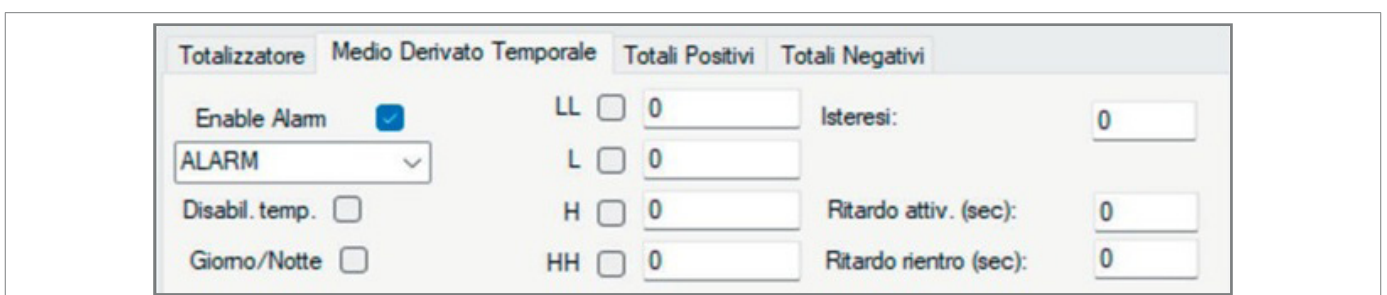

The screenshot shows the configuration for pulse-derived flow rate alarms. It includes the following fields:

- Totalizzatore:** Selected
- Enable Alarm:**
- ALARM:** Dropdown menu
- Disabil. temp.:**
- Giorno/Notte:**
- LL:** 0
- L:** 0
- H:** 0
- HH:** 0
- Isteresi:** 0
- Ritardo attiv. (sec):** 0
- Ritardo rientro (sec):** 0

Fig. 8.39. Configuration on pulse-derived flow rate alarms

8.4 - CONFIGURATION OF 2G/3G COMMUNICATION PARAMETERS

By navigating to 'RTU → Communication' it is possible to connect the RTU with the SCADA via the 2G/3G/4G modem by setting the following connection parameters:

Step	Action
1	Set the mode 'GPRS always off' in the 'Outbound' section.
2	Set the IP and port of the centre of interest in the 'Inbound' section.
3	Set the number of attempt greater than 0.
4	Set on 'GPRS settings' the APN parameters, network username and password.
5	Set the communication protocol and its parameters.
6	Click 'OK' and confirm the change of data.

Tab. 8.40.

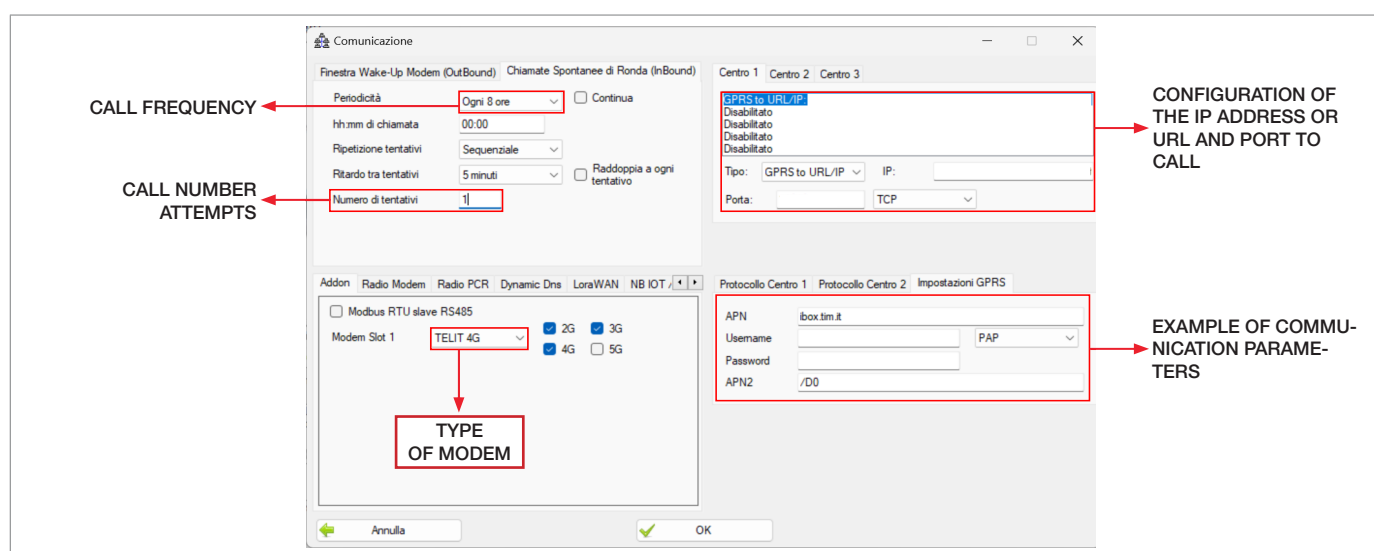

Fig. 8.40. Configuration of connection parameters for RTU with 2G/3G call

8.5 - LOCAL COMMUNICATION

By navigating to 'RTU → Monitor Diagnostics', the local communication interface between RTU and PC can be used. This tool allows Real-Time monitoring of the machine status and all configured inputs.

To connect to the RTU, follow the connection procedure with USB, Wi-Fi or Bluetooth in “5.1 - Local communication interface” and click the "**Connect**" button.

When the white box in the bottom left-hand corner turns green, the software is connected to the machine.

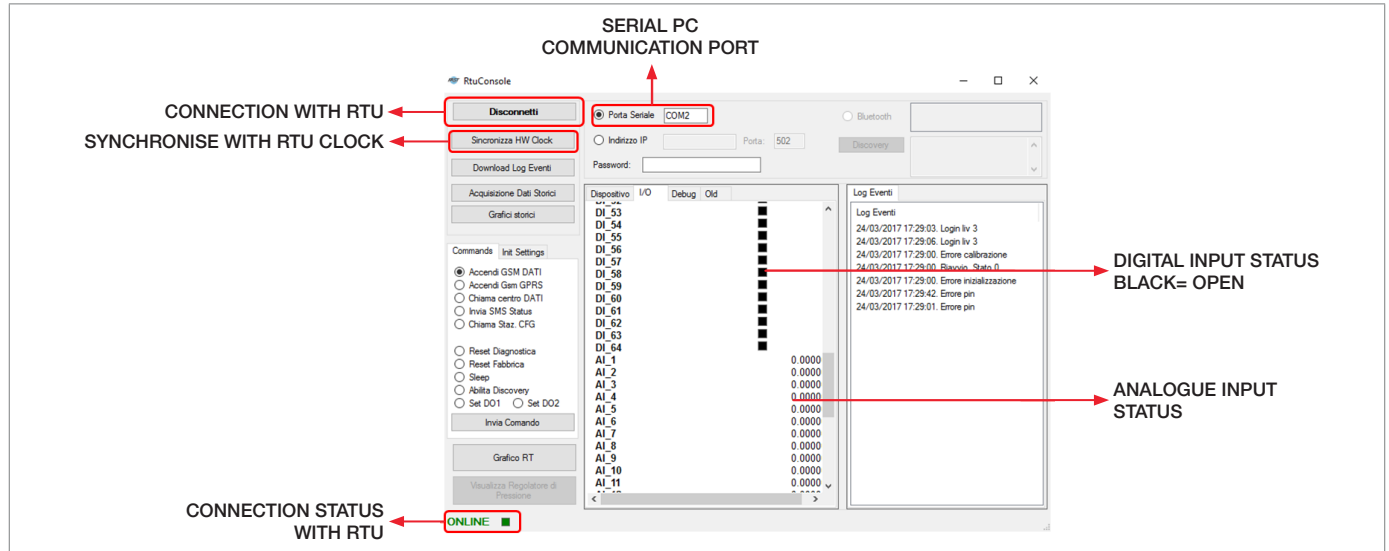

Fig. 8.41. Local communication with RTU

8.6 - BATTERY UPGRADE

By browsing to 'RTU → Diagnostic Monitor', it is possible to initialise the remaining battery value:

Step	Action
1	Select 'Init Settings'
2	Select 'Type' and 'Qt', then click 'Set battery 1' to initialise the RTU battery.
3	Select "Type" and "Power (W)", "Voltage (V)" of the solenoid used, then click "Init Pilot Box battery" to initialise the Pilot Box battery.

Tab. 8.41.

Example:

- 4-cell battery: select "Type: 13 Ah" and "Qt: 6" to initialise an 80 Ah battery.
- 7-cell battery: select "Type: 13 Ah" and "Qt: 11" to initialise an 140 Ah battery.

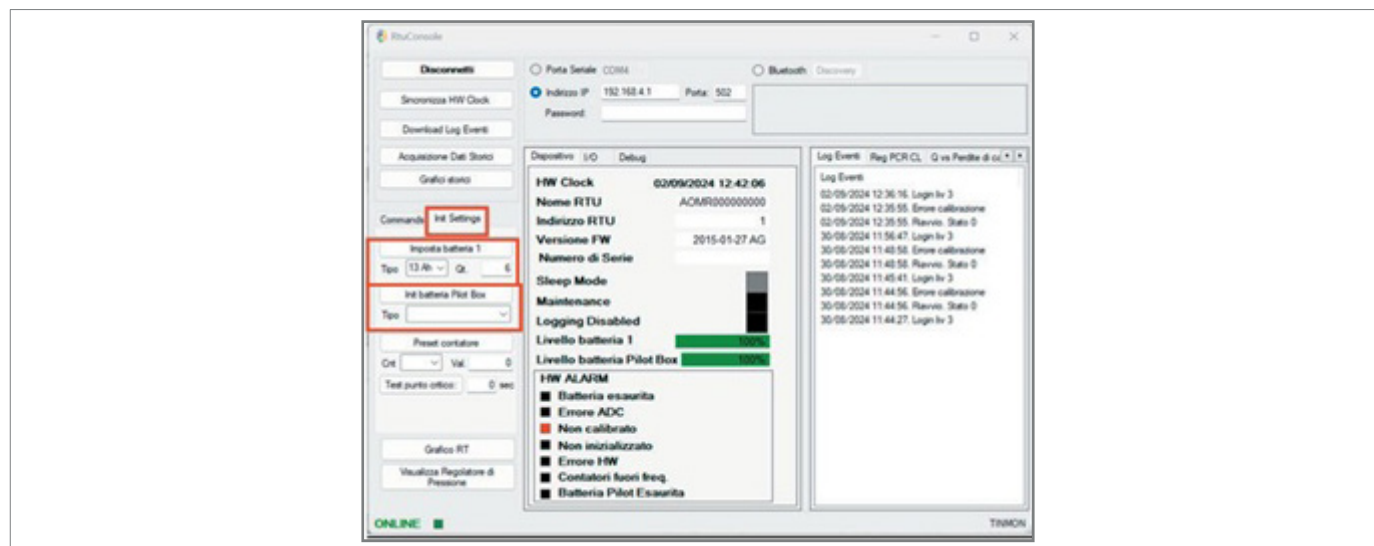

Fig. 8.42. Battery initialisation screen

8.7 - ALARM ACTION

By browsing to 'RTU → Alarms Action', it is possible to configure the operations to be performed in the event of an analogue or digital alarm. Each type of alarm can be paired with several possible operations. Changes require the device to be reconfigured.

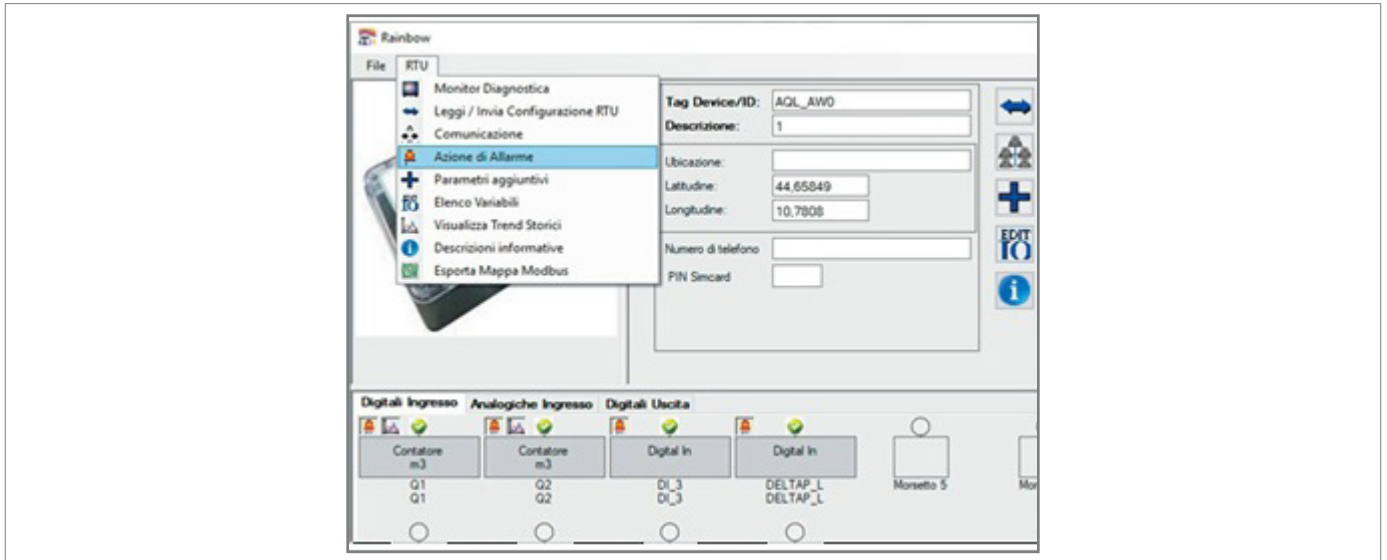

Fig. 8.43. Alarms action configuration screen

8.7.1 - ADDING AN ALARM ACTION

In order to add a new alarm action, the following steps must be followed:

Step	Action
1	Select the Aqualog-AW to be configured from the Rainbow start page.
2	Select the 'RTU' menu at the top left of the AQUALOG T-CNT page.
3	Select ' Alarm Action ' in the menu.
4	On the new page there should only be the 'Call Centre' entry.
5	Pair the measurement to be monitored with centre call to the new alarm action.
6	Set number of attempts and interval of call repetition attempts.
7	Press 'Save' at the bottom left.
8	Send the configuration.

Tab. 8.42.

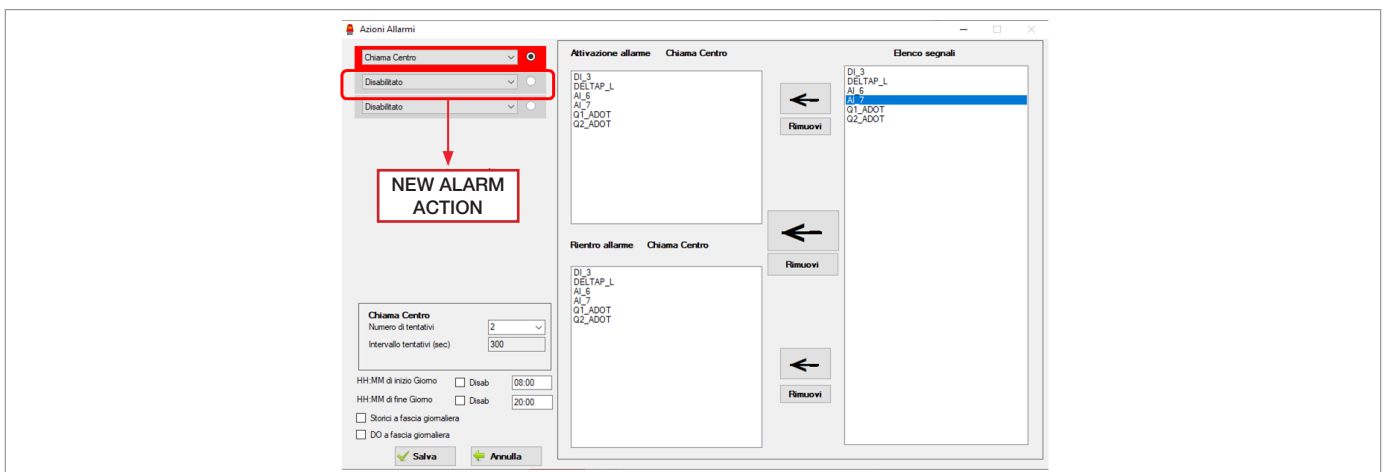

Fig. 8.44. New alarm action selection

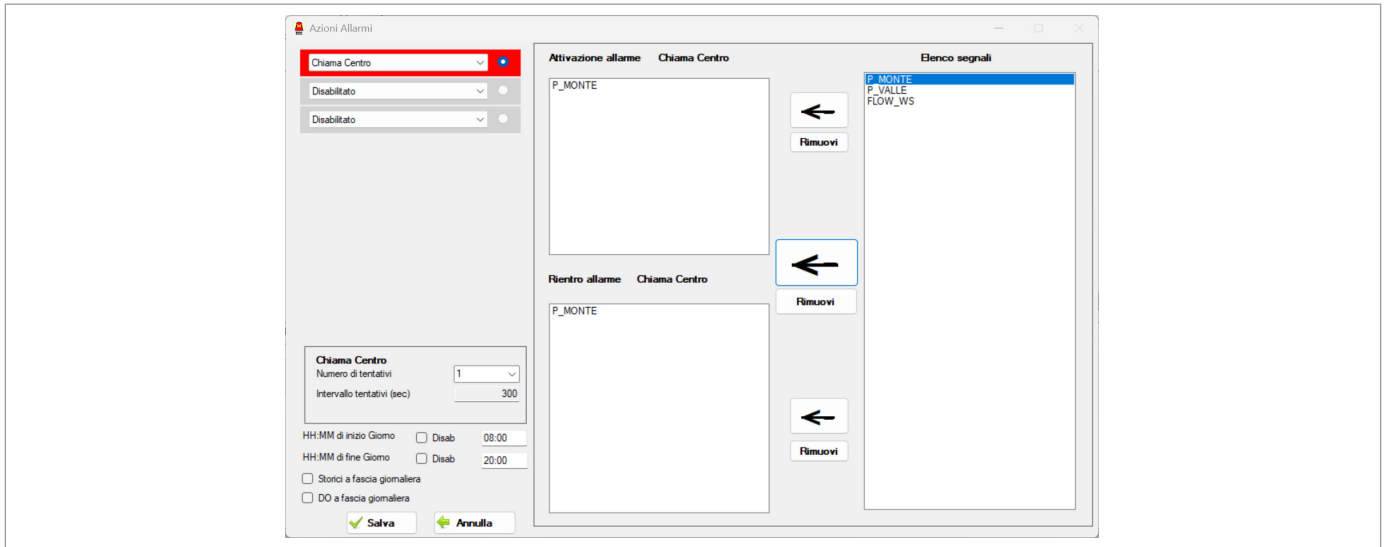

Fig. 8.45. New alarm action configuration

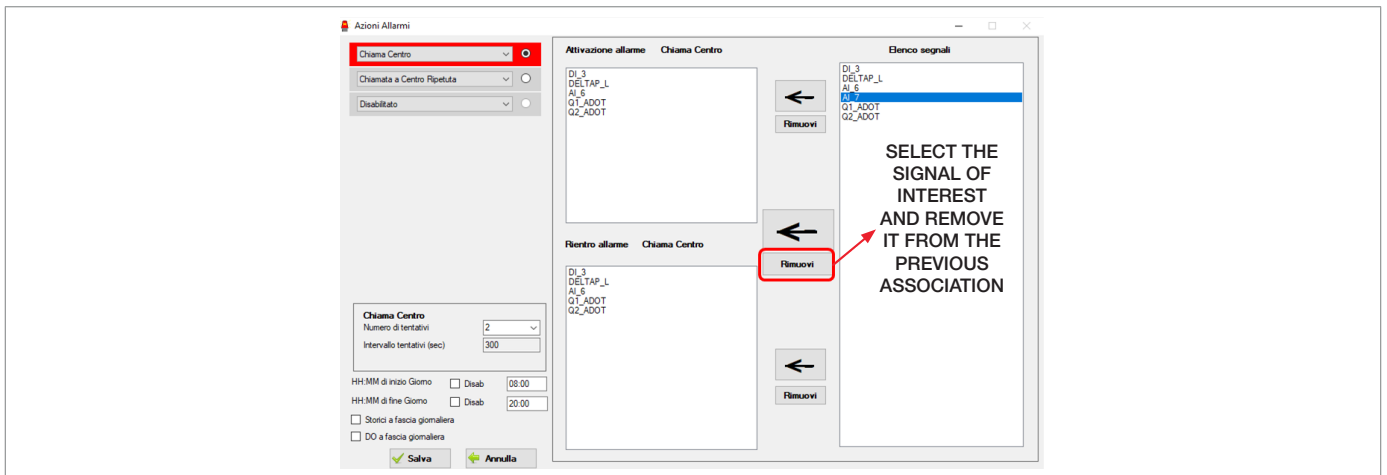

Fig. 8.46. Previous alarm action removing

8.8 - 2G, 3G DATA CALL COMMUNICATION TEST

1. Double-click on the configuration from the list on the 'Rainbow' screen.
2. Activate the local USB connection, refer to section “5.1 - Local communication interface”.
3. Select 'Diagnostic Monitor' from the RTU menu at the top left:

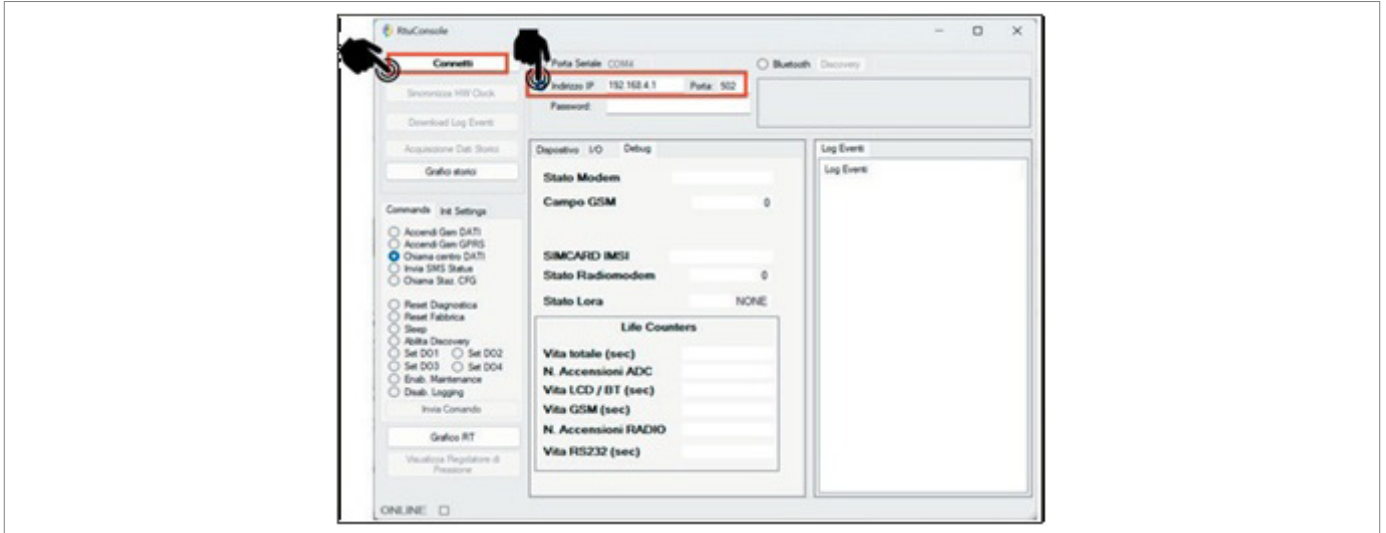

Fig. 8.47. Diagnostic monitor selection

4. Select the Serial Port communication channel and then click on 'Connect'.

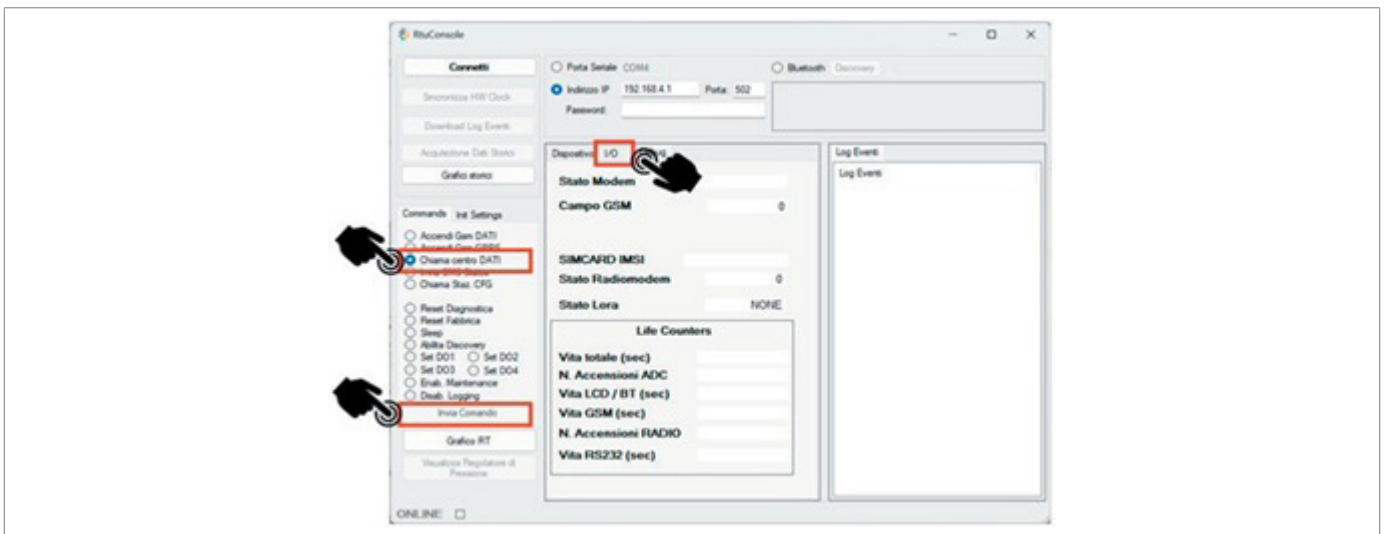

Fig. 8.48. Connection

5. Select “Call DATA Centre”, then “Send Command”.

6. Check the modem status from the 'Debug' window.
7. Verify on the display that the system performs the steps in the 'Diagnostic monitor debugging' section (refer to Tab. 8.43):

Step	Modem status
Switch-on	Modem in switch-on
Network registration	Modem in provider cell registration
GPRS registration	Attempt to touch on the APN
GPRS call	Attempt to access the centre
Data Exchange	Send packets to the centre
Connection closure	Communication closure

Tab. 8.43.

NOTICE!

This can also be checked from the RTU display in the 'Modem' section.
The 'Data Exchange' step displays the progress of packets 'PKT GPRS 1...'.

8.9 - RESET

RESET FACTORY: clears the internal RTU configuration while maintaining the calibration of the analogue acquisition channels:

Step	Action
1	Connect the USB cable to the RTU.
2	Run the 'Rainbow' software.
3	Select an AQUALOG T-CNT RTU.
4	Click the "RTU → Diagnostic Monitor" button.
5	Select the COM port paired with the USB cable and click 'Connect'.
6	Wait for the connection.
7	Select the 'Factory Reset' item and click the 'Send command' button.
8	Wait for the message 'Reset in progress'.
9	Log off.

Tab. 8.44.

PAGE INTENTIONALLY LEFT BLANK

9 - MAINTENANCE AND FUNCTIONAL CHECKS

9.1 - GENERAL WARNINGS

HAZARD!

- Maintenance work must be carried out by qualified personnel trained on safety in the workplace and authorised to carry out equipment-related activities.
- Repair or maintenance work not provided for in this manual may be carried out only if approved by PIETRO FIORENTINI S.p.A.. PIETRO FIORENTINI S.p.A. shall not be held liable for damage to persons or property resulting from operations other than those described herein or carried out in ways other than as indicated.

HAZARD!

Special maintenance:

- requires extensive and specialised knowledge of the machines, operations required, risks involved and correct procedures to operate safely;
- must be provided by qualified, trained and authorised technicians.

WARNING!

In case of doubt, do not perform any work.

Contact PIETRO FIORENTINI S.p.A. for the necessary clarifications.

NOTICE!

Before starting maintenance on the equipment, it is advisable to make sure that the authorised operator has:

- the necessary equipment;
- appropriate spare parts.

Operate as described in Tab. 9.45. in case of anomalies detected in the equipment, which require its removal and replacement from the field:

Step	Action
1	Switch off the main power switch upstream of the device (in the case of a device powered from the 230VAC mains).
2	Unscrew and remove the cover screws.
3	Open the cover.
4	Disconnect the batteries.
5	Disconnect the cables of any sensors or measurements wired to the instrument.
6	Disassemble the device.
7	Contact PIETRO FIORENTINI S.p.A.

Tab. 9.45.



The equipment maintenance operations are divided, from an operational point of view, into two main categories:

Commissioning and maintenance operations	
Routine maintenance	All those operations that the operator must preventively carry out to ensure proper operation of the device over time. <div style="border: 1px solid #00a651; padding: 5px; margin-top: 10px;">  NOTICE! The equipment does not require routine maintenance. </div>
Special maintenance	All those operations to be carried out by the operator as required by the equipment.

Tab. 9.46.

9.2 - SPECIAL MAINTENANCE

9.2.1 - REPLACING THE BATTERIES

Replacing batteries	
Operator qualification	<ul style="list-style-type: none"> Specialised technician. Maintenance Technician.
PPE required	<div style="display: flex; align-items: center; gap: 10px;">  </div> <div style="background-color: #f9a825; padding: 5px; margin-top: 5px;">  WARNING! </div> <p>The PPE listed in this table is related to the risk associated with the equipment. For the PPE required to protect against risks associated with the workplace, installation or operating conditions, please refer to:</p> <ul style="list-style-type: none"> the regulations in force in the country of installation; any information provided by the Safety Manager at the installation facility.
Equipment required	Allen key, 6 mm.

Tab. 9.47.

HAZARD!

Batteries, especially end-of-life (exhausted) batteries, are dangerous and sensitive to shock, vibration and exposure to naked flames. Failure to comply with this document may lead to the risk of explosion, fire, harmful emissions which may have serious consequences for health.

ATTENTION!

Use only battery packs supplied by PIETRO FIORENTINI S.p.A.

ATTENTION!

All operations must be carried out:

- in the absence of an explosive atmosphere;
- away from heat sources;
- in a place protected from bad weather;
- as far as possible from water sources that could cause a reaction with the lithium contained inside the batteries.

 ATTENTION!

Operators should not wear jewellery or metal ornaments (rings, necklaces, bracelets and earrings) that may come into contact with electronic components and/or battery terminals to avoid potential short circuits.

 ATTENTION!

The fire extinguishers to be used in the event of a fire must be of class D as they are effective in extinguishing fires in the presence of lithium.

 ATTENTION!

The transport of the battery packs supplied by PIETRO FIORENTINI S.p.A. must be carried out using the original packaging, which complies with the current ADR regulations.

 ATTENTION!

After replacing a battery, it is necessary to realign the remaining battery life indicators.

To **replace the battery pack**, proceed as described below:

Step	Action
1	Unscrew and remove the clamping screws.
2	Remove the cover.
3	Disconnect the battery connector from the housing (A) and take the battery (B) out of the compartment. ⚠ ATTENTION! Store the replaced communication battery in ADR compliant packaging.
4	Insert the connector of the new communication battery into the housing (A). ! NOTICE! Position the cables (C) in such a way that the equipment can be closed.
5	Fit the cover.
6	Insert and secure the clamping screws.

Tab. 9.48.

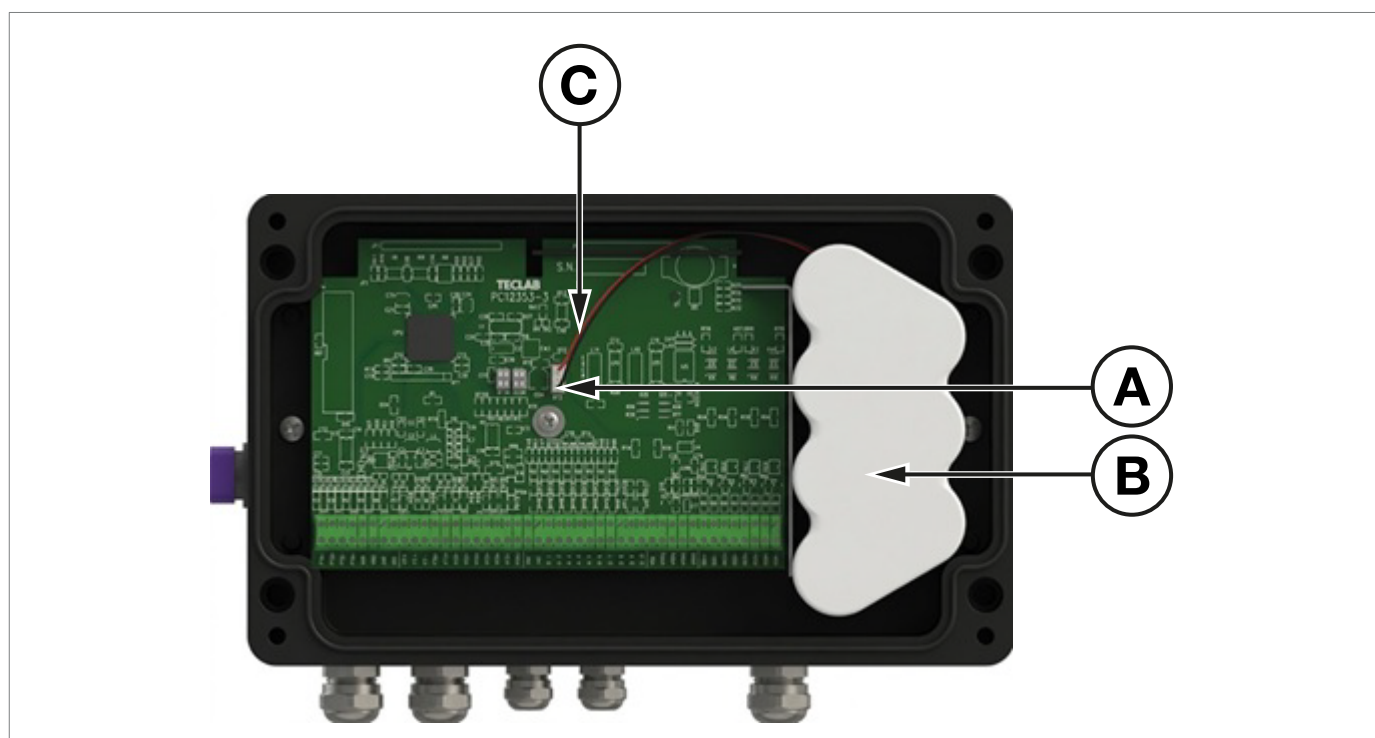

Fig. 9.49. Replacing the battery pack

10 - UNINSTALLATION AND DISPOSAL

10.1 - GENERAL SAFETY WARNINGS

HAZARD!



Make sure that there are no potentially explosive ignition sources in the work area set up to uninstall and/or dispose of the equipment.

WARNING!

Before proceeding with uninstallation and disposal, make the equipment safe by disconnecting it from any power supply.

10.2 - QUALIFICATION OF THE OPERATORS IN CHARGE

Uninstallation

Operator qualification	<ul style="list-style-type: none"> Installer.
PPE required	 <p> WARNING!</p> <p>The PPE listed in this table is related to the risk associated with the equipment. For the PPE required to protect against risks associated with the workplace, installation or operating conditions, please refer to:</p> <ul style="list-style-type: none"> the regulations in force in the country of installation; any information provided by the Safety Manager at the installation facility.
Equipment required	Keys to fix inlet and outlet connections fittings/equipment.

Tab. 10.49.

10.3 - INFORMATION REQUIRED IN CASE OF NEW INSTALLATION

NOTICE!

Should the equipment be reused after uninstallation, refer to chapters: "Installation" and "Configuration".

10.4 - STORAGE OF THE BATTERIES

NOTICE!

Refer to paragraph 6.6.1 to store the batteries.

10.5 - INFORMATION REQUIRED IN CASE OF RE-INSTALLATION

NOTICE!

Refer to chapter 7 "Installation" if the equipment is to be reused after uninstallation.

10.6 - DISPOSAL INFORMATION

NOTICE!

- **Proper disposal prevents damage to humans and the environment and promotes the reuse of precious raw materials.**
- **Bear in mind that the regulations in force in the country of installation must be complied with.**
- **Illegal or improper disposal involves the application of the penalties provided for by the regulations in force in the country of installation.**

The equipment was manufactured with materials that can be recycled by specialised companies. For proper disposal of the equipment, proceed as specified in Tab. 10.50:

Step	Action
1	Set up a large work area free from obstacles where to safely dismantle the equipment.
2	Sort the various components by type of material for easier recycling through separate collection.
3	Send the materials obtained in Step 2 to a specialised company.

Tab. 10.50.

The equipment in any configuration consists of the materials described in Tab. 10.51:

Material	Disposal/recycling indications
Plastic	It must be dismantled and disposed of separately
Steel	Disassemble and collect separately. It must be recycled through the specific collection centres.
Stainless steel	Disassemble and collect separately. It must be recycled through the specific collection centres
Aluminium	Disassemble and collect separately. It must be recycled through the specific collection centres
Electronic components	Disassemble and collect separately. It must be recycled through the specific collection centres.
Lithium batteries	Consult paragraph "10.1 - Disposing of the batteries".

Tab. 10.51.

NOTICE!

The above materials refer to standard versions. Different materials can be provided for specific needs.

10.7 - DISPOSING OF THE BATTERIES

Proceed with disposal in compliance with the requirements:

- the transport and packaging requirements given in the chapter;
- of the legislation in force in the country of installation of the equipment.

WARNING!

When disposing of the batteries, they must be removed from the equipment, as indicated in Directive 2006/66/EC art.12 paragraph 3.

The transport of batteries to the intermediate treatment facilities is not subject to the provisions of ADR, if:

- a quality assurance system is implemented to ensure that the total quantity of lithium cells and batteries per transport unit does not exceed 333 kg (the total quantity of lithium cells and batteries in the batch can be determined by a statistical method included in the quality assurance system);
- a copy of the quality assurance records must be made available to the competent authority if it so requests).

NOTICE!

You can ship batteries and/or batteries for recycling or disposal under a partial exemption scheme, in accordance with special provision 636.

This exemption applies to lithium batteries/batteries of gross mass \leq 500 g per unit.

10.7.1 - BATTERY PACKAGING

NOTICE!

The packages must be labelled in accordance with ADR, i.e. with a diamond shape on the side and code UN3090.



NOTICE!

The packages must bear the indication "LITHIUM BATTERIES FOR DISPOSAL" or "LITHIUM BATTERIES FOR RECYCLING".

The batteries that are removed from the equipment must be packed in such a way:

- to be protected from any damage due to transport and handling;
- to prevent any accidental movement;
- to prevent the terminals from bearing the weight of other elements;
- to be protected from short circuits.

For this purpose, the original packaging or alternatively, packaging compliant with the ADR regulations, can be used.

If batteries not removed from the equipment but still inside it are transported, the packaging may not be approved but must still be:

- sufficiently robust and able to contain and protect the equipment;
- constructed in such a way as to prevent the equipment from operating accidentally during transport.

PAGE INTENTIONALLY LEFT BLANK

11 - RECOMMENDED SPARE PARTS

11.1 - GENERAL WARNINGS

NOTICE!

If spare parts not recommended are used, PIETRO FIORENTINI S.p.A. their declared performance cannot be guaranteed.

It is recommended to use original spare parts PIETRO FIORENTINI S.p.A.

PIETRO FIORENTINI S.p.A. shall not be held liable for any damage caused by using non-original parts.

11.2 - HOW TO REQUEST SPARE PARTS

NOTICE!

For specific information, please refer to the sales network of PIETRO FIORENTINI S.p.A.

11.3 - PUTTING BACK BATTERIES

Reference to the spare batteries order codes:

Features	Type	Supply
4-cell battery	Li-SOCI2	Standard
7-cell battery	Li-SOCI2	Optional

Tab. 11.52.

TM0258ENG

