

Serie FEX

Low-pressure gas regulator



Revision A - Edition 05/2024

**USE, MAINTENANCE
AND WARNING
INSTRUCTIONS**

PAGE INTENTIONALLY LEFT BLANK

1 - INTRODUCTION

FOREWORD

All rights reserved. No part of this publication may be reproduced, distributed, translated into other languages or transmitted by any electronic or mechanical media, including photocopies, recording or any other storage and retrieval system, for any other purposes that are not exclusively the personal use of the buyer, without the express written permission of the Manufacturer.

The manufacturer is in no way responsible for the consequences of operations carried out in a manner not in accordance with the manual.

GENERAL REMARKS

All the operating, maintenance instructions and recommendations described in this manual must be adhered to in order to:

- obtain the best possible performance from the equipment;
- keep the equipment in efficient conditions.

Training the personnel in charge is essential in order to:

- properly use the equipment;
- correctly apply the safety alerts and procedures recommended.

Revision: A

PAGE INTENTIONALLY LEFT BLANK

1.1 - REVISION HISTORY

Revision index	Date
A	05/2024

Tab. 1.1.

INDICE

1 - INTRODUCTION	3
1.1 - REVISION HISTORY.....	5
2 - GENERAL INFORMATION	9
2.1 - MANUFACTURER IDENTIFICATION	9
2.2 - IDENTIFICATION OF THE PRODUCT	9
2.3 - REGULATORY FRAMEWORK.....	9
2.4 - WARRANTY	9
2.5 - ADDRESSEES, SUPPLY AND STORAGE OF THE INSTRUCTION MANUAL	10
2.6 - LANGUAGE	10
2.7 - SYMBOLS USED IN THE MANUAL.....	11
2.8 - NAMEPLATES APPLIED	12
2.8.1 - GLOSSARY FOR NAMEPLATES	14
2.9 - GLOSSARY OF MEASUREMENT UNITS.....	15
2.10 - QUALIFIED PROFESSIONAL FIGURES.....	16
3 - SAFETY	17
3.1 - GENERAL SAFETY WARNINGS.....	17
3.2 - PERSONAL PROTECTIVE EQUIPMENT.....	18
3.3 - RESIDUAL RISKS	19
3.3.1 - TABLE SHOWING RESIDUAL RISKS DUE TO PRESSURE	20
3.3.2 - TABLE OF RESIDUAL RISKS FOR POTENTIALLY EXPLOSIVE ATMOSPHERES	22
3.4 - OBLIGATIONS AND PROHIBITIONS	24
3.5 - SAFETY PICTOGRAMS	25
3.6 - RISK LEVEL	25

4 - DESCRIZIONE E FUNZIONAMENTO 27

4.1 - GENERAL DESCRIPTION	27
4.2 - OPERATION.....	28
4.3 - INTENDED USE	29
4.3.1 - ENVISAGED USE	29
4.3.2 - REASONABLY FORESEEABLE MISUSE	29
4.3.3 - TYPES OF FLUIDS	29
4.4 - MODELS AND CONFIGURATIONS	30
4.4.1 - SURFACE TREATMENTS	31
4.5 - TECHNICAL FEATURES/PERFORMANCE	32
4.6 - SAFETY DEVICE	33
4.6.1 - SLAM-SHUT VALVE FOR MINIMUM AND MAXIMUM DOWNSTREAM PRESSURE	33
4.6.2 - RELIEF VALVE.....	34
4.6.3 - PRESSURE OUTLET	35
4.6.3.1 - PROCEDURE OF USE WITH STANDARD PRESSURE OUTLET	36
4.6.3.2 - PROCEDURE OF USE WITH PETERSON MODEL PRESSURE OUTLET	37

5 - TRANSPORT AND HANDLING 39

5.1 - SPECIFIC WARNINGS FOR TRANSPORT AND HANDLING	39
5.1.1 - PACKAGING AND FASTENERS USED FOR TRANSPORT	40
5.2 - STANDARD FEX PHYSICAL CHARACTERISTICS	41
5.2.1 - PHYSICAL CHARACTERISTICS FEX WITHOUT SLAM-SHUT VALVE	42
5.3 - EQUIPMENT ANCHORING AND LIFTING METHOD.....	43
5.3.1 - FORKLIFT HANDLING METHOD.....	44
5.4 - PACKAGING REMOVAL.....	46
5.4.1 - PACKAGING DISPOSAL	46
5.5 - STORAGE AND ENVIRONMENTAL CONDITIONS	47
5.5.1 - STORAGE LASTING LONGER THAN THE MAXIMUM TIME ALLOWED	47

6 - INSTALLATION 49

6.1 - INSTALLATION PRE-REQUISITES.....	49
6.1.1 - ALLOWED ENVIRONMENTAL CONDITIONS.....	49
6.1.2 - STORAGE LASTING LONGER THAN THE MAXIMUM TIME ALLOWED	49
6.1.3 - CHECKS BEFORE INSTALLATION.....	50
6.2 - SPECIFIC SAFETY INSTRUCTIONS FOR THE INSTALLATION STEP	51
6.3 - GENERAL INFORMATION ON THE LINE	52
6.4 - INSTALLATION PROCEDURES.....	53
6.4.1 - POST-INSTALLATION INSTRUCTIONS.....	54
6.5 - EQUIPMENT ADJUSTMENTS	55

7 - COMMISSIONING 57

7.1 - GENERAL WARNINGS	57
7.1.1 - SAFETY REQUIREMENTS FOR COMMISSIONING	57
7.2 - PRELIMINARY PROCEDURES FOR COMMISSIONING	58
7.3 - CALIBRATION OF SAFETY DEVICES	58
7.4 - COMMISSIONING THE REGULATOR	58
7.4.1 - COMMISSIONING OF THE REGULATOR WITH SLAM-SHUT VALVE	59
7.4.2 - COMMISSIONING OF THE REGULATOR WITHOUT SLAM-SHUT VALVE	60
7.5 - PROPER COMMISSIONING CHECK	61
7.6 - RESET OF SAFETY DEVICES AFTER COMMISSIONING	61
7.7 - DRUM ASSEMBLY (UNDERGROUND VERSION OF THE REGULATOR)	62
7.7.1 - DRUM ASSEMBLED TO THE SLAM-SHUT VALVE COVER	62
7.7.1.1 - REGULATOR RESET	63
7.7.2 - DRUM FIXED ON THE SECOND STAGE CONTROL HEAD	64

8 - FUNCTIONAL CHECKS 65

8.1 - GENERAL WARNINGS	65
8.2 - PERIODICALLY CHECKING AND INSPECTING THE EQUIPMENT FOR PROPER OPERATION	66
8.2.1 - FUNCTIONAL CHECKS OF SAFETY DEVICES	66
8.3 - TIGHTENING TORQUES	68

9 - UNINSTALLATION AND DISPOSAL 69

9.1 - GENERAL SAFETY WARNINGS	69
9.2 - QUALIFICATION OF THE OPERATORS IN CHARGE	69
9.3 - UNINSTALLATION	69
9.4 - INFORMATION REQUIRED IN CASE OF NEW INSTALLATION	70
9.5 - DISPOSAL INFORMATION	70

10 - CALIBRATION TABLES 71

10.1 - CALIBRATION TABLES	71
---------------------------------	----

2 - GENERAL INFORMATION

2.1 - MANUFACTURER IDENTIFICATION

Manufacturer	PIETRO FIORENTINI S.P.A.
Address	Via Enrico Fermi, 8/10 36057 Arcugnano (VI) - ITALY Tel. +39 0444 968511 Fax +39 0444 960468 www.fiorentini.com sales@fiorentini.com

Tab. 2.2.

2.2 - IDENTIFICATION OF THE PRODUCT

Equipment	LOW-PRESSURE GAS REGULATOR
Series	FEX
Available models	<ul style="list-style-type: none"> • FEX50 • FEX75 • FEX100

Tab. 2.3.

2.3 - REGULATORY FRAMEWORK

PIETRO FIORENTINI S.P.A. with registered offices in Arcugnano (Italy) - Via E. Fermi, 8/10, declares that the equipment of FEX SERIES described in this manual is designed, manufactured, tested and checked in compliance with the requirements of standards: UNI 11655:2016, UNI EN 16129:2013 where applicable.

NOTICE!

For specific type approvals, see the appropriate section on the Manufacturer's website: <https://www.fiorentini.com>

NOTICE!

The declaration of conformity in its original version is delivered together with the equipment and this manual.

2.4 - WARRANTY

PIETRO FIORENTINI S.P.A. guarantees that the equipment was manufactured using the best materials, with high quality workmanship, and complies with the quality requirements, specifications and performance set out in the order.

The warranty shall be considered null and void and PIETRO FIORENTINI S.P.A. shall not be liable for any damage and/or malfunctions:

- due to any acts or omissions of the purchaser or end-user, or any of their carriers, employees, agents, or any third party or entity;
- in the event that the purchaser, or a third party, makes changes to the equipment supplied by PIETRO FIORENTINI S.P.A. without the prior written approval of the latter;
- in the event of failure by the purchaser to comply with the instructions contained in this manual, as provided by PIETRO FIORENTINI S.P.A.

NOTICE!

The warranty conditions are specified in the commercial contract.

2.5 - ADDRESSEES, SUPPLY AND STORAGE OF THE INSTRUCTION MANUAL

The instruction manual is intended for qualified technicians responsible for operating and managing the equipment throughout its service life.

It contains the necessary information to properly use the equipment and keep its functional and qualitative characteristics unchanged over time. All information and warnings for safe, correct use are also provided.

The instruction manual, as well as the declaration of conformity and/or test certificate, is an integral part of the equipment and must always accompany it whenever it is moved or resold. It is up to the user to keep this documentation intact for reference throughout the lifespan of the equipment.

WARNING!

Removing, rewriting or editing the pages of the manual and their contents is not allowed.

Keep the instruction manual near the equipment, in an accessible place known by all qualified technicians involved in using and running it.

PIETRO FIORENTINI S.p.A. shall not be held liable for any damage to people, animals and property caused by failure to adhere to the warnings and operating procedures described in this instruction manual.

2.6 - LANGUAGE

The original instruction manual was drawn up in Italian.

Any translations into additional languages are to be made from the original instruction manual.

HAZARD!

The translations into other languages cannot be fully verified. If any inconsistency is found, please refer to the original instruction manual.



If inconsistencies are found or the text does not make sense:

- **stop any actions;**
- **immediately contact PIETRO FIORENTINI S.p.A. at the addresses specified in paragraph 2.1.**

WARNING!

PIETRO FIORENTINI S.p.A. shall be held liable for the information provided in the original manual only.

2.7 - SYMBOLS USED IN THE MANUAL

Symbol	Definition
	Symbol used to identify important warnings for the safety of the operator and/or equipment.
	Symbol used to identify information of particular importance in the instruction manual. The information may also concern the safety of the personnel involved in using the equipment.
	Obligation to refer to the manual. Indicates a requirement for the personnel to refer to (and understand) the instruction manual before working with or on the equipment.

Tab. 2.4.

HAZARD!

Alerts to a hazard with a high level of risk, an imminent hazardous situation which, if not prevented, will result in death or severe damage.

WARNING!

Alerts to a hazard with a medium level of risk, a potentially hazardous situation which, if not prevented, may result in death or severe damage.

ATTENTION!

Alerts to a hazard with a low level of risk, a potentially hazardous situation which, if not prevented, could result in minor or moderate damage.

NOTICE!

Alerts to specific warnings, directions or notes of particular concern, that are not related to physical injury, as well as practices for which physical injury is not likely to occur.

2.8 - NAMEPLATES APPLIED







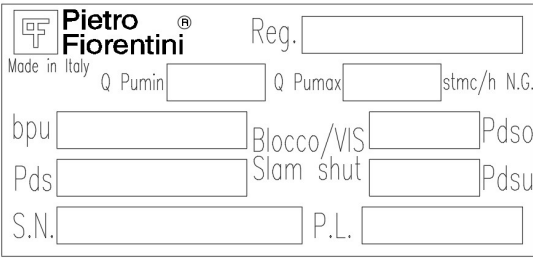

Removing nameplates and/or replacing them with other plates is strictly not allowed.
Should the plates be unintentionally damaged or removed, the customer must notify
PIETRO FIORENTINI S.p.A.

The equipment and its accessories are provided with nameplates (from Id.1 to Id.9).

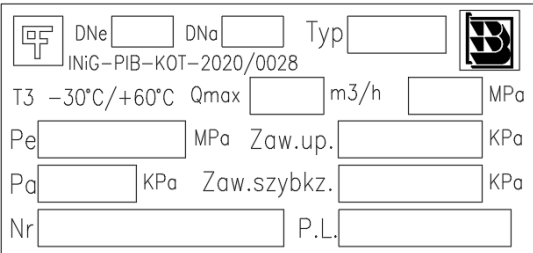
The nameplates specify identification details of the equipment and its accessories to be provided, if necessary, to PIETRO FIORENTINI S.p.A.

List of the nameplates applied:

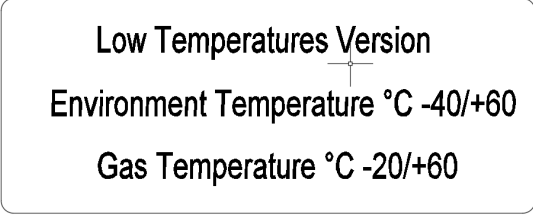
Id.	Type	Image
1	STANDARD LABEL	 <p>Pietro Fiorentini[®] Reg. <input type="text"/> <small>Made in Italy</small> Q P_{um}in <input type="text"/> Q P_{um}ax <input type="text"/> stmc/h N.G. bpu <input type="text"/> Blocco/VIS <input type="text"/> P_{ds}o P_{ds} <input type="text"/> Slam shut <input type="text"/> P_{ds}u S.N. <input type="text"/> P.L. <input type="text"/></p>
2	LABEL FOR RUSSIA	 <p>Pietro Fiorentini[®] Сделано в Италии. Q nom <input type="text"/> С.н. <input type="text"/> bpu <input type="text"/> ПЗК макс <input type="text"/> P_{ds}o P_d <input type="text"/> ПЗК мин <input type="text"/> P_{ds}u материал корпуса: <input type="text"/> ДАТА <input type="text"/></p>
3	LABEL FOR POLAND	 <p> D_{Ne} <input type="text"/> D_{Na} <input type="text"/> Typ <input type="text"/>  <small>INIc-PIB-KOT-2020/0028</small> T3 -30°C/+60°C Q_{max} <input type="text"/> m³/h <input type="text"/> MPa P_e <input type="text"/> MPa Zaw. up. <input type="text"/> KPa P_a <input type="text"/> KPa Zaw. szybkz. <input type="text"/> KPa Nr <input type="text"/> P.L. <input type="text"/></p>
4	LABEL SAFETY DIAPHRAGM	 <p>SAFETY DIAPHRAGM</p>
5	LABEL ARCTIC VERSION	 <p>Low Temperatures Version Environment Temperature °C -40/+60 Gas Temperature °C -20/+60</p>

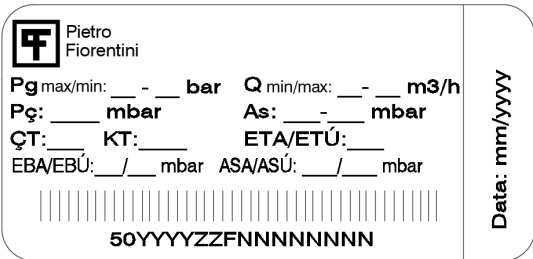
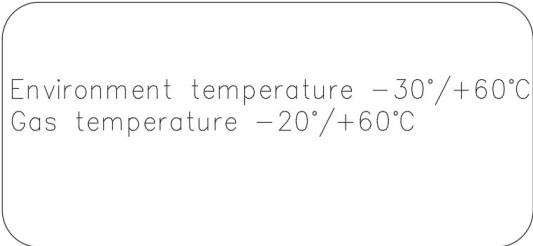
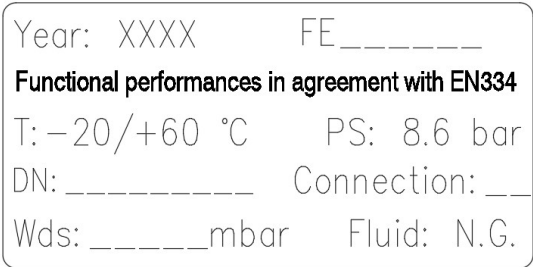
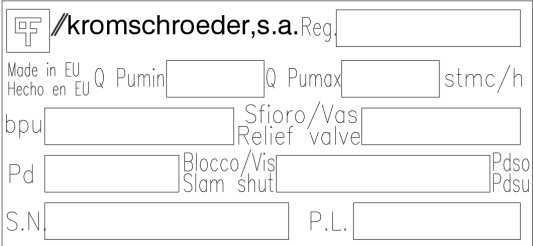
Id.	Type	Image
6	LABEL FOR TURKEY	
7	LABEL EXTENDED TEMPERATURE VERSION	
8	LABEL FOR ROMANIA	
9	LABEL FOR SPAIN KROMS	

Tab. 2.5.

2.8.1 - GLOSSARY FOR NAMEPLATES

The terms and abbreviations used on nameplates are described in Tab. 2.7.:

Description	Label terms					
	Standard	Russia	Poland	Turkey	Romania	Spain Kroms
Inlet pressure range	bpu	<i>bpu</i>	Pe	Pg max/min	-	bpu
Adjusted pressure	pds	<i>Pd</i>	Pa	Pç	-	Pd
Tripping pressure maximum pressure slam-shut device	Slam-shut device VIS Slam Shut pdsu	ЛЗК Макс Pdso	Zaw.up.	EBÜ	-	Slam-shut device VIS Slam Shut Pdso Pdsu
Tripping pressure minimum pressure slam-shut device	Slam-shut device VIS Slam Shut pdsu	ЛЗК МИН Pdsu	Zaw.szy- bkz.	EBA	-	Slam-shut device VIS Slam Shut Pdso Pdsu
Minimum nominal flow rate	Q pumin	-	-	Q min/max	-	Q Pumin
Maximum nominal flow rate	Q pumax	-	Q max	Q min/max	-	Q Pumax
Regulator model	Reg.	<i>per.</i>	Type	-	FE	Reg.
Regulator production lot	P.L.	ДАТА	P.L.	Data + barcode	Year	P.L.
Regulator serial number	S.N.	С.н.	No.	barcode	-	S.N.
Regulator nominal flow rate	-	<i>Nom Q</i>	-	-	-	-
Inlet connections	-	-	DNe	-	DN / Connection	-
Outlet connection	-	-	DNa	-	DN / Connection	-
Operating temperature range	-	-	T3	-	T	-
Accuracy class	-	-	-	ÇT	-	-
Shut-off class	-	-	-	KT	-	-
Maximum pressure slam-shut device Accuracy Group	-	-	-	ETA	-	-
Minimum pressure slam-shut device Accuracy Group	-	-	-	ETÜ	-	-
Regulator head range	-	-	-	As	-	-
Calibration spring range	-	-	-	-	Wds	-
Maximum pressure slam-shut device spring range	-	-	-	EBÜ	-	-
Minimum pressure slam-shut device spring range	-	-	-	EBA	-	-
Design pressure	-	-	-	-	PS	-
Type of fluid	N.G.	-	-	-	Fluid	-
Relief calibration	-	-	-	-	-	Relief VAS Relief Valve

Tab. 2.6.

2.9 - GLOSSARY OF MEASUREMENT UNITS

Type of measurement	Unit of measurement	Description
Volumetric flow rate	Sm ³ /h	Standard cubic metres per hour
	Scfh	Standard cubic feet per hour
Pressure	bar	Unit of measurement in the CGS system
	psi	Pounds per square inch
	"wc	Water column inch
	Pa	Pascal
Temperature	°C	Degree centigrade
	°F	Fahrenheit degree
	K	Kelvin
Tightening torque	Nm	Newton-metre
	ft-lbs	Foot per pound
Sound pressure	dB	Decibel
Other measures	V	Volt
	W	Watt
	Ω	Ohm

Tab. 2.7.

2.10 - QUALIFIED PROFESSIONAL FIGURES

Qualified operators in charge of using and managing the equipment throughout its technical service life:

Professional figure	Definition
Installer	<p>Qualified operator able to:</p> <ul style="list-style-type: none"> • handle materials and equipment. • carry out all the operations necessary to properly install the equipment; • perform all the operations necessary to safely operate the equipment and system; • be able to perform all the operations necessary to uninstall and subsequently dispose of the equipment in compliance with the regulations in force in the country of installation. <p>The installer is not authorised to use the lifting equipment. The equipment must be lifted and handled strictly in accordance with the instructions provided by the manufacturer and the regulations in force at the place where the equipment is installed.</p>
Technical commissioning	<p>Technician trained and authorised to use and manage the equipment for the activities it was supplied for. They must:</p> <ul style="list-style-type: none"> • be able to perform all operations required to properly run the equipment and the system, ensuring their own safety and that of any personnel on site; • access all device parts for visual inspection, equipment checks, adjustments and calibrations. • have proven experience in properly using the equipment similar to that described in this instruction manual, and be trained, informed and instructed in this regard. <p>The skilled technician is not authorised to use the lifting equipment.</p>

Tab. 2.8.

3 - SAFETY

3.1 - GENERAL SAFETY WARNINGS

WARNING!

The equipment described in this instruction manual is:

- a device subjected to pressure in pressurised systems;
- normally installed in systems carrying flammable gases (for example: natural gas).

WARNING!

If the gas used is a combustible gas, the installation area of the equipment is defined as a “danger zone” as there are residual risks that potentially explosive atmospheres may be generated.

In “danger zones” and in close proximity thereto:

- there must not be any effective sources of ignition;
- smoking is not allowed.

ATTENTION!

Authorised operators must not carry out operations or services on their own initiative that do not fall within their competence.

Never operate the equipment:

- while under the influence of intoxicating substances such as alcohol;
- if you are using drugs that may slow reaction times.

NOTICE!

The employer must train and inform operators on how to behave during operations and on the equipment to be used.







Before installation, commissioning or maintenance, operators must:

- take note of the safety regulations applicable to the place of installation they are working in;
- obtain the necessary permits to operate when required;
- wear the personal protective equipment required by the procedures described in this instruction manual;
- ensure that the required collective protective equipment and safety information are available in the area they are operating in.

3.2 - PERSONAL PROTECTIVE EQUIPMENT

Table 3.9 shows the personal protective equipment (PPE) and its description. An obligation is associated with each symbol. Personal protective equipment means any equipment intended to be worn by the worker in order to protect them against one or several risks that are likely to threaten their safety or health during work.

For the operators in charge, depending on the type of work requested, the most appropriate PPE of the following will be reported and must be used:

Symbol	Meaning
	Obligation to use safety or insulated gloves. Indicates a requirement for the personnel to use safety or insulated gloves.
	Obligation to use safety goggles. Indicates a requirement for personnel to use protective goggles for eye protection.
	Obligation to use safety shoes. Indicates a requirement for the personnel to use accident-prevention safety shoes.
	Obligation to use noise protection equipment. Indicates a requirement for the personnel to use ear muffs or ear plugs to protect their hearing.
	Obligation to wear protective clothing. Indicates a requirement for the personnel to wear specific protective clothing.
	Obligation to use a protective mask. Indicates a requirement for the personnel to use respiratory masks in the event of a chemical risk.
	Obligation to use a protective helmet. Indicates a requirement for the personnel to use protective helmets.
	Obligation to wear high visibility vests. Indicates a requirement for the personnel to use high visibility vests.

Tab. 3.9.

WARNING!

Each licensed operator is obliged to:

- **take care of his/her own health and safety and that of other people in the workplace who are affected by his/her actions or omissions, in accordance with the training, instructions and equipment provided by the employer;**
- **appropriately use the PPE made available;**
- **immediately report to the employer, the manager or the person in charge any deficiencies in the equipment and devices, as well as any dangerous conditions they may become aware of.**

3.3 - RESIDUAL RISKS

 **NOTICE!**

The equipment of FEX SERIES does not fall within the scope of the PED 2014/68/EU directive.

The risks associated with the equipment are assessed below and the principles adopted for their prevention are indicated, according to the following classification:

- a) Elimination and/or reduction of the risk.
- b) Application of appropriate protective measures.
- c) information to users about residual risks.

3.3.1 - TABLE SHOWING RESIDUAL RISKS DUE TO PRESSURE

 **WARNING!**

If there are any functional faults, do not operate. Immediately contact PIETRO FIORENTINI S.p.A. for the necessary directions.

Risk and Hazard	Event and Cause	Effect and Consequence	Solution and Prevention
Pressurised gas leakage. Projection of metallic and non-metallic pressurised parts.	<ul style="list-style-type: none"> Violent impact. Impact (also due to falling, improper handling, etc.). 	<ul style="list-style-type: none"> Deformation. Broken connections and, if pressurised, even burst. 	<ul style="list-style-type: none"> a. Handling and installation with appropriate devices to avoid localised stress. b. Installation in suitable places and spaces with appropriate guards and packaging. c. Information/directions contained in this manual.
Pressurised gas leakage. Projection of metallic and non-metallic pressurised parts.	<ul style="list-style-type: none"> Use of inappropriate fluids. 	<ul style="list-style-type: none"> Corrosion. Embrittlement. Explosion. 	<ul style="list-style-type: none"> a. The user must check compliance of the used fluid with what is indicated on the installation sheet.
Pressurised gas leakage. Projection of metallic and non-metallic pressurised parts.	<ul style="list-style-type: none"> Operation at temperatures below the minimum permissible temperature. 	<ul style="list-style-type: none"> Embrittlement. Breakage. Explosion. 	<ul style="list-style-type: none"> a. Install in places where the temperature is not below the minimum permissible value and/or insulate the equipment adequately. b. The minimum allowable temperature is specified in this manual (refer to paragraph 4.5).
Pressurised gas leakage. Projection of metallic and non-metallic pressurised parts. Explosion.	<ul style="list-style-type: none"> Overpressure or exceedance of the rated limit values (maximum pressure allowed). 	<ul style="list-style-type: none"> Explosion. Breaks. Cracks. Permanent deformations. 	<ul style="list-style-type: none"> a. The device has appropriate design safety margins. b. The user must check the maximum pressure applicable to the equipment. c. The design pressure is specified in this manual (refer to paragraph 4.5).
Pressurised fluid leakage. Projection of metallic and non-metallic pressurised parts.	<ul style="list-style-type: none"> Incorrect fixing of the equipment. 	<ul style="list-style-type: none"> Deformation. Breakage. 	<ul style="list-style-type: none"> a. The device is equipped with unified type process connections and compression fittings. b. The installer must ensure correct fixing to the line. c. Information/directions contained in this manual.
Explosion of the device, pressurised fluid leakage. Projection of metallic parts.	<ul style="list-style-type: none"> Operation at temperatures above the maximum permissible temperature. 	<ul style="list-style-type: none"> Reduction of mechanical resistance, breakage of the device. Explosion. 	<ul style="list-style-type: none"> a. The commissioning technician must equip the system with suitable control and safety devices. b. The maximum allowable temperature is specified in this manual (refer to paragraph 4.5).
Pressurised gas leakage. Projection of metallic and non-metallic pressurised parts.	<ul style="list-style-type: none"> Electrostatic potential differential stray currents. 	<ul style="list-style-type: none"> Corrosion localised in the device. 	<ul style="list-style-type: none"> a. The commissioning technician must check the equipment for proper earthing.

Risk and Hazard	Event and Cause	Effect and Consequence	Solution and Prevention
Pressurised gas leakage. Projection of metallic and non-metallic pressurised parts.	<ul style="list-style-type: none"> • Humidity. • Environments with aggressive atmosphere. 	<ul style="list-style-type: none"> • Deterioration of external surfaces. • corrosion. 	a. The user must shut off the line and contact PIETRO FIORENTINI S.p.A.

Tab. 3.10.

3.3.2 - TABLE OF RESIDUAL RISKS FOR POTENTIALLY EXPLOSIVE ATMOSPHERES

Table 3.11 shows the conditions that can lead the pressure regulators FEX SERIES to generate a potentially explosive atmosphere.

The table is valid for use with natural gas with a density of no more than 0.8; for different densities, the installation and environmental conditions must also be evaluated.

⚠ WARNING!

If the gas used is a combustible gas, the area where the equipment is installed is defined as a “hazardous area”, because there are residual risks associated with the formation of potentially explosive atmospheres, where no effective ignition sources must be present.

Operating conditions	Atmosphere potentially explosive	Regulatory References	Management measures included in the use, maintenance and warning manual
First start-up	No	<ul style="list-style-type: none"> During the production cycle, the external sealing of the equipment is checked according to the UNI 11655:2016 standard. Before commissioning, the external sealing of the system portion on which the equipment is installed is checked according to the requirements applicable in the place of installation (when installed in pressure reduction systems, the provisions of 12186:2014 and UNI EN12279:2007 must be adhered to). 	The manual refers to the need to check the external sealing and, when applicable, meet the requirements of the UNI EN 12186:2014 and UNI EN 12279: 2007 standards.
Operation in normal conditions	No	<p>The provisions in the previous point apply and, in addition:</p> <ul style="list-style-type: none"> the equipment is installed outdoors or in an environment with natural ventilation according to the regulations in force in the place of installation, or, when applicable, standards EN 12186:2014 and EN 12279:2007; is monitored according to the national rules in force, good practice and the instructions of the equipment manufacturer. 	<p>The manual reports that:</p> <ul style="list-style-type: none"> any room that the equipment is installed in must meet the ventilation requirement for the place of installation, or, when applicable, the provisions in standards EN 12186:2014 and EN 12279:2007; periodic checks must be carried out during surveillance in accordance with the national rules in force, if any, and with the specific manufacturer's recommendations.
Breakage of diaphragms	No	This event must be considered a rare malfunction.	The manual refers to the need to meet the periodic check requirements in accordance with the regulations in force in the place of installation.

Operating conditions	Atmosphere potentially explosive	Regulatory References	Management measures included in the use, maintenance and warning manual
Breakage of other non-metallic parts (malfunction)	No	This type of malfunction is not reasonably expected as it involves static seals (to the outside) that cannot generate any external leakage.	-
Decommissioning	No	<ul style="list-style-type: none"> • Pressure must be reduced in the system section, where the equipment is installed, inside a suitably ventilated room. • The residual gas must be discharged as indicated above. 	The manual refers to the need to operate in a suitably ventilated environment.
Reboot	No	<ul style="list-style-type: none"> • After reassembling the regulator, carry out an external leakage test at a suitable pressure value, as specified by the Manufacturer. • Before commissioning, the external sealing of the system portion on which the equipment is installed is checked according to the requirements applicable in the place of installation (when installed in pressure reduction systems, the provisions of 12186:2014 and UNI EN12279:2007 must be adhered to). 	The following is referred to in the manual: <ul style="list-style-type: none"> • the minimum conditions for testing the equipment for external leakage; • the need to check external sealing and, when applicable, meet the requirements of the UNI EN 12186:2014 and UNI EN 12279: 2007 standards.

Tab. 3.11.

3.4 - OBLIGATIONS AND PROHIBITIONS

The following is a list of obligations and prohibitions to be observed for the safety of the operator:



- carefully read and understand the use, maintenance and warning manual;
- check whether the downstream equipment is suitably sized according to the performance required of the regulator in the actual operating condition;
- before installing the equipment, strictly refer to the details specified on the nameplates and in the manual;
- Avoid violent shocks and impacts that could damage the equipment and, as a result, cause the pressure fluid to escape.

It is strictly forbidden to:

- operate in various capacities on the equipment without the PPE indicated in the work procedures described in this manual;
- operate in the presence of open flames or bring open flames close to the work area;
- smoke near the equipment or while working on it;
- use the equipment with parameters other than those indicated on the nameplate;
- use the equipment with fluids other than those indicated in this manual;
- use the equipment outside the operating temperature range specified in this manual;
- install or use the equipment in environments other than those specified in this manual.

3.5 - SAFETY PICTOGRAMS

The following safety pictograms may be shown on the equipment and/or packaging PIETRO FIORENTINI S.p.A.:

Symbol	Definition
	Symbol used to identify an ELECTRICAL HAZARD.
	Symbol used to identify a GENERIC HAZARD.

Tab. 3.12.

 **HAZARD!**

It is absolutely forbidden to remove the safety pictograms on the equipment. The user is required to replace the safety pictograms which, following wear, removal or tampering, are illegible.

3.6 - RISK LEVEL

Depending on the operating conditions, use and configuration required, the equipment may generate noise beyond the limits allowed by current legislation in the country of installation. For the value of the noise generated by the equipment and further information, contact PIETRO FIORENTINI S.p.A.

 **ATTENTION!**

The obligation to use headphones or ear plugs to protect the operator's hearing remains in the event that the noise in the installation environment of the equipment (depending on specific operating conditions) exceeds the value of 85 dBA.

PAGE INTENTIONALLY LEFT BLANK

4 - DESCRIZIONE E FUNZIONAMENTO

4.1 - GENERAL DESCRIPTION

The equipment is a self-operated dual-stage low-pressure regulator suitable for gaseous fluids such as:

- natural gas;
- GPL;
- non-corrosive gases.

The main elements of the equipment are specified in Tab. 4.13.:

Pos.	Descrizione	Pos.	Descrizione
1	Inlet connections (in-line)	6	Outlet connections: a: in-line b: in a square pattern
2	First stage regulation	7	Slam-shut valve for minimum and maximum downstream pressure
3	Double stage regulation	8	Relief valve
4	Slam-shut valve reset knob for minimum maximum downstream pressure	9	Valve of second stage regulation (3)
5	Reset knob protection cap (4)	-	-

Tab. 4.1.

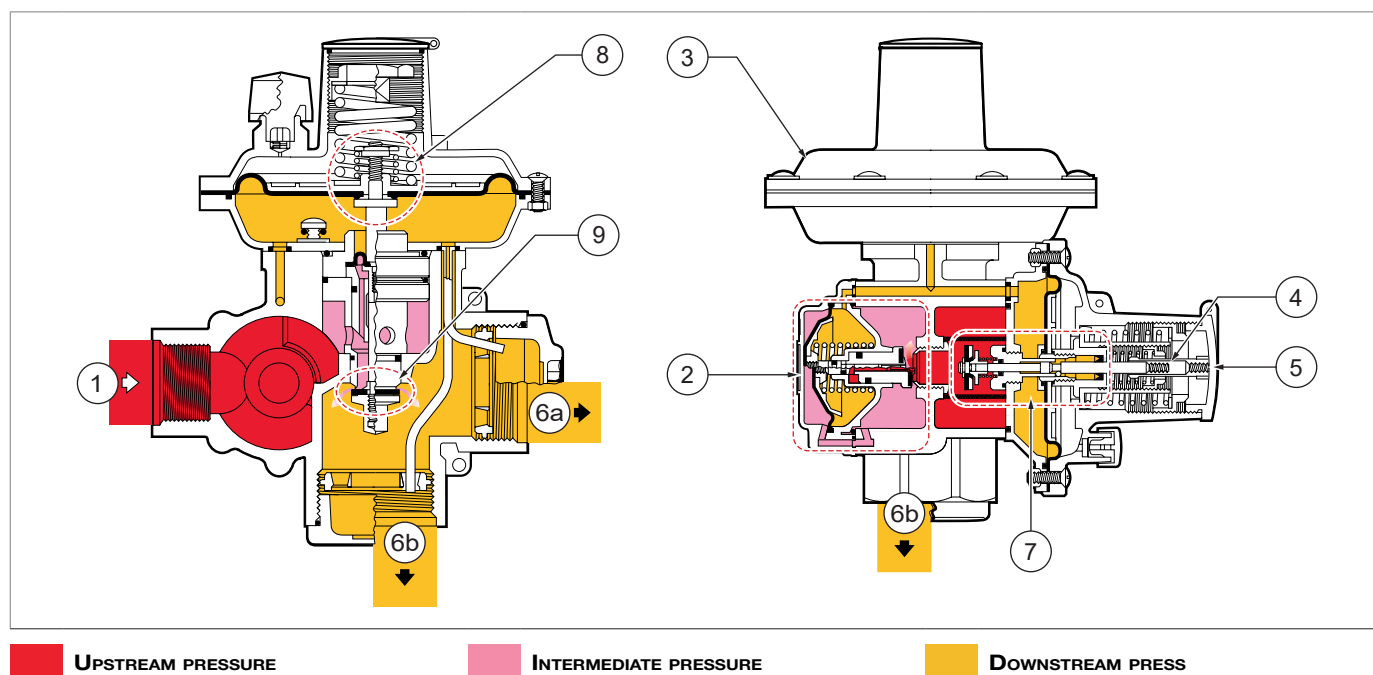

Fig. 4.1. General description FEX SERIES (basic version)

4.2 - OPERATION

FEX SERIES equipment consists of regulators featuring:

- self-operation;
- low pressure suitability;
- a dual regulation stage.

Tab. 4.14. describes the operation of the equipment in a simplified manner:

Step	Description
1	The upstream pressure (A) feeds the regulator.
2	The first regulation stage (B) determines the first pressure reduction.
3	Intermediate pressure is adjusted by the second regulation stage (C) to the value of the downstream pressure (D) required by the user.
4	In the event of faults, the safety devices will trip: <ul style="list-style-type: none"> • relief valve (E); • slam-shut valve for minimum and maximum downstream pressure (F).

Tab. 4.2.

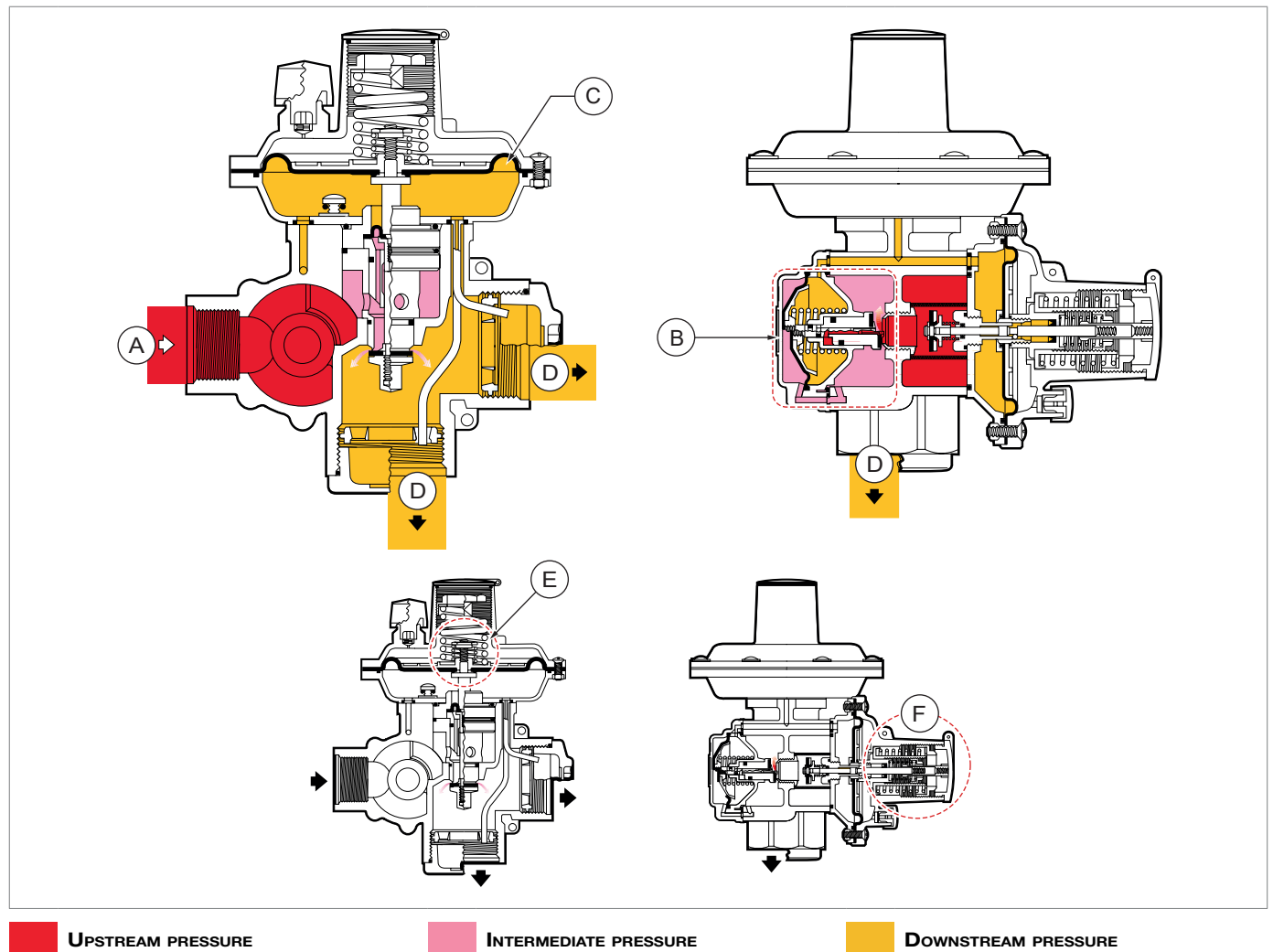

Fig. 4.2. Operation FEX SERIES

4.3 - INTENDED USE

4.3.1 - ENVISAGED USE

NOTICE!

The equipment of FEX SERIES is used to adjust the pressure to a pre-set value. It can be installed directly on:

- user's gas meters.
- rising pillars;
- burners.

The equipment in question is intended for:

Operation	Permitted	Unpermitted	Work environment
Adjustment of the downstream pressure for:	Gaseous, and non-aggressive or corrosive fluids filtered beforehand.	<ul style="list-style-type: none"> • Liquids. • Any product other than those permitted. 	Installations for the distribution of natural gas to supply networks for: <ul style="list-style-type: none"> • commercial use; • home use.

Tab. 4.3.

The equipment referred to was designed to be used exclusively within the limits specified on the nameplate and according to the instructions and limits of use specified in this manual.

Safe work conditions are as follows:

- use within the limits stated on the nameplate and in this manual;
- compliance with the operating and warning instructions as well as commissioning procedures (refer to chapter 8);
- do not tamper with and/or bypass the safety devices.

4.3.2 - REASONABLY FORESEEABLE MISUSE

Incorrect and reasonably foreseeable use means the use of the equipment in a way not foreseen in the phase but which can derive from easily predictable human behaviour:

- corrosive fluids;
- fluids not properly treated upstream;
- liquids;
- instinctive reaction of an operator in the event of a malfunction, accident or breakdown while using the equipment;
- behaviour resulting from pressure to keep the equipment running under all circumstances;
- behaviour resulting from carelessness;
- behaviour resulting from the use of the equipment by unauthorised and unsuitable people (children, disabled);
- using the equipment in a manner other than that referred to under "Intended use".

Any use of the equipment other than the intended use must be previously approved in writing by PIETRO FIORENTINI S.p.A. If no written approval is provided, use shall be considered improper.

In the event of "improper use", PIETRO FIORENTINI S.p.A. shall not be held liable for any damage caused to people or property, and any type of warranty on the equipment shall be deemed void.

4.3.3 - TYPES OF FLUIDS

The equipment works with combustible gases used:

- in pressure control stations according to UNI EN 12186:2014 and UNI EN 12279:2007 standards, or in installations carrying LPG;
- in commercial premises and industrial plants (after checking by contacting PIETRO FIORENTINI S.p.A.).

NOTICE!

The equipment may be also used with inert gases, subject to verification by contacting the manufacturer.

4.4 - MODELS AND CONFIGURATIONS

FEX SERIES provides 3 standard models based on the nominal flow rate as specified in Tab. 4.16.:

Regulator trade name	Nominal flow rate	Minimum input pressure
FEX50	50 m ³ /h	pds + 0,5 bar
FEX75	75 m ³ /h	pds + 0,5 bar
FEX100	100 m ³ /h	pds + 0,5 bar

Tab. 4.4.

Various configurations can be set up based on inlet/outlet connections:

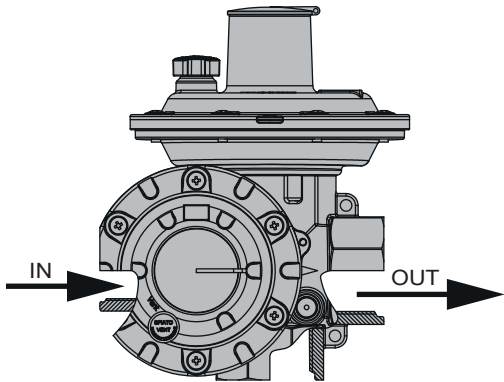
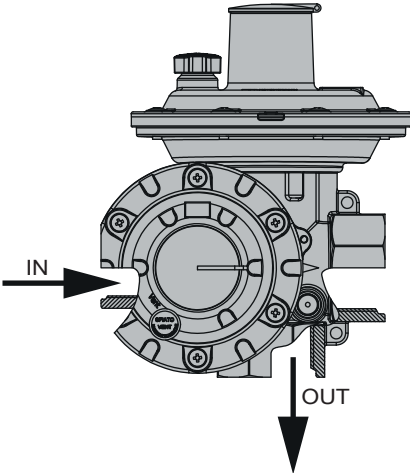
Type	Inlet connection (modular connections on request)	Outlet connection (modular connections on request)	Image
FEX L	n°1 G 1" EN ISO 228/1	n°1 G 1" ½ EN ISO 228/1	
FEX S	n°1 G 1" EN ISO 228/1	n°1 G 1" ½ EN ISO 228/1	

Tab. 4.5.

NOTICE!

Mounting positions with the outlet connection facing down are recommended in installations using LPG.

Other versions can be set up according to the safety devices installed:

- » slam-shut valve for maximum downstream pressure (always envisaged);
- » minimum downstream pressure shut-off function (optional);
- » relief valve (optional);
- » without lock for minimum and maximum downstream pressure (optional).

Some typical versions are listed below, also by way of example:

Type	Description
Version with safety diaphragm	<p>In case of breakage of the working diaphragm, installing a safety diaphragm guarantees:</p> <ul style="list-style-type: none"> • service continuity; • adjusted pressure control; • the ability to identify the working diaphragm through controlled gas leakage into the atmosphere (< 30 l/h gas).
Version with thermal valve	<p>The thermal valve, built into the inlet fitting, ensures that the power supply to the regulator is cut off when the ambient temperature reaches 160 °C.</p> <div data-bbox="464 741 1469 869" style="border: 1px solid black; padding: 5px;"> <p>! NOTICE! The version with thermal valve requires that specific fittings are requested from the sales offices PIETRO FIORENTINI S.p.A..</p> </div>
Version set up for indoor installation	<p>In the event of complete failure, this version guarantees that gas is dispersed into the atmosphere at a lower than 30 l/h flow rate.</p> <div data-bbox="464 958 1469 1086" style="border: 1px solid black; padding: 5px;"> <p>! NOTICE! Indoor installation is subject to the regulations in force in the country of installation. Regulatory checks are the responsibility of the installer.</p> </div>
Underground version	<p>Special surface guards combined with the use of specific components make this version suitable for installation in underground wells.</p> <div data-bbox="464 1176 1469 1303" style="background-color: yellow; border: 1px solid black; padding: 5px;"> <p>! ATTENTION! The underground version of the regulator is not suitable for operation if completely covered by earth or other types of debris.</p> </div> <div data-bbox="464 1317 1469 1444" style="border: 1px solid black; padding: 5px;"> <p>! NOTICE! For specific installation and checks of the underground version after commissioning, see chapter 7.</p> </div>
Arctic version	<p>This version guarantees correct operation with:</p> <ul style="list-style-type: none"> • ambient temperature: up to -40 °C and/or • gas temperature up to -30 °C. <div data-bbox="464 1570 1469 1697" style="border: 1px solid black; padding: 5px;"> <p>! NOTICE! The low temperature version of the regulator is identified through a specific plate (see paragraph 2.8).</p> </div>

Tab. 4.6.

4.4.1 - SURFACE TREATMENTS

! NOTICE!

Surface treatments (special painting, anticorrosive treatments, galvanising,...) are foreseen for specific needs and/or particular environmental conditions.

4.5 - TECHNICAL FEATURES/PERFORMANCE

! NOTICE!

To classify the functional performance of the equipment, refer to standards UNI 11655:2016 and UNI EN 16129:2013.

The main specifications can be found in Tab.4.19:

Caratteristiche tecniche

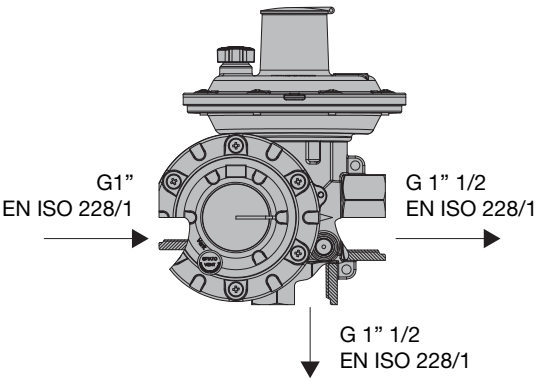
Design pressure (DP)	0.86 MPa 8.6 bar	
Inlet pressure range	0.01 ÷ 0.86 Mbar 0.1 ÷ 8.6 bar	
Regulator capacity	1765 ÷ 3530 ft ³ /h 50 ÷ 100 m ³ /h	
Adjustment range of downstream pressure	BP version: 1.3 ÷ 9.9 kPa 13 ÷ 99 mbar	
	TR version: 10 ÷ 35 kPa 100 ÷ 350 mbar	
Accuracy class (AC)	10	
Lock up over pressure (SG)	20	
Operating ambient temperature	-20 °C + 60 °C (standard version) -30 °C + 60 °C (extended temperature version) * -40 °C + 60 °C (arctic version) *	
Permissible gas temperature	-10 °C + 60 °C (standard version) -20 °C + 60 °C (extended temperature version) * -30 °C + 60 °C (arctic version) *	
Inlet connection	G 1" EN ISO 228/1 (fittings on request)	
Outlet connection	<ul style="list-style-type: none"> In-line outlet: G 1"½ EN ISO 228/1 Outlet in a square pattern: G 1"½ EN ISO 228/1 (fittings on request) 	
Fittings	<ul style="list-style-type: none"> Gas (as per UNI EN ISO 228-1:2003); Flat swivel joint (as per NF E29-533: 2014 and NF E29-536: 2017); NPT (according to ASME B1.20.1, excluding connections with metal/metal sealing); Specials (on request). 	

* Version identified by specific nameplate (refer to paragraph 2.8)

Tab. 4.7.

4.6 - SAFETY DEVICE

To prevent the safety devices from tripping during normal service (when there are no faults at user level):

- do not exceed the maximum capacity values of the regulator;
- do not feed the regulator with pressures lower than the minimum values specified;
- do not purge of the downstream line with the regulator installed.

4.6.1 - SLAM-SHUT VALVE FOR MINIMUM AND MAXIMUM DOWNSTREAM PRESSURE

NOTICE!

If the valve trips, service will be interrupted.

The slam-shut valve for minimum and maximum downstream pressure (A) is a safety device that remains open in normal service conditions and automatically and completely closes the gas flow when the maximum downstream pressure exceeds the calibration values.

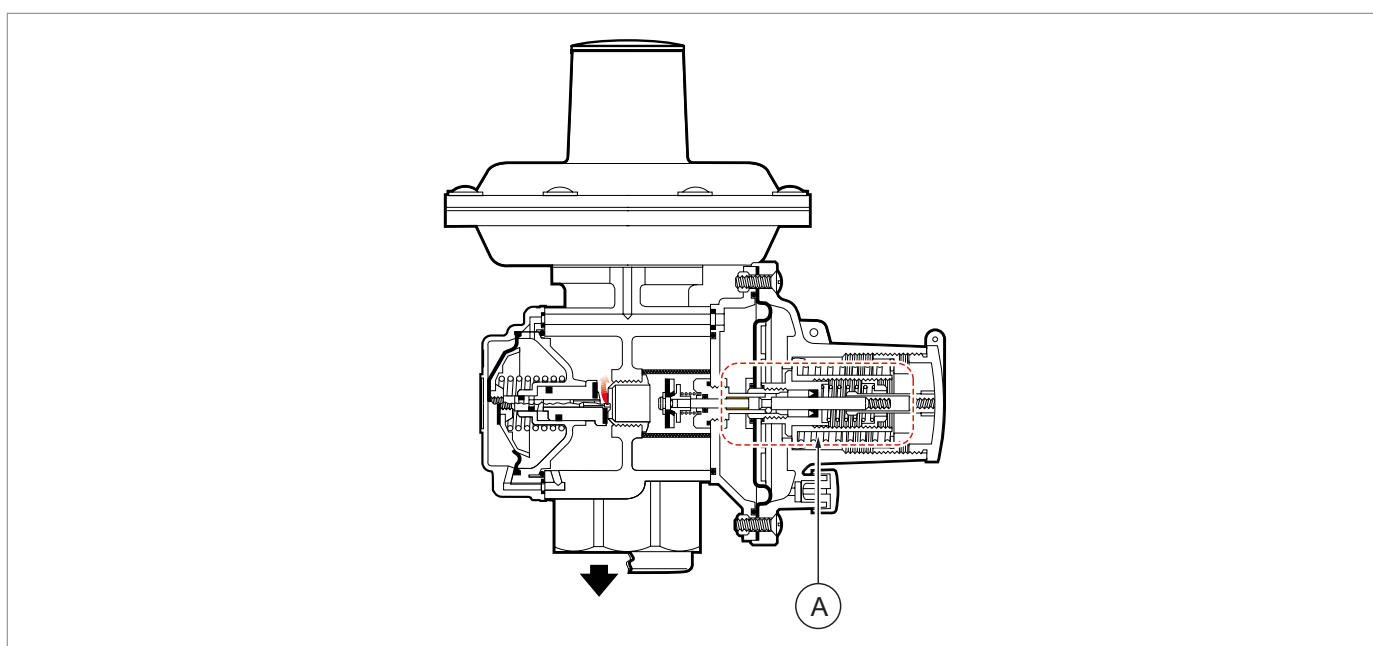

Fig. 4.3. Slam-shut valve for minimum and maximum pressure

4.6.2 - RELIEF VALVE

The relief valve (A) is a safety device that is used to:

- automatically discharge a gas flow into the atmosphere through the exhaust conveyor (B), when the pressure detected downstream exceeds a pre-set value and
- to automatically return to closed position when the downstream pressure drops below the opening/discharge value.

The relief valve trips due to:

- thermal expansion of the downstream gas with no flow;
- temporary defective sealing of the plugs in the first and second regulation stages.

NOTICE!

The tripping pressure value of the relief valve is lower than the tripping pressure value of the slam-shut valve for maximum downstream pressure.

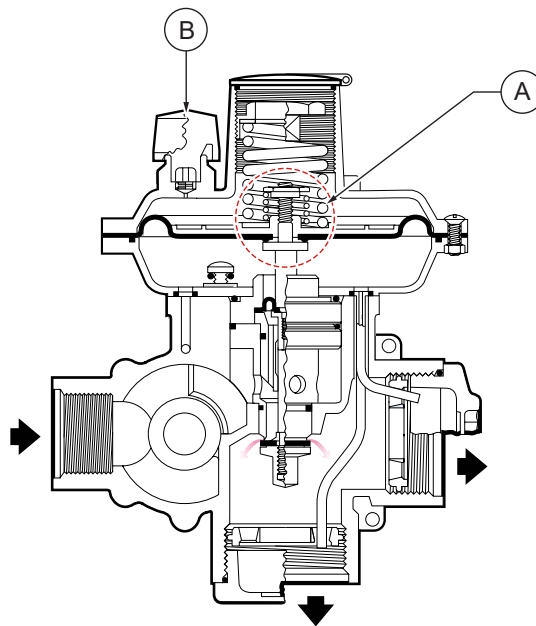

Fig. 4.4. Relief valve

4.6.3 - PRESSURE OUTLET

NOTICE!

For an in-field check of the safety devices, a pressure outlet (A) built in the regulator or on the downstream section of the system is required.

Only two types of pressure outlet can be built into the regulator:

- standard (A);
- Peterson model (B).

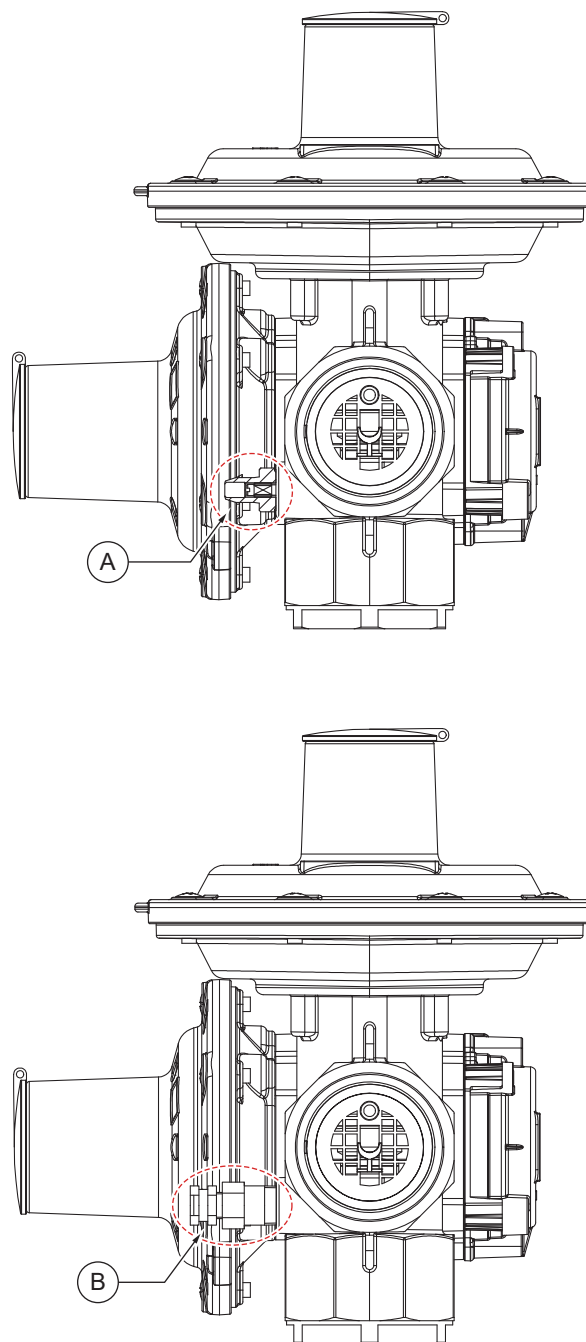

Fig. 4.5. Pressure outlet

4.6.3.1 - PROCEDURE OF USE WITH STANDARD PRESSURE OUTLET

ATTENTION!

The maximum operating pressure for the standard pressure outlet is 0.5 bar.

To use a standard pressure outlet (A), proceed as in Tab.:

Step	Action
1	Undo the locking screw (B).
2	Fit the rubber tube on the tang (C) making sure that the connection is sealed.
3	Tighten the locking screw (B) making sure there are no leaks from the pressure outlet.

Tab. 4.8.

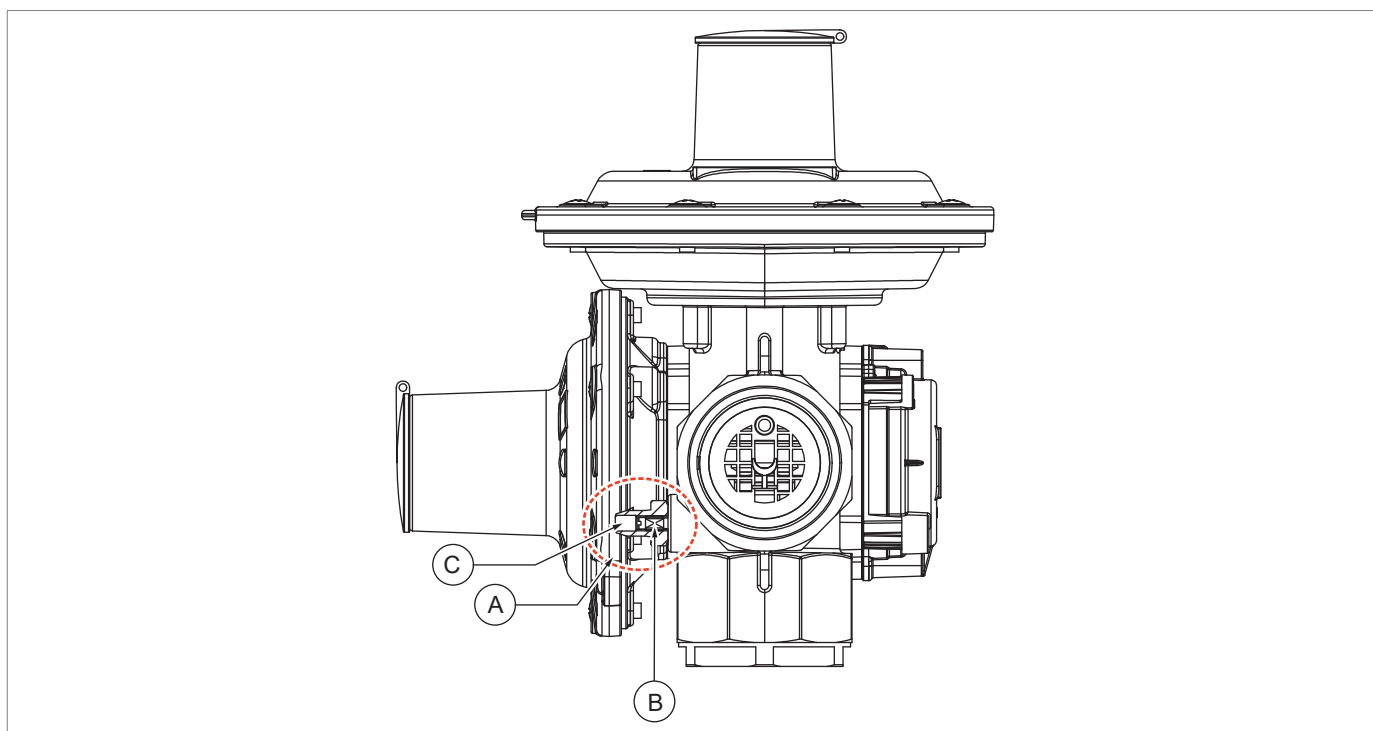

Fig. 4.6. Standard pressure outlet use

4.6.3.2 - PROCEDURE OF USE WITH PETERSON MODEL PRESSURE OUTLET

⚠ ATTENTION!

The maximum operating pressure for a Peterson model standard pressure outlet is 10 bar.

! NOTICE!

The pressure gauge (E) and the ring nut (D) are not included in the standard scope of supply and are supplied only on request.

To use a Peterson model pressure outlet (A), proceed as in Tab.4.9:

Step	Action
1	Remove the closing cap (B).
2	Fit the pin (C) until the connection with the gas chamber of the outlet body is made, then lock it through the ring nut (D). ! NOTICE! The pin (C) is not present on the regulator but is an accessory of the pressure outlet.
3	Read the pressure measured on the pressure gauge (E).
4	After reading, loosen the ring nut (D) to unlock the pin (C).
5	Remove the pin (C).
6	Put the closing cap (B) back in place.

Tab. 4.9.

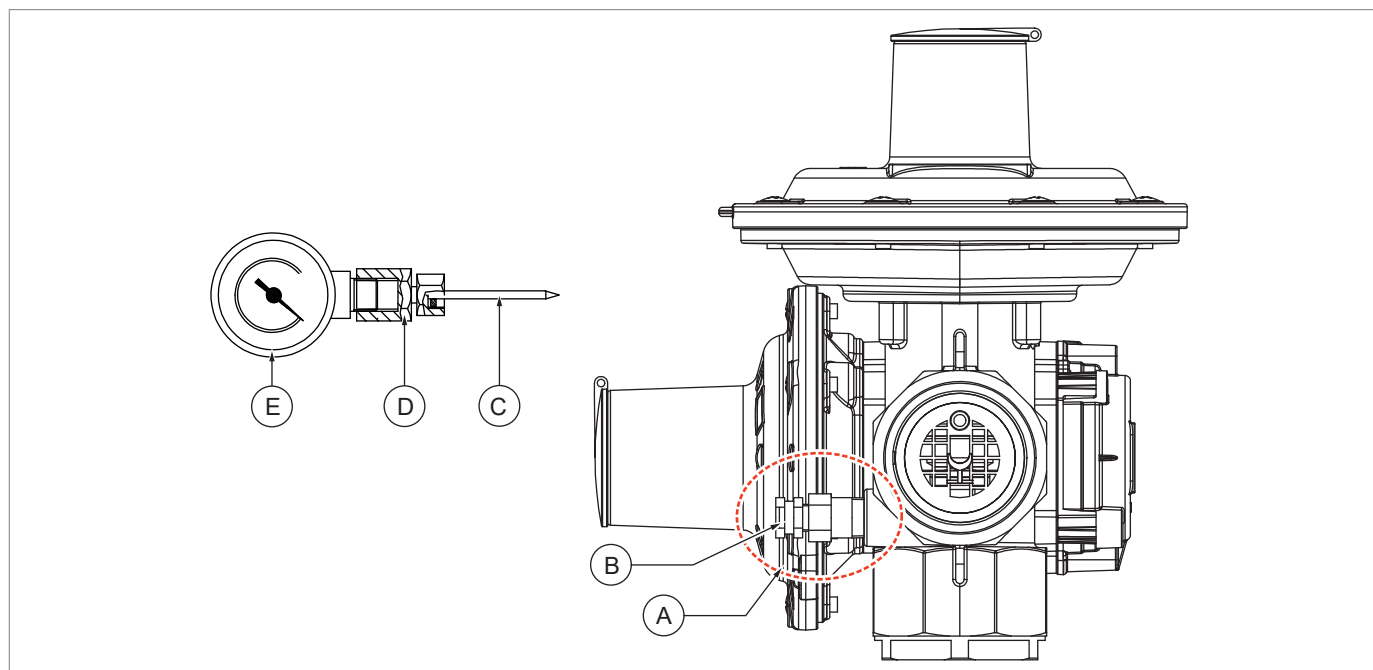

Fig. 4.7. Peterson model pressure outlet use

PAGE INTENTIONALLY LEFT BLANK

5 - TRANSPORT AND HANDLING





5.1 - SPECIFIC WARNINGS FOR TRANSPORT AND HANDLING

NOTICE!

Transport and handling must be carried out in compliance with the regulations in force in the country of installation by personnel who are:

- qualified (specially trained);
- who are familiar with accident prevention and workplace safety regulations;
- authorised to use lifting equipment.

Transport and handling

Operator qualification	<ul style="list-style-type: none"> • Installer.
PPE required	<div style="display: flex; align-items: center;">     </div> <div style="background-color: #f4a460; padding: 5px; margin-top: 5px;">  WARNING! </div> <p>The PPE listed in this table is related to the risk associated with the equipment. For the PPE required to protect against risks associated with the workplace, installation or operating conditions, please refer to:</p> <ul style="list-style-type: none"> • the regulations in force in the country of installation; • <u>any information provided by the Safety Manager at the installation facility.</u>
Weights and dimensions of the equipment	For dimensions and weights, refer to paragraph 5.2 "Physical characteristics of the equipment".

Tab. 5.10.

5.1.1 - PACKAGING AND FASTENERS USED FOR TRANSPORT

The transport packaging is designed and manufactured to avoid damage during normal transport, storage and handling. The equipment must be kept in the packaging until installation.

Upon receiving the equipment, please:

- make sure that no part has been damaged during transport and/or handling;
- immediately report any damage found to PIETRO FIORENTINI S.p.A..

NOTICE!

PIETRO FIORENTINI S.p.A. shall not be liable for any damage to people or property caused by accidents due to failure to comply with the instructions provided in this manual.

Tab. 5.23. describes the types of packaging used:

Ref.	Type of packaging	Image
A	Single cardboard box	

Tab. 5.11.

5.2 - STANDARD FEX PHYSICAL CHARACTERISTICS

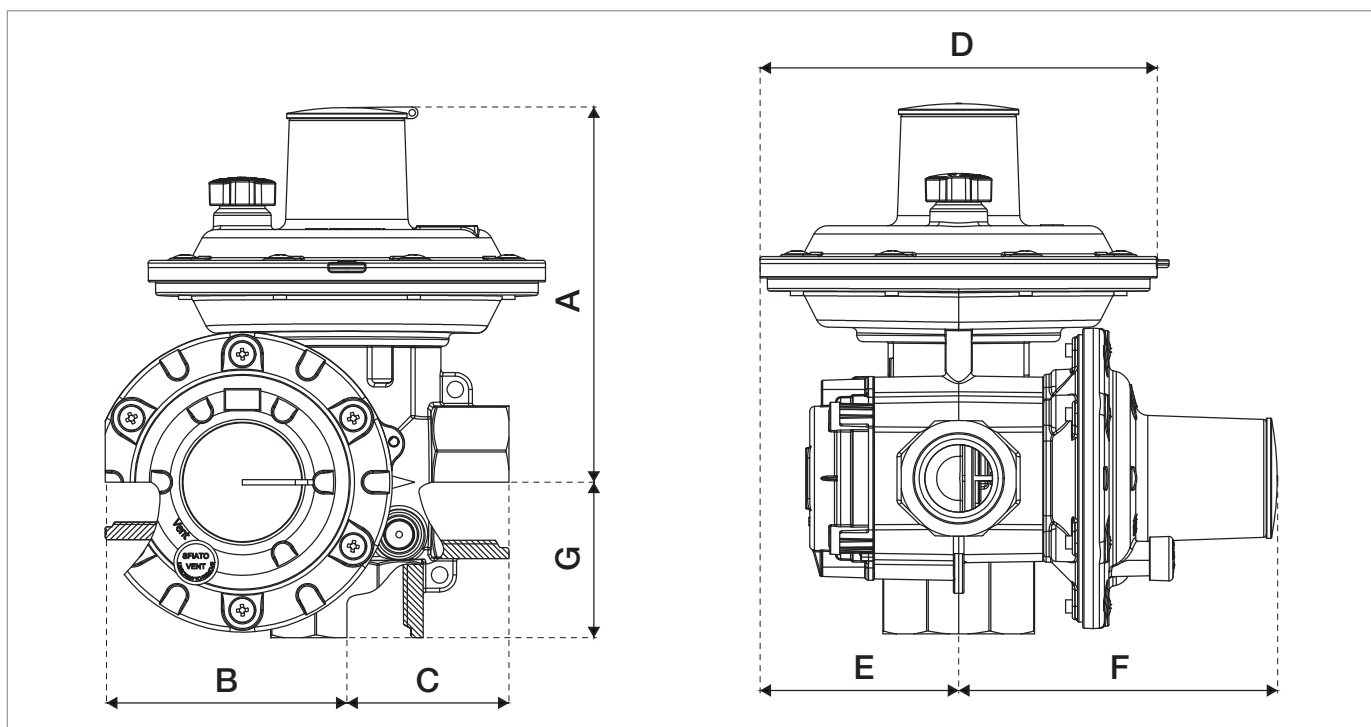

Fig. 5.8. Physical characteristics FEX SERIES standard

Overall dimensions	
Ref.	Dimensions [mm]
A	144
B	92
C	62
D	Ø152
E	76
F	122
G	60

Tab. 5.12.

Weights [kg]	
Aluminium regulator (with slam-shut valve)	2.1
Minimum increase with 3/4 SC x 1"1/4 GP fittings	0.15
Maximum increase with DN50 flange	2.3

Tab. 5.13.

NOTICE!

See the product configurator ('sizing') at PIETRO FIORENTINI S.p.A. (www.fiorentini.com) for equipment dimensions and weights.

5.2.1 - PHYSICAL CHARACTERISTICS FEX WITHOUT SLAM-SHUT VALVE

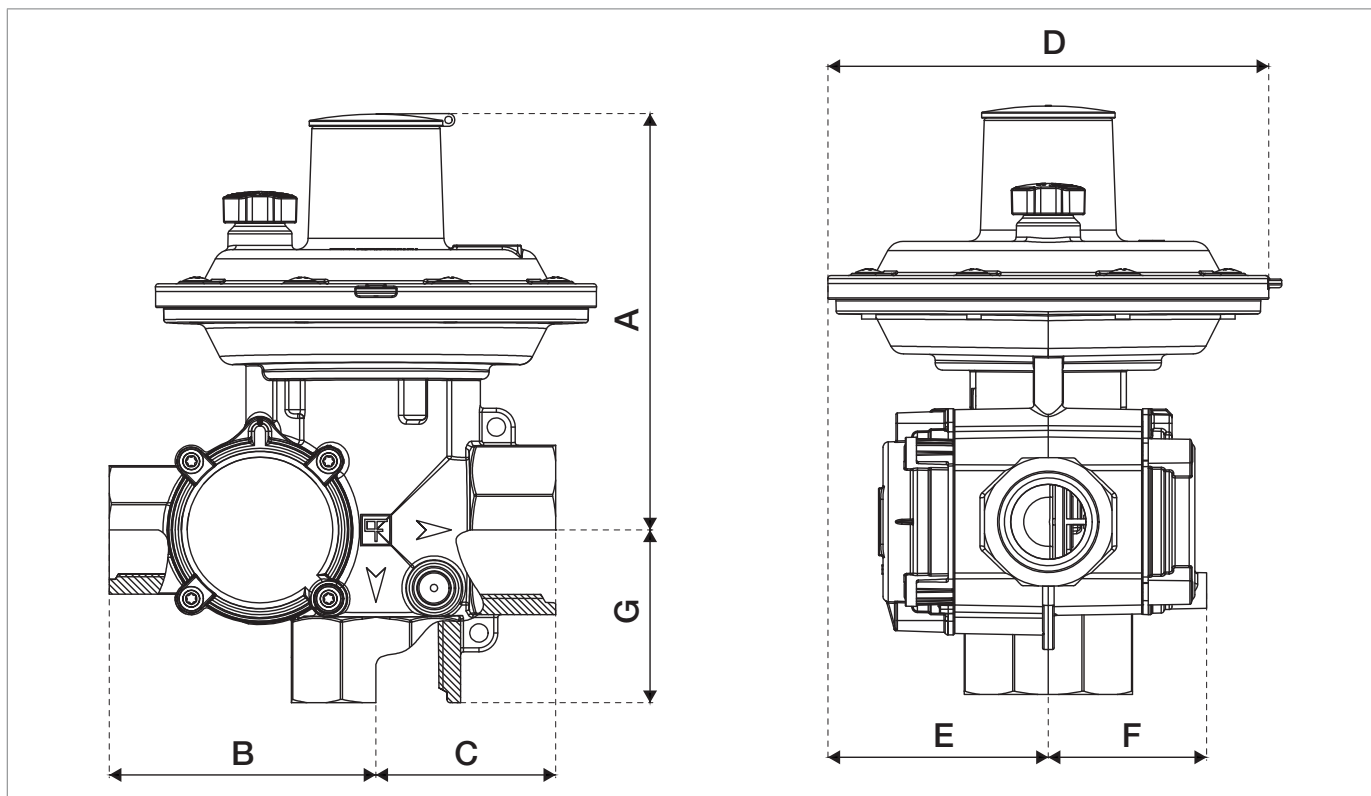

Fig. 5.9. Physical characteristics FEX SERIES without slam-shut device

Overall dimensions	
Ref.	Dimensions [mm]
A	144
B	92
C	62
D	Ø152
E	76
F	55
G	60

Tab. 5.14.

Weights [kg]	
Aluminium regulator (without slam-shut valve)	1.6
Minimum increase with 3/4 SC x 1"1/4 GP fittings	0.15
Maximum increase with DN50 flange	2.3

Tab. 5.15.

NOTICE!

See the product configurator ('sizing') at PIETRO FIORENTINI S.p.A. (www.fiorentini.com) for equipment dimensions and weights.

5.3 - EQUIPMENT ANCHORING AND LIFTING METHOD

HAZARD!

Using lifting equipment (if necessary) for unloading, carrying and handling packages is reserved only for skilled operators who have been properly trained (and are appropriately qualified if required by the regulations in force in the country of installation) and are familiar with:

- accident prevention rules;
- workplace safety provisions;
- lifting equipment features and limits.

HAZARD!

Before handling a load, make sure that its weight does not exceed the load capacity of the lifting equipment (and any other lifting tools) specified on the specific plate.

ATTENTION!

Before moving the equipment:

- remove any movable or hanging component or firmly secure it to the load;
- protect fragile equipment;
- check that the load is stable;
- make sure to have perfect visibility along the route.

5.3.1 - FORKLIFT HANDLING METHOD

HAZARD!

It is forbidden to:





- Do not transit under suspended loads;
- Do not move the load over the personnel operating in the site/plant area.

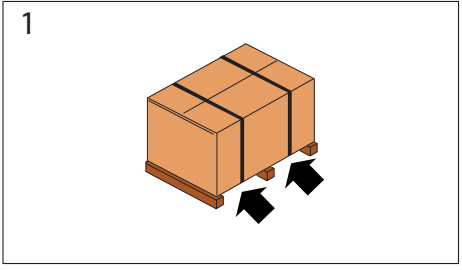

WARNING!

The following is not allowed on forklifts:

- carrying passengers;
- lifting people.

If cardboard boxes (single or multiple) are carried on a pallet, proceed as follows:

Step	Action	Image
1	Place the forks of the forklift under the load surface.	
2	Make sure that the forks protrude from the front of the load (by at least 5 cm), far enough to eliminate any risk of the transported load tipping.	
3	Raise the forks until they are touching the load. NOTICE! Fasten the load to the forks with clamps or similar devices if required.	
4	Slowly lift the load by a few dozen centimetres and check its stability, making sure that the centre of gravity of the load is at the centre of the lifting forks.	

Step	Action	Image
5	Tilt the mast backwards (towards the driver's seat) to help the over-turning moment and to ensure greater load stability during transport.	
6	Adjust transport speed according to the type of floor and load, avoiding sudden manoeuvres. <div style="background-color: #f4a460; padding: 5px; margin: 5px 0;">  WARNING! </div> In the case of: <ul style="list-style-type: none"> • obstacles along the path; • particular operating situations hinder operator visibility, the assistance of a ground operator is required, standing outside the range of action of the lifting equipment, with the task of signalling.	-
7	Place the load in the chosen installation area.	-

Tab. 5.16.

5.4 - PACKAGING REMOVAL

Packaging removal	
Operator qualification	<ul style="list-style-type: none"> Installer.
PPE required	 <p>WARNING!</p> <p>The PPE listed in this table is related to the risk associated with the equipment. For the PPE necessary to protect against risks associated with the workplace or operating conditions, please refer to:</p> <ul style="list-style-type: none"> the regulations in force in the country of installation; <u>any information provided by the Safety Manager at the installation facility.</u>

Tab. 5.17.

To unpack the equipment in a cardboard box, proceed as specified in Tab.5.30:

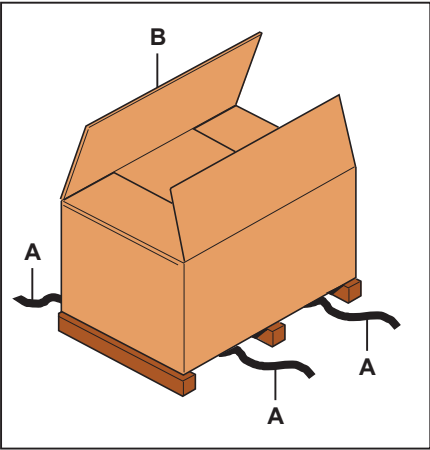
Step	Action	Image
1	Remove the straps (A).	
2	Remove the packaging cardboard (B).	
3	Remove the fasteners that secure the equipment to the base (if any).	
4	<p>Move the equipment from the base to the place intended for it.</p> <p>NOTICE!</p> <p>Have at least 2 operators manually move the packages if required due to their dimensions/weight.</p>	

Tab. 5.18.

NOTICE!

After removing all packaging materials, check for any anomalies.

If there are anomalies:

- do not install the equipment;
- contact PIETRO FIORENTINI S.p.A. and specify the details provided on the equipment nameplate.

5.4.1 - PACKAGING DISPOSAL

NOTICE!

Sort the various materials making up the packaging and dispose of them in compliance with the regulations in force in the country of installation.

5.5 - STORAGE AND ENVIRONMENTAL CONDITIONS

WARNING!

Protect the regulator from blows and impacts, even accidental, until it is installed.

If the equipment needs to be stored for an extended period, the minimum environmental conditions for the intended storage are provided in Tab.5.31. Compliance with these conditions will guarantee the declared performance:

Conditions	Data
Maximum storage period	5 years.
Temperature	Not above 40°C
Humidity	Not above 70%
Radiation and light sources	Away from radiation and light sources according to UNI ISO 2230:2009

Tab. 5.19.

5.5.1 - STORAGE LASTING LONGER THAN THE MAXIMUM TIME ALLOWED

NOTICE!

After a storage period exceeding the maximum time allowed (5 years), the equipment must be scrapped.

PAGE INTENTIONALLY LEFT BLANK

6 - INSTALLATION

6.1 - INSTALLATION PRE-REQUISITES

6.1.1 - ALLOWED ENVIRONMENTAL CONDITIONS

 **WARNING!**

To safely use the equipment, in full respect of the allowed environmental conditions, follow the data shown on the regulator plate and on any accessories (refer to paragraph 2.8 “Nameplates applied”).

The installation site must be suitable for the safe use of the equipment.

The installation area of the equipment must be properly lit to ensure proper operator visibility during working on the equipment.

6.1.2 - STORAGE LASTING LONGER THAN THE MAXIMUM TIME ALLOWED

 **WARNING!**

Installing the equipment after storage exceeding the maximum admissible time (5 years) is not allowed. After a storage period exceeding the maximum time allowed, the equipment must be scrapped.

6.1.3 - CHECKS BEFORE INSTALLATION

With respect to its **design pressure (DP)**, the equipment does not require any further safety device upstream to protect against any overpressure when, for the upstream reduction station, the maximum incidental downstream pressure is:

$$\text{MIPd} \leq 1.1 \text{ DP}$$

MIPd = Maximum incidental downstream pressure value (for further information, see UNI EN 12186:2014).

ATTENTION!

If the installation of the equipment requires the field application of compression fittings, these must be installed in accordance with the instructions of the manufacturer of the fittings themselves.







The choice of fittings must be compatible with:

- the use specified for the equipment;
- the plant specifications when required.

Before installation, it must be ensured that:

- the flow direction is observed as shown on the regulator;
- the data shown on the nameplate matches the requirements of the connected combustion equipment;
- at least one shut-off valve is installed upstream;
- at least one shut-off valve is installed downstream;
- the expected dimensions of the installation site are compatible with those of the equipment;
- the inlet/outlet pipes do not exert loads on the equipment;
- the inlet and outlet connections of the equipment are clean and flawless;
- the inside of the upstream pipe is clean and free of processing residues such as welding slag, sand, paint residues, water, etc....

Installation

Operator qualification	<ul style="list-style-type: none"> • Installer.
PPE required	<div style="display: flex; align-items: center;">      </div> <div style="background-color: #f96; padding: 5px; margin-top: 5px;">  WARNING! </div> <p>The PPE listed in this table is related to the risk associated with the equipment. For the PPE required to protect against risks associated with the workplace, installation or operating conditions, please refer to:</p> <ul style="list-style-type: none"> • the regulations in force in the country of installation; • <u>any information provided by the Safety Manager at the installation facility.</u>

Tab. 6.20.

6.2 - SPECIFIC SAFETY INSTRUCTIONS FOR THE INSTALLATION STEP

WARNING!

Before proceeding with installation, make sure that the upstream and downstream valves installed on the line are shut off.

WARNING!

Installation may also take place in areas where there is a risk of explosion, which implies that all necessary prevention and protection measures have to be taken.

For these measures, please refer to the regulations in force at the place of installation.

WARNING!

Near the equipment, do not:

- use open flames (e.g. for welding operations);
- smoke.

WARNING!

The equipment must be installed away from atmospheric agents and direct sunlight.

WARNING!

The room where the equipment is installed must:

- be properly aerated/ventilated;
- have an ambient temperature of use as indicated in paragraph 4.5 (“Technical characteristics/performance”).

WARNING!

The installer must:

- use the fittings and gaskets supplied with the equipment by PIETRO FIORENTINI S.p.A.
- fix the swivel joints (when provided) according to the tightening torques specified by standards: NF E29-533: 2014 and NF E29-536: 2017.

ATTENTION!

Do not use the equipment as a reference template (available on request).

6.3 - GENERAL INFORMATION ON THE LINE

The device must be installed in the line, with the arrow on its body pointing to the gas flow direction.
In the typical and most frequent installation, the following must be available:

Pos.	Description
1	Pressure regulator.
2	Shut-off valve upstream of the equipment (1).
3	Shut-off valve downstream of the equipment (when required).
4	Gas meter (if any).

Tab. 6.21.

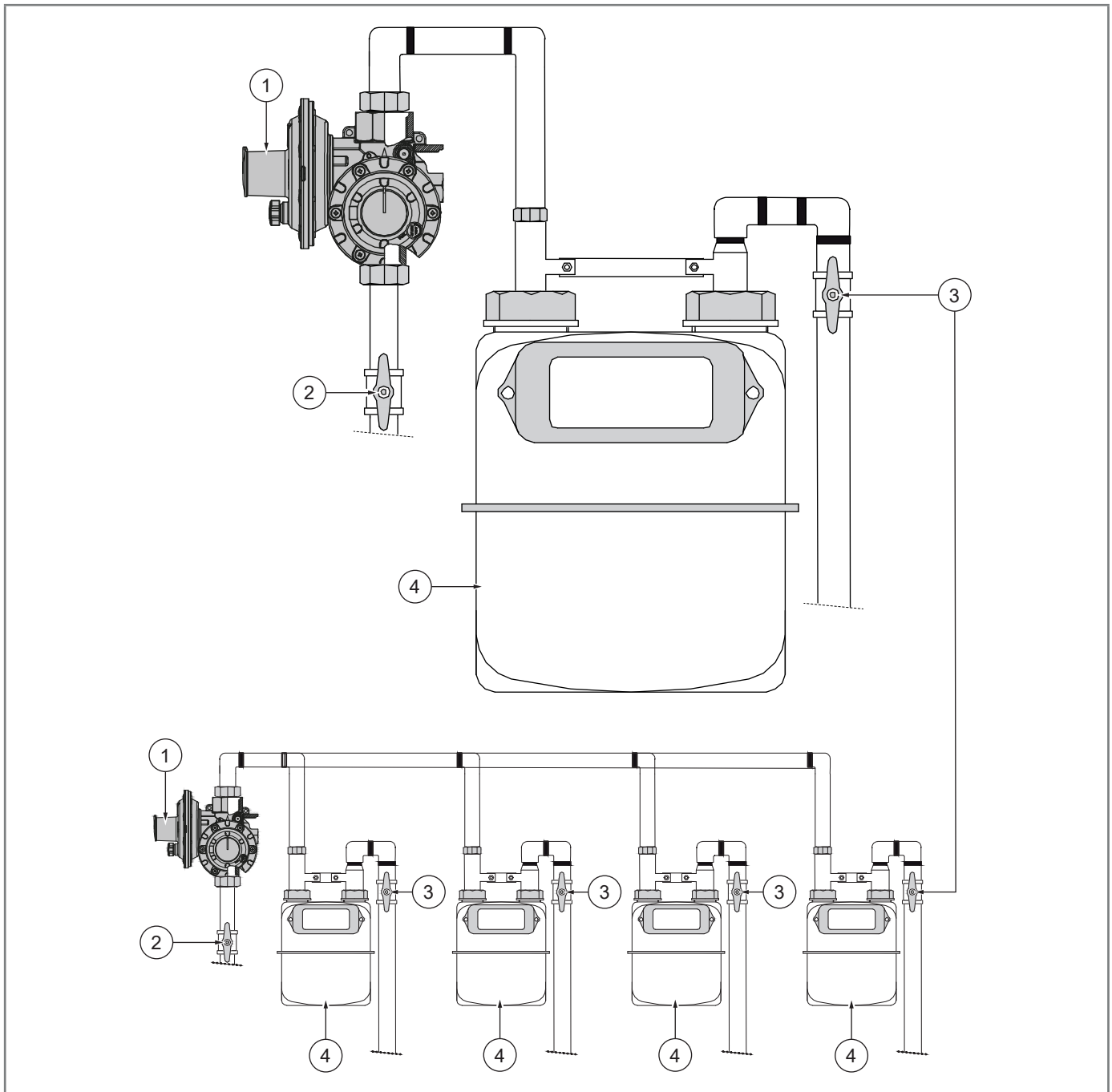

Fig. 6.10. Connection examples

! NOTICE!

When used in gas pressure reduction stations, the device must be installed at least according to the requirements of standards UNI EN 12186:2014 or UNI EN 12279:2007.

Equipment vents must be ducted in accordance with UNI EN 12186:2014 or UNI EN 12279:2007 or the standards in force at the place of installation of the equipment.

6.4 - INSTALLATION PROCEDURES

! NOTICE!

- With natural gas or other non-corrosive gases that are not subject to recondensation, the equipment can be installed in any flow direction.
- Please avoid any mounting positions with outlet flow facing upwards in installations using LPG.

For information about how to mount the regulator in keeping with the available models and configurations (see paragraph 4.4. of the manual), refer to Tab. 6.34.:

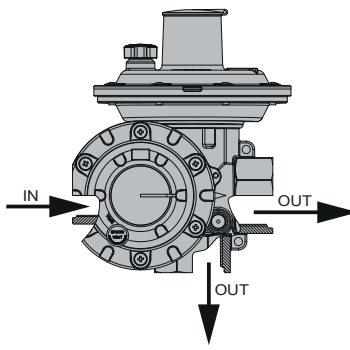
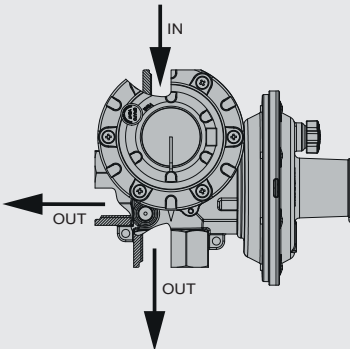
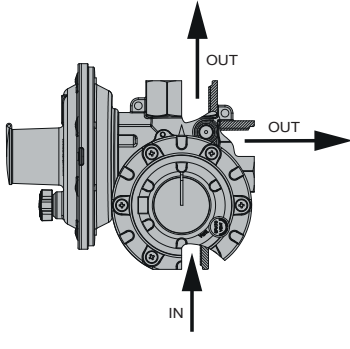
Ref.	Flow direction	Image
A	Horizontal flow	
B	Vertical flow (from top to bottom)	
C	Reversed vertical flow (from bottom to top)	

Tab. 6.22.

To install the equipment, proceed as specified in Tab. 6.35.:

Step	Action
1	Apply the checks in paragraph 6.1.3 (“Checks before installation”).
2	Remove any type of packaging/equipment protection (if any).
3	<p>Connect making sure that:</p> <ul style="list-style-type: none"> the inlet and outlet pipes do not exert excessive bending or traction forces on the regulator body as a result of not being aligned. If necessary, clamp the inlet/outlet pipes for proper alignment; the connections and/or terminals of the inlet and outlet pipes are suitable for and compatible with the fittings on the regulator. <div style="border: 1px solid black; padding: 5px;"> <p>! NOTICE!</p> <ul style="list-style-type: none"> If there are swivel connectors, use the gaskets supplied by PIETRO FIORENTINI S.p.A. In case of direct assembly in the regulator body, use only cylindrical GAS connections (ref. UNI EN ISO 228-1). </div>

Tab. 6.23.

! NOTICE!

The warranty shall be deemed null and void and PIETRO FIORENTINI S.p.A. shall not be held liable for any damage and/or malfunctions if the fittings used during installation are not those supplied.

6.4.1 - POST-INSTALLATION INSTRUCTIONS

! WARNING!

Make sure all connections are properly tightened to prevent any leakage during commissioning.

! WARNING!

Protect the regulator from blows and impacts, even accidental.



6.5 - EQUIPMENT ADJUSTMENTS

NOTICE!

All regulators are calibrated to the values requested by the customer directly at PIETRO FIORENTINI S.p.A. factory.

No further adjustments are required.

The calibration values are specified on the nameplate (refer to paragraph 2.8).

Adjustment	
Operator qualification	<ul style="list-style-type: none"> Installer.
PPE required	<div style="display: flex; align-items: center;">  </div> <div style="background-color: #f4a460; padding: 5px; margin-top: 5px;">  WARNING! </div> <p>The PPE listed in this table is related to the risk associated with the equipment. For the PPE required to protect against risks associated with the workplace, installation or operating conditions, please refer to:</p> <ul style="list-style-type: none"> the regulations in force in the country of installation; <u>any information provided by the Safety Manager at the installation facility.</u>

Tab. 6.24.

If it is necessary to change the calibration values, proceed as indicated in Tab. 6.37. to increase or decrease the operating pressure:

Step	Action	Necessary equipment
1	Remove the upper cap (A) of the regulator.	-
2	Turn the ring nut (B) clockwise <ul style="list-style-type: none"> hourly to increase downstream pressure; anti-clockwise to decrease the downstream pressure. 	27 mm tubular socket wrench
3	Put the upper cap (A) of the regulator back in place.	-
4	Remove the cap of the slam-shut device (C).	-
5	Turn the ring nut (D): <ul style="list-style-type: none"> clockwise to increase the slam-shut valve's cut-in pressure for maximum downstream pressure; anti-clockwise to decrease the slam-shut valve's tripping pressure due to maximum downstream pressure. 	27 mm tubular socket wrench

Step	Action	Necessary equipment
6	Turn the ring nut (E) in the direction: <ul style="list-style-type: none"> clockwise to increase the slam-shut valve's cut-in pressure for minimum downstream pressure; anti-clockwise to decrease the slam-shut valve's tripping pressure due to minimum downstream pressure. 	13 mm tubular socket wrench
7	Put the cap of the slam-shut device (C) back in place.	-

Tab. 6.25.

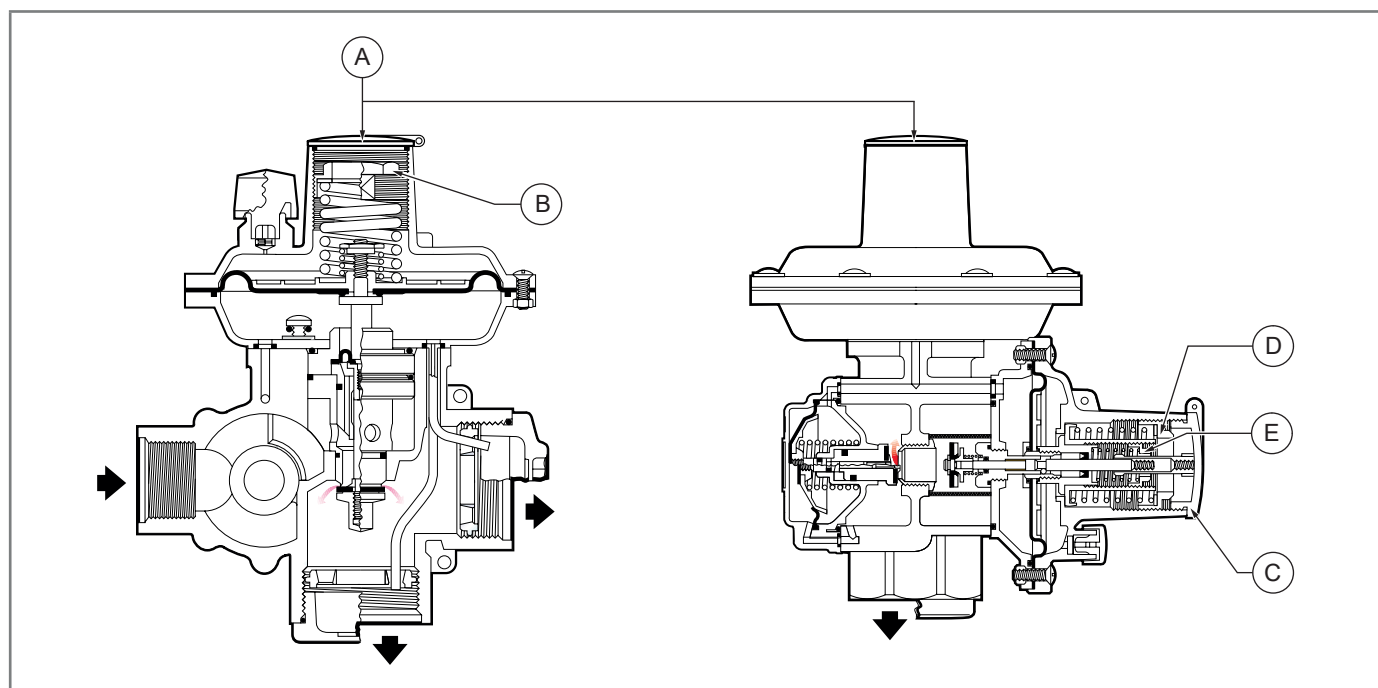

Fig. 6.11. Operating pressure regulation

NOTICE!

Minor $\pm 10\%$ calibration changes with respect to the nameplate value (see paragraph 2.8 “Nameplates applied”) can be made only by adhering to the spring ranges specified in the tables in chapter 10 (“Calibration tables”).

NOTICE!

The relief valve pressure does not need to be adjusted.

WARNING!

Contact PIETRO FIORENTINI S.p.A. for any further need.
Do not make any unauthorised changes to the equipment without the approval of PIETRO FIORENTINI S.p.A.

7 - COMMISSIONING

7.1 - GENERAL WARNINGS

7.1.1 - SAFETY REQUIREMENTS FOR COMMISSIONING

HAZARD!

During commissioning the risks associated with any discharges to the atmosphere of flammable or noxious gases must be evaluated.

HAZARD!

In case of installation on distribution networks for natural gas, consider the risk associated with explosive mixtures (gas/air) being formed inside the piping, if the line is not subjected to inerting.

WARNING!



During commissioning, remove any unauthorised personnel.

NOTICE!

Commissioning has to be carried out by authorised and qualified personnel.

Before commissioning the equipment, it is necessary to check that all shut-off valves (inlet, outlet, bypass if any) are closed.

Commissioning

Operator qualification	<ul style="list-style-type: none"> Commissioning technician.
PPE required	<div data-bbox="414 1167 758 1232">  </div> <div data-bbox="414 1243 1474 1473"> <p> WARNING!</p> <p>The PPE listed in this table is related to the risk associated with the equipment. For the PPE required to protect against risks associated with the workplace, installation or operating conditions, please refer to:</p> <ul style="list-style-type: none"> the regulations in force in the country of installation; any information provided by the Safety Manager at the installation facility. </div>

Tab. 7.26.

7.2 - PRELIMINARY PROCEDURES FOR COMMISSIONING

HAZARD!

Before commissioning the equipment, it must be ensured that any risk of explosion or ignition source has been eliminated.

WARNING!

Before commissioning, it must be ensured that:

- the conditions of use comply with the characteristics of the equipment;
- during pressurisation, the equipment has no leaks.

ATTENTION!

To protect the equipment from damage, never:

- pressurise the equipment through a valve located downstream of it;
- depressurise the equipment through a valve located upstream of it.

7.3 - CALIBRATION OF SAFETY DEVICES

NOTICE!

The equipment is regulated at PIETRO FIORENTINI S.p.A. production plants

WARNING!

Do not tamper with or make any unauthorised changes to the equipment without the approval of PIETRO FIORENTINI S.p.A.

7.4 - COMMISSIONING THE REGULATOR

NOTICE!

Commissioning has to be carried out by authorised and qualified personnel.

Commissioning occurs by directly injecting gas into the pipes at a limited speed (maximum permitted value 5 m/s).

7.4.1 - COMMISSIONING OF THE REGULATOR WITH SLAM-SHUT VALVE

For commissioning of the regulator (A), with shut-off device for maximum/minimum downstream pressure, proceed as shown in Tab. 7.39.:

Step	Action
1	Slowly open the shut-off valve upstream of the regulator (A) to feed it.
2	Unscrew the protective cap (B).
3	Remove the reset extension (C) from the protective cap (B) and screw it onto the slam-shut device stem (D).
4	Slowly pull the reset extension (C) until the plug by-pass is activated. When the by-pass is completed, pull the reset extension (C) all the way back.
4	<div style="border: 1px solid blue; padding: 5px;"> <p>! NOTICE!</p> <p>The resistance encountered when pulling the reset extension (C) will be all the greater the higher the pressure upstream of the regulator (A).</p> </div>
5	Check that the slam-shut valve for maximum downstream pressure remains engaged.
5	<div style="border: 1px solid blue; padding: 5px;"> <p>! NOTICE!</p> <p>The slam-shut valve will be reset if the reset extension (C1) protrudes approx. 15 mm from the cover.</p> </div>
6	Unscrew the reset extension (C) from the slam-shut device stem (D) and reposition it in the protective cap (B).
7	Put the protection cap (B) back in place.

Tab. 7.27.

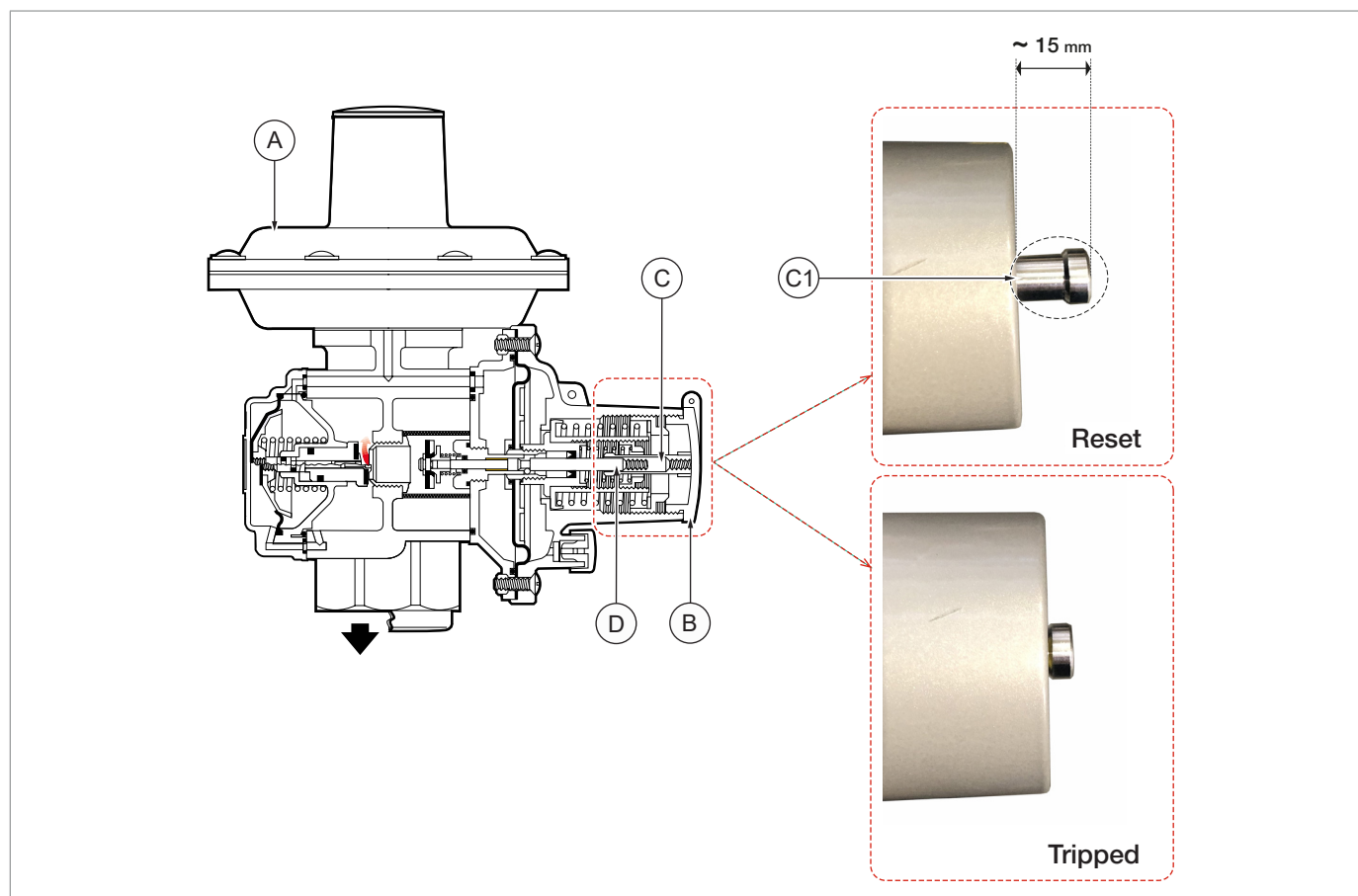

Fig. 7.12. Start-up with slam-shut valve

7.4.2 - COMMISSIONING OF THE REGULATOR WITHOUT SLAM-SHUT VALVE

NOTICE!

During commissioning there may be a slight leakage of gas from the exhaust duct (B).

For commissioning the regulator (A) without slam-shut valve, proceed as shown in Tab. 7.40.:

Step	Action
1	Slowly open the shut-off valve upstream of the regulator (A) to feed it.

Tab. 7.28.

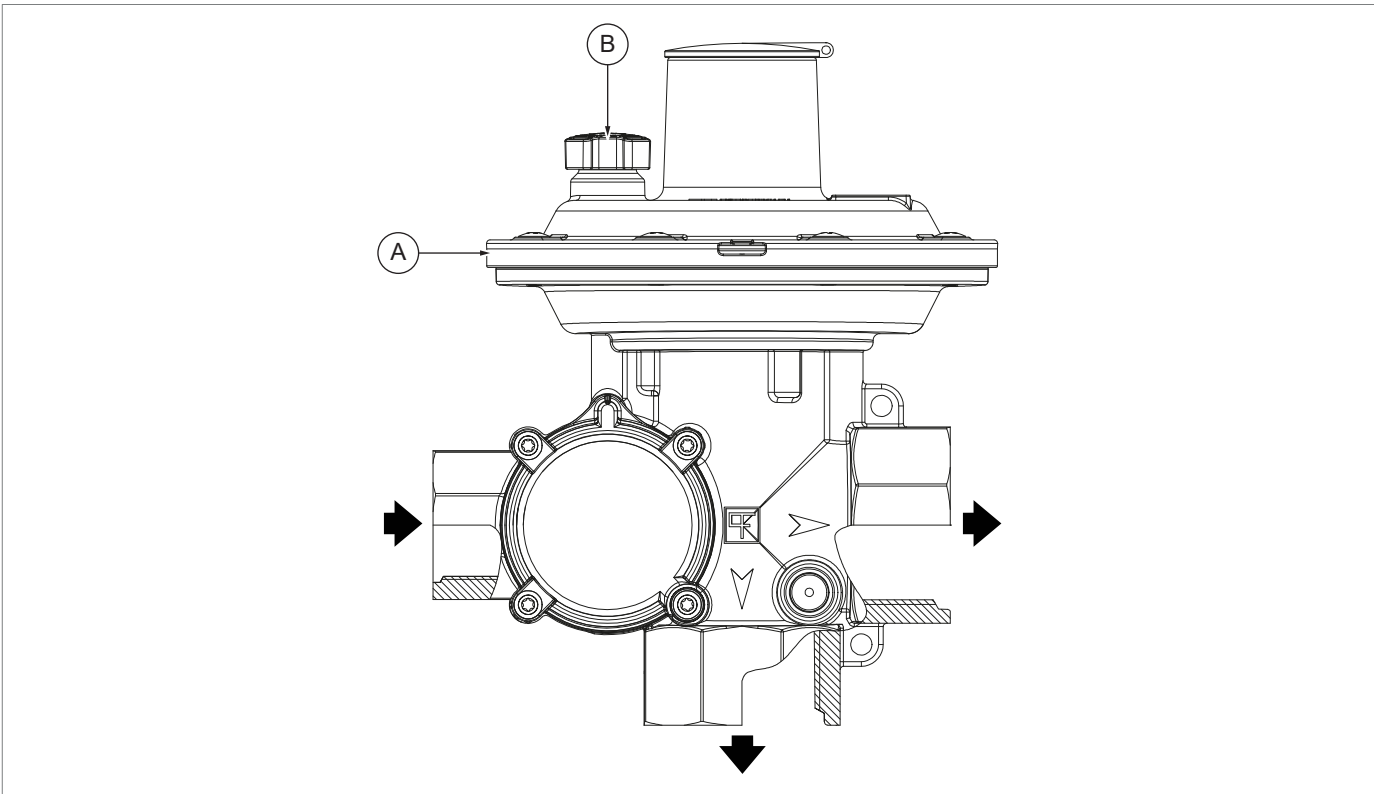

Fig. 7.13. Commissioning without slam-shut valve

7.5 - PROPER COMMISSIONING CHECK

Check the connections made during the installation of the equipment (refer to chapter 6 “Installation”) for proper sealing through a foaming solution (or equivalent control system).

7.6 - RESET OF SAFETY DEVICES AFTER COMMISSIONING

HAZARD!

Before resetting the safety devices, eliminate the causes that caused them to trip.

ATTENTION!

- The maximum pressure slam-shut device will not be reset if the fault has not been eliminated in the network downstream of the reducers.
- The minimum pressure slam-shut device will not be reset if the fault has not been eliminated in the network downstream of the reducers.

NOTICE!

During reset of the safety device, the relief valve may temporarily trip.

7.7 - DRUM ASSEMBLY (UNDERGROUND VERSION OF THE REGULATOR)

! NOTICE!

The drum must only be assembled for the underground version of the regulator.

7.7.1 - DRUM ASSEMBLED TO THE SLAM-SHUT VALVE COVER

! NOTICE!

The drum must always be in a horizontal position with the camera facing the ground.

After the equipment has been commissioned (see section 7.4), proceed as shown in Tab.7.41 for mounting the drum on the slam-shut valve cover (A):

Step	Action
1	Unscrew the screw (B) anti-clockwise, taking care that the o-ring remains in place.
2	Insert the drum (C) on the brass fitting (E), <div style="border: 1px solid black; padding: 5px; margin-top: 5px;"> ! NOTICE! Position the drum (C) in such a way that the rubber tube (D) of the regulator vent is in a vertical position inside the drum. </div>
3	Tighten screw (B) in a clockwise direction to ensure locking and tightness of the system.
4	Check that the drum (C) is in a horizontal position.

Tab. 7.29.

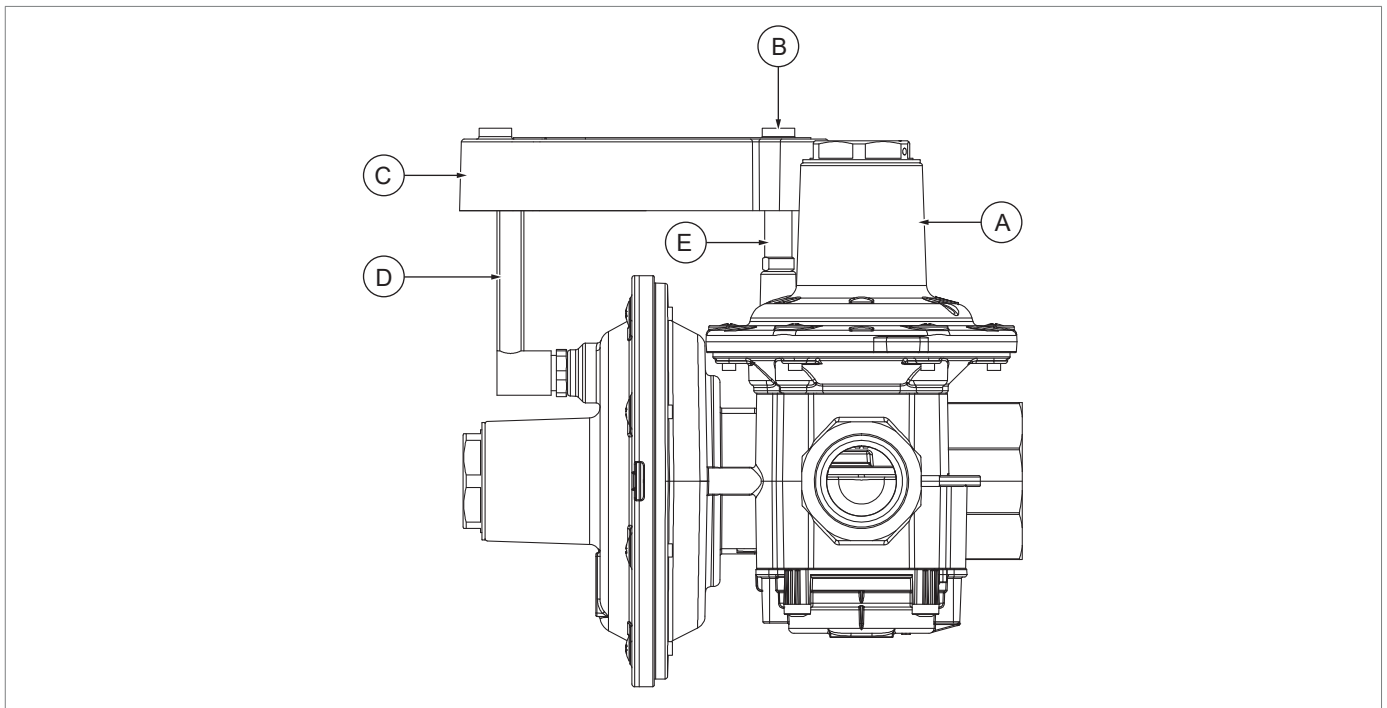

Fig. 7.14. Drum assembled to the slam-shut valve cover (regulator underground version)

7.7.1.1 - REGULATOR RESET

To reset the underground version of the regulator with drum fixed on the slam-shut valve cover, proceed as indicated in Tab. 7.42.:

Step	Action
1	Unscrew the screw (B) anti-clockwise.
2	Remove the drum (C) from the brass fitting (E).
3	Commission the equipment (see paragraph 7.4).
4	Check the presence of the o-ring on the brass fitting (E).
5	Insert the drum (C) on the brass fitting (E), <div style="border: 1px solid blue; padding: 5px; margin-top: 5px;"> <p>! NOTICE! Position the drum (C) in such a way that the rubber tube (D) of the regulator vent is in a vertical position inside the drum.</p> </div>
6	Tighten screw (B) in a clockwise direction to ensure locking and tightness of the system.
7	Check that the drum (C) is in a horizontal position.

Tab. 7.30.

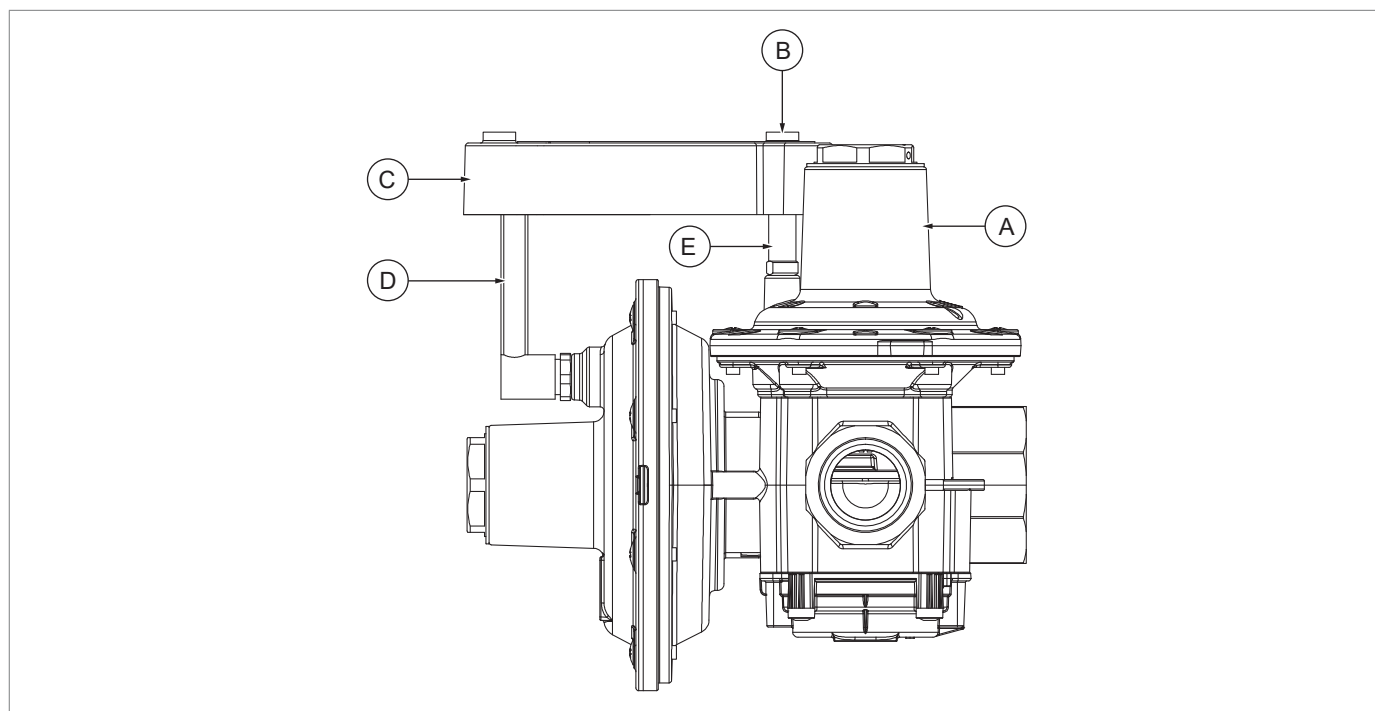

Fig. 7.15. Resetting of the underground regulator with drum fixed on the slam-shut valve cover

7.7.2 - DRUM FIXED ON THE SECOND STAGE CONTROL HEAD

! NOTICE!

The drum must always be in a horizontal position with the camera facing the ground.

After commissioning the equipment (see section 7.4), for mounting the drum fixed on the second stage control head (A), proceed as shown in Tab. 7.43.:

Step	Action
1	Unscrew the throttle screw (B) anticlockwise, making sure that the O-ring (C) remains in its seat.
2	Screw the brass fitting (F) onto the regulator cover.
3	Insert the drum (D) on the brass fitting (F), <div style="border: 1px solid black; padding: 5px; margin-top: 5px;"> <h3>! NOTICE!</h3> <p>Position the drum (D) in such a way that the rubber tube (E) of the regulator vent is in a vertical position inside the drum.</p> </div>
4	Tighten the butterfly screw (B) in a clockwise direction to ensure locking and tightness of the system.
5	Check that the drum (D) is in a horizontal position.

Tab. 7.31.

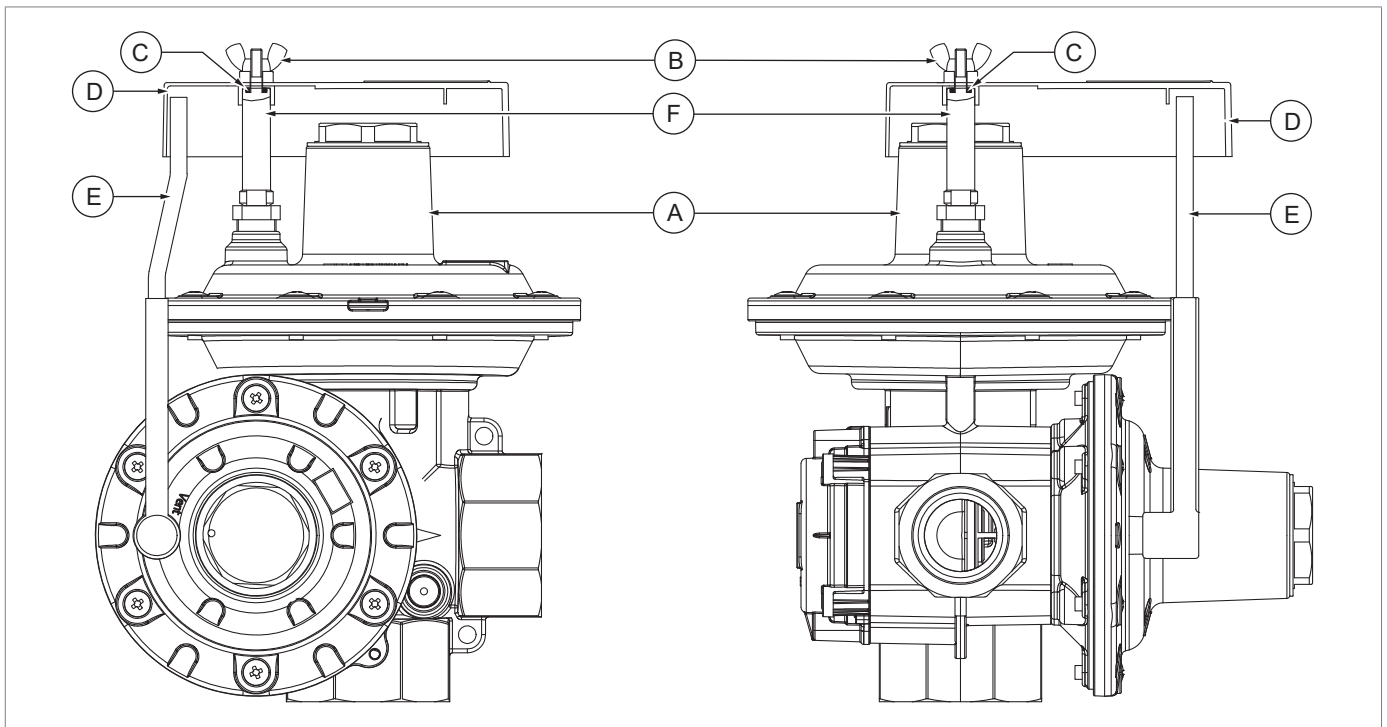

Fig. 7.16. Drum fixed on the second stage control head (underground regulator)

8 - FUNCTIONAL CHECKS

8.1 - GENERAL WARNINGS

 **NOTICE!**

The equipment does not need any periodic checks and maintenance procedures.

 **HAZARD!**

PIETRO FIORENTINI S.p.A. shall not be held liable for any damage to people and property due to services provided without its approval.

 **WARNING!**

If you have doubts or there are any functional faults, do not operate. Contact PIETRO FIORENTINI S.p.A. for the necessary clarifications.

In the event of equipment faults, proceed as follows:

Step	Action
1	Close the shut-off valve downstream of the equipment.
2	Close the shut-off valve upstream of the equipment.
3	Ensure that the pressure upstream and downstream of the equipment is "0".
4	Contact PIETRO FIORENTINI S.p.A.

Tab. 8.32.

8.2 - PERIODICALLY CHECKING AND INSPECTING THE EQUIPMENT FOR PROPER OPERATION



HAZARD!

Checks and inspections must be carried out only by qualified technicians.

Periodic checks and inspections

Operator qualification	<ul style="list-style-type: none"> Commissioning technician.
PPE required	 <p>WARNING!</p> <p>The PPE listed in this table is related to the risk associated with the equipment. For the PPE required to protect against risks associated with the workplace, installation or operating conditions, please refer to:</p> <ul style="list-style-type: none"> the regulations in force in the country of installation; any information provided by the Safety Manager at the installation facility.

Tab. 8.33.

8.2.1 - FUNCTIONAL CHECKS OF SAFETY DEVICES

To check the safety devices for proper operation, it is necessary:

- that the system has a shut-off valve downstream of the regulator;
- that the system is set up with a pressure outlet downstream of the regulator or that the regulator is equipped with a built-in pressure outlet (see paragraph 4.6.4);
- that an external pressure source with pressure control is available;
- that the external pressure source is connected to a pressure gauge and to a tap with a 4 mm maximum flow section.



NOTICE!

Gas dispersions in the environment must be reduced to the bare minimum.

To check the safety devices, proceed as described in Tab. 8.46.:

Step	Action
1	Close the valve downstream of the regulator.
2	Prepare the external pressure source with a pressure gauge to monitor the pressure. <p>NOTICE!</p> <p>The maximum pressure introduced downstream of the regulator must not exceed:</p> <ul style="list-style-type: none"> 300 mbar for the BP version; 1 bar for the MP version.
3	Connect the external pressure source to the pressure outlet downstream of the system or, if any, to the pressure outlet on the regulator. <p>NOTICE!</p> <p>To use the pressure outlet on the regulator, see paragraph 4.6.4.</p>
4a	Pds (adjusted pressure) check: <ol style="list-style-type: none"> open the tap of the external pressure source; check that the pds value is $\pm 10\%$ with respect to the value indicated on the nameplate applied.
4b	Internal sealing check: <ol style="list-style-type: none"> close the tap of the external pressure source; check that the downstream pressure value is stable over time (wait for about 2 minutes).

Step	Action
4c	<p>Checking the slam-shut device for tripping due to maximum/minimum downstream pressure:</p> <ol style="list-style-type: none"> open the external pressure source by increasing the pressure by approximately: <ul style="list-style-type: none"> 2 mbar/s for the BP version; 5 mbar/s for the MP version; until the slam-shut device trips due to maximum pressure when the reset extension trips; check that the tripping value of the slam-shut device is $\pm 15\%$ with respect to the value indicated on the nameplate applied (pdso); reset the regulator lock; close the external pressure source; close the tap located upstream of the regulator; open the tap of the external pressure source so that the pressure decreases by approx: <ul style="list-style-type: none"> 2 mbar/s for the BP version; 5 mbar/s for the MP version; check that the tripping value of the slam-shut device is $\pm 15\%$ with respect to the value indicated on the nameplate applied (pdsu). <div style="border: 1px solid black; padding: 5px; margin-top: 10px;"> <p>NOTICE!</p> <p>If the pressure increase is difficult due to the opening of the relief valve, it is possible to partially plug the discharge conveyer (A) on the second stage cover with a finger to allow the pressure to increase downstream of the regulator.</p> </div>
5	Disconnect the external pressure source outlet.
6	Close the downstream pressure outlet (Step 3).
7	Open the shut-off valve which was closed in Step 1 .
8	Carry out commissioning as described in Section 7.4.
9	Check that there are no leaks at the shut-off pressure outlet in Step 6 .

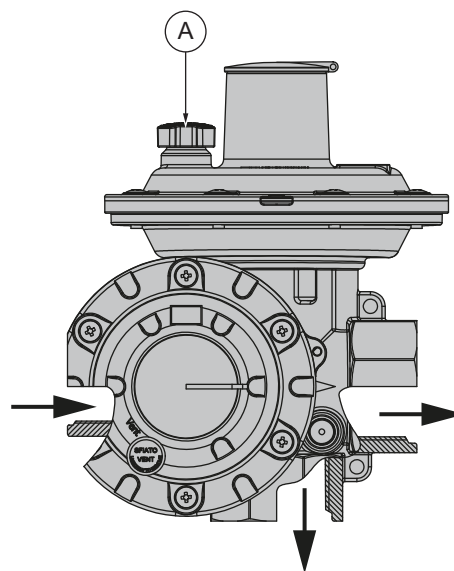

Tab. 8.34.

8.3 - TIGHTENING TORQUES

 **NOTICE!**

For the tightening torques of the swivel joints, refer to standards: NF E29-533: 2014 and NF E29-536: 2017.

9 - UNINSTALLATION AND DISPOSAL

9.1 - GENERAL SAFETY WARNINGS

HAZARD!



Make sure that there are no potentially explosive ignition sources in the work area set up to uninstall and/or dispose of the equipment.

WARNING!

Before proceeding with uninstallation and disposal, make the equipment safe by disconnecting it from any power supply.

9.2 - QUALIFICATION OF THE OPERATORS IN CHARGE

Commissioning

Operator qualification	<ul style="list-style-type: none"> Installer.
PPE required	 <p> WARNING!</p> <p>The PPE listed in this table is related to the risk associated with the equipment. For the PPE required to protect against risks associated with the workplace, installation or operating conditions, please refer to:</p> <ul style="list-style-type: none"> the regulations in force in the country of installation; any information provided by the Safety Manager at the installation facility.



Tab. 9.35.

9.3 - UNINSTALLATION

ATTENTION!

Before uninstalling the equipment, completely drain the fluid in the reduction line and inside the equipment.

To properly uninstall the equipment, proceed as specified in Tab. 9.48.:

Step	Action
1	Close the valves upstream and downstream of the regulator.
2	Depressurise the downstream system. <div style="border: 1px solid black; padding: 5px; margin-top: 10px;">  NOTICE! If there is no pressure outlet downstream, loosen the outlet connection from the regulator, creating a slight leak towards the outside. </div>
3	Unscrew the inlet and outlet fittings of the regulator. <div style="background-color: yellow; padding: 5px; margin-top: 10px;">  ATTENTION! Although the system is depressurised (Step 2), there may be a small gas discharge while the inlet fittings are disassembled. </div>

Tab. 9.36.

9.4 - INFORMATION REQUIRED IN CASE OF NEW INSTALLATION

NOTICE!

Should the equipment be reused after uninstallation, please refer to chapters: “Installation” and “Commissioning”.

9.5 - DISPOSAL INFORMATION

NOTICE!

- Proper disposal prevents damage to humans and the environment and promotes the reuse of precious raw materials.
- Bear in mind that the regulations in force in the country of installation must be complied with.
- Illegal or improper disposal involves the application of the penalties provided for by the regulations in force in the country of installation.

The equipment was manufactured with materials that can be recycled by specialised companies. For proper disposal of the equipment, proceed as specified in Tab. 9.49.:

Step	Action
1	Set up a large work area free from obstacles where to safely dismantle the equipment.
2	Sort the various components by type of material for easier recycling through separate collection.
3	Send the materials obtained in Step 2 to a specialised company.

Tab. 9.37.

The equipment in all possible configurations consists of the materials listed in Tab. 9.50

Material	Present in	Disposal/recycling indications
Nitrile rubber (MP rubberised canvas)	<ul style="list-style-type: none"> • Diaphragm • O-rings 	It must be dismantled and disposed of separately.
Plastic	<ul style="list-style-type: none"> • Caps • Discs 	It must be dismantled and disposed of separately.
Steel	<ul style="list-style-type: none"> • Springs 	Disassemble and collect separately. It must be recycled through the specific collection centres.
Aluminium alloy	<ul style="list-style-type: none"> • Equipment body • Lids • Seat 	Disassemble and collect separately. It must be recycled through the specific collection centres.

Tab. 9.38.

NOTICE!

The above materials refer to standard versions. Different materials can be provided for specific needs.

10 - CALIBRATION TABLES

10.1 - CALIBRATION TABLES

NOTICE!

When the value indicated on the regulator plate is equal to the minimum or maximum value of a spring referred to in the tables (Tab.10.51. , Tab.10.52., Tab.10.53., Tab.10.54., Tab.10.55. e Tab.10.56.), the spring installed in the regulator is the one featuring the minimum range value equal to the calibration value specified on the data plate.

BP FEX 50-75-100 REGULATION							
Pos.	Spring item code	Spring colour	d	Lo	De	Spring range (mbar)	
						Min.	Max.
1	64470171BI	White	1.8	57	34	13	19
	64470027VER	Green	1.2	30	15.4		
2	64470130AR	Orange	1.8	78	34	20	26
	64470030NER	Black	1.2	35	15		
3	64470131VE	Green	2.2	70	34	27	39
	64470030NER	Black	1.2	35	15		
4	64470132RO	Red	2.4	67	34	40	59
	64470030NER	Black	1.2	35	15		
5	64470133BL	Blue	2.4	84	34	60	79
	64470030NER	Black	1.2	35	15		
6	64470134AZ	Light Blue	3	65	34	80	99
	64470030NER	Black	1.2	35	15		

d = Wire Diameter (mm) **Lo** = Spring Length (mm) **De** = External Diameter (mm)

Tab. 10.39.

BP FEX 50-75-100 SLAM-SHUT VALVE FOR OVERPRESSURE							
Pos.	Spring item code	Spring colour	d	Lo	De	Spring range (mbar)	
						Min.	Max.
1	64470111VE	Green	2	45	34	32	54
2	64470113AZ	Light Blue	2.3	44	34	55	99
3	64470114MA	Brown	2.4	51	34	100	160

d = Wire Diameter (mm) **Lo** = Spring Length (mm) **De** = External Diameter (mm)

Tab. 10.40.

BP FEX 50-75-100 SLAM-SHUT VALVE FOR UNDERPRESSURE							
Pos.	Spring item code	Spring colour	d	Lo	De	Spring range (mbar)	
						Min.	Max.
1	64470308NE	Black	1.1	29.5	15.2	6	14
2	64470128VE	Green	1.3	35	15	15	39
3	64470024BI	White	1.3	45	15	40	79
4	64470031RO	Red	1.7	40	15	80	139
5	64470038GI	Yellow	2	40	15	140	250

d = Wire Diameter (mm) **Lo** = Spring Length (mm) **De** = External Diameter (mm)

Tab. 10.41.

RELIEF VALVE BP FEX 50-75-100

Spring item code	Spring range (mbar)	
	Min.	Max.
64470027VER	10	15
64470030NER	16	34

Spring ranges refer to the differential between regulator setting and overflow trip.

Tab. 10.42.
MP FEX 50-75-100 REGULATION

Pos.	Spring item code	Spring colour	d	Lo	De	Spring range (mbar)	
						Min.	Max.
1	64470134AZ	Light Blue	3	65	34	100	119
	64470024BI	White	1.3	45	15		
2	64470135GI	Yellow	3.2	63	34	120	209
	64470024BI	White	1.3	45	15		
3	64470136GR	Grey	3.5	69	34	210	350
	64470040GR	Grey	1.5	44	15		

d = Wire Diameter (mm) **Lo** = Spring Length (mm) **De** = External Diameter (mm)

Tab. 10.43.
MP FEX 50-75-100 SLAM-SHUT VALVE FOR OVERPRESSURE

Pos.	Spring item code	Spring colour	d	Lo	De	Spring range (mbar)	
						Min.	Max.
1	64470115GR	Grey	2.8	42	34	115	209
2	64470116GI	Yellow	3.2	40	34	210	329
3	64470416BI	White	3.1	5481	34	330	500

d = Wire Diameter (mm) **Lo** = Spring Length (mm) **De** = External Diameter (mm)

Tab. 10.44.
MP FEX 50-75-100 SLAM-SHUT VALVE FOR UNDERPRESSURE

Pos.	Spring item code	Spring colour	d	Lo	De	Spring range (mbar)	
						Min.	Max.
1	64470024BI	White	1.3	45	15	40	79
2	64470031RO	Red	1.7	40	15	80	139
3	64470038GI	Yellow	2	40	15	140	250

d = Wire Diameter (mm) **Lo** = Spring Length (mm) **De** = External Diameter (mm)

Tab. 10.45.
RELIEF VALVE MP FEX 50-75-100

Spring item code	Spring range (mbar)	
	Min.	Max.
64470024BI	35	70
64470040GR	71	110

Spring ranges refer to the differential between regulator setting and overflow trip.

Tab. 10.46.

PAGE INTENTIONALLY LEFT BLANK

TM0080ENG

