

# VLM

Control Valve

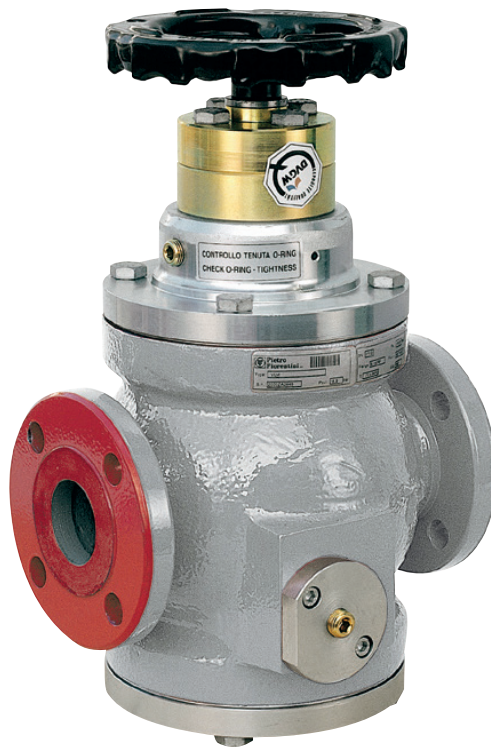

**TECHNICAL BROCHURE**

**Pietro Fiorentini S.p.A.**

Via E.Fermi, 8/10 | 36057 Arcugnano, Italy | +39 0444 968 511  
sales@fiorentini.com

The data are approximate and not binding.  
We reserve the right to make changes without prior notice.

vim\_technicalbrochure\_ENG\_revA

**[www.fiorentini.com](http://www.fiorentini.com)**

# Who we are

We are a leading company in designing and manufacturing technologically advanced devices and systems for natural gas treatment, transmission and distribution.

We are the ideal partner for operators in the Oil & Gas sector, with a business offer that goes across the whole natural gas chain.

We are in constant evolution to meet our customers' highest expectations in terms of quality and reliability.



## Pietro Fiorentini advantages



Local technical support



Since 1940



Active in more than 100 countries

# Application area

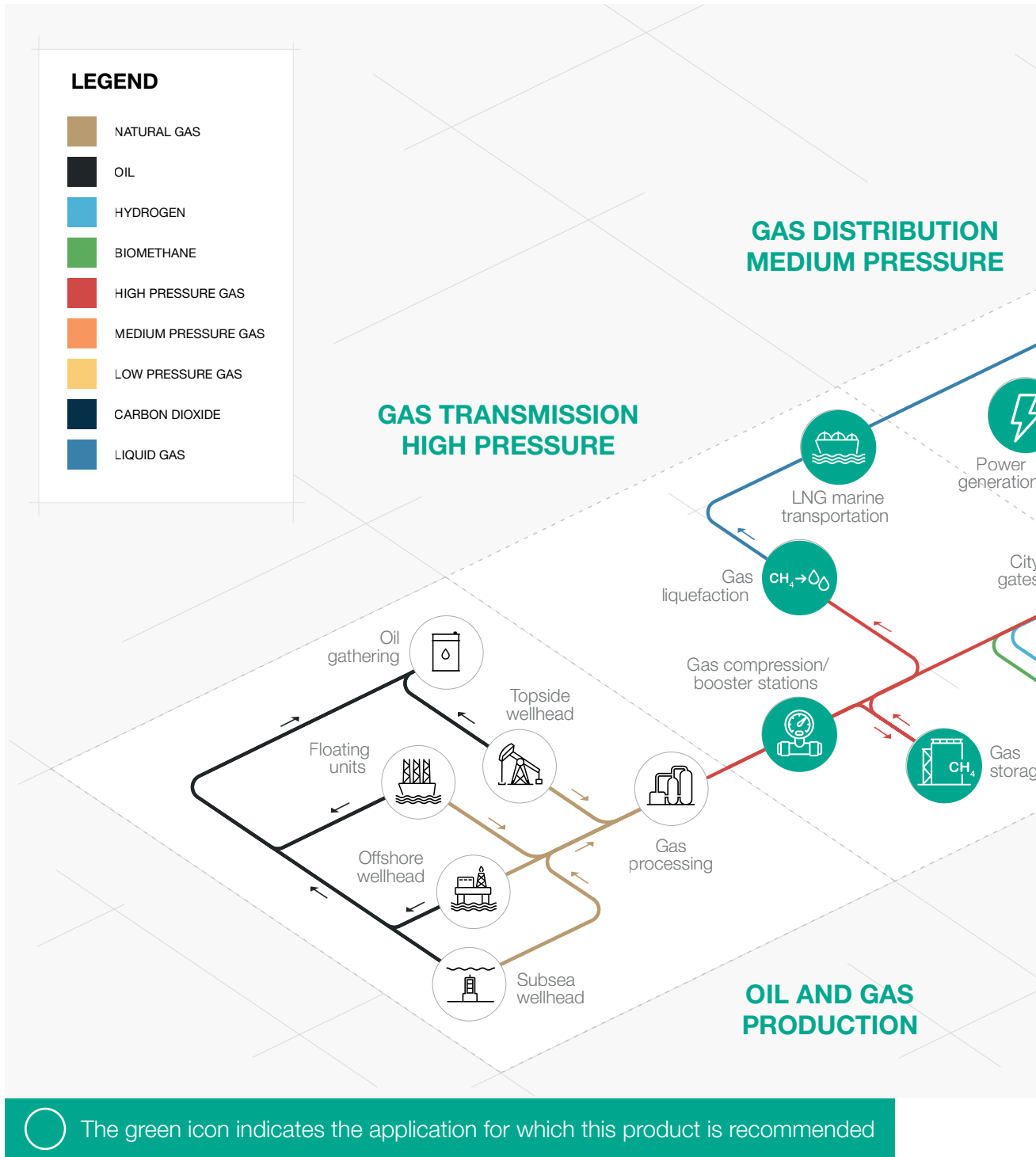

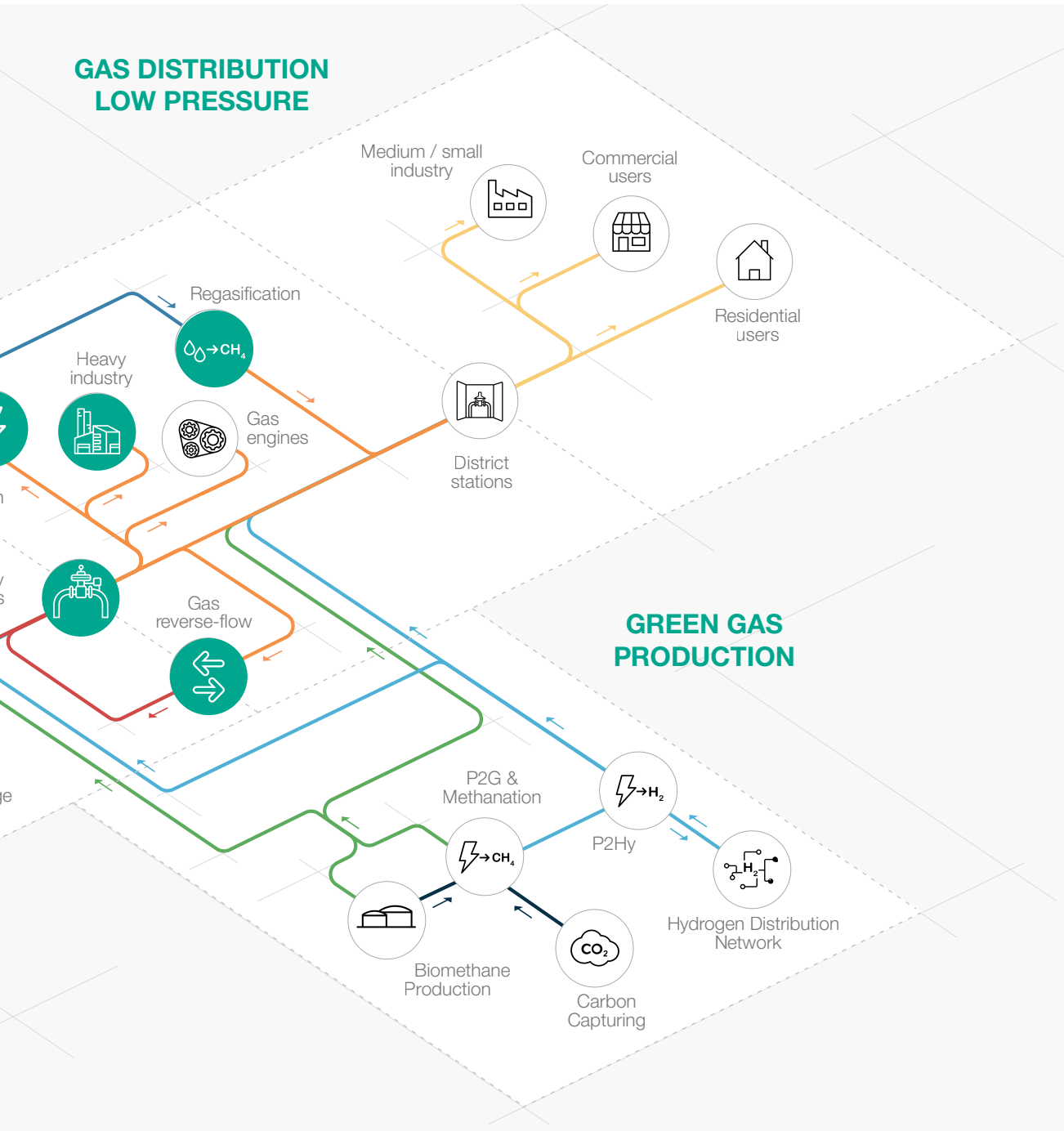
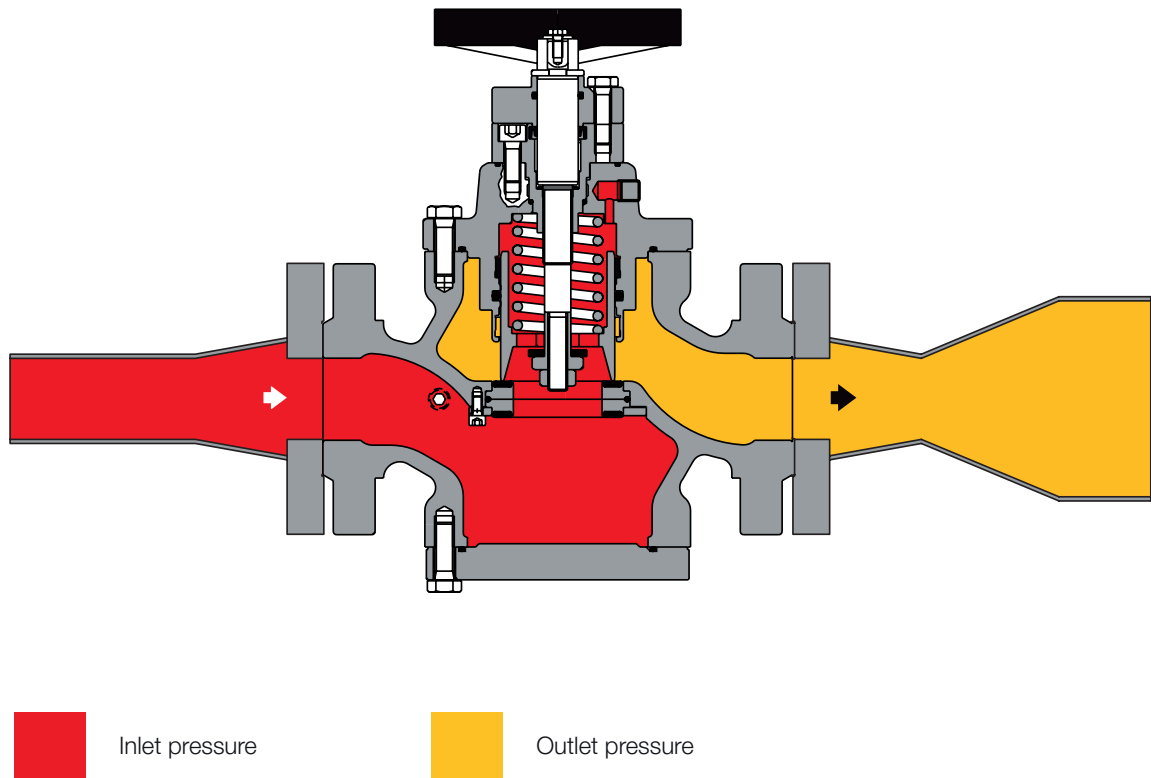

**Figure 1** Application area map

# Introduction

**VLM** valves are shut-off and lamination devices particularly suitable for use within the field of installations for the distribution of natural gas, as well as for supply networks for civil and industrial use. The main features of these valves are:

- body in top-entry execution suitable for flanged coupling;
- soft insert on the seat for a better seal;
- balanced plug for easier opening and closing;
- possibility of incorporating the silencer; the slam-shut valve, the second plug in series with the main one.



**Figure 2** VLM

# Features and Field of application

The **VLM** valve is a manually operated lamination device. This valve is suitable for use with previously treated non-corrosive gases.

It is truly a TOP ENTRY design, which confers important advantages to the valve, for example the ability to perform full maintenance without removing it from the connecting pipes.

The VLM valve has been designed with a high degree of modularity in order to make it possible to incorporate additional devices and accessories.

These can also be added to the basic valve at a later date without having to modify the existing assembly piping.



**Figure 3** VLM



## VLM competitive advantages



Compact design



Low noise level



Top entry



Built-in accessories



Easy Maintenance



Available in special versions for blended hydrogen

## Features

Features	Values
Maximum inlet pressure	Up to 100 barg
Room temperature	from -20 °C to +60 °C from -4 °F to +140 °F
Inlet gas temperature	from -20°C to + 60°C from -4 °F to +140 °F
Nominal dimensions DN	DN 25 / 1"; DN 50 / 2"; DN 80 / 3"; DN 100 / 4"; DN 150 / 6"; DN 200 / 8";
Connections	Class 150-300-600 RF or RTJ, complies with ANSI B16.5 and PN 16 as per EN 1092, ISO 7005.
NOTE: Different operating features available on request.	

**Table 1** Features

# Materials and Certifications

Part	Materials
Body	ASTM A 352 LCB steel for ANSI 600 and 300 classes; ASTM A 216 WCB steel and ductile iron GS 400-18 ISO 1083 for ANSI 150 and PN 16 classes.
Control	ASTM A 350 LF2 steel
Stem	AISI 416 stainless steel
Plug	ASTM A 350 LF2 Nickel coated
Seat	Vulcanised Nitrile Rubber on metal support,
O-rings	Nitrile rubber

NOTE: The above materials refer to standard versions. Different materials can be provided for specific needs.

**Table 2** Materials

## Construction Standards and Certifications

The product is certified according to European Directive 2014/68/EU (PED).

Tightness class: class VI as per ANSI/FCI 70-2.



PED-CE

# Accessories

## VLM valve accessories:



- PM Incorporated monitor
- DB/819 silencer
- SB/82 Slam-Shut device

## PM monitor

The monitor is a safety accessory that performs the functions of the service valve when the main valve fails.

In the case of the VLM valve, the PM Monitor consists of a second VLM valve which is installed on the same body as the main one. The functional characteristics of the PM Monitor are the same as those of the main valve.

The valve's Cg coefficient is 5% lower than the corresponding standard version.

-  Compact dimensions
-  Fully independent
-  Easy maintenance

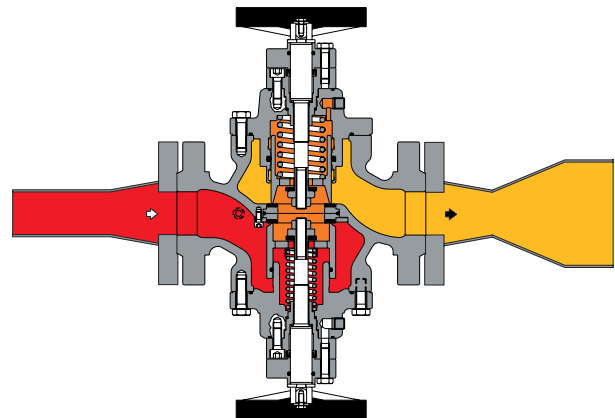

**Figure 4** VLM with incorporated monitor

 Outlet pressure

 Inlet pressure

## Incorporated silencer DB/819

If a certain noise limit is desired, an additional silencer can significantly reduce the noise level (dBA).

The VLM control valve can be supplied with a **built-in silencer**. The high efficiency of this solution is due to the fact that the absorption of the noise takes place at the same point where the noise is generated, thus preventing it from propagating.

With the built-in silencer, the valve's  $C_g$  coefficient is 5% lower than the corresponding version without a silencer.

Due to the modular design of the valve, the silencer can be retrofitted **without having to modify the existing pipes**.

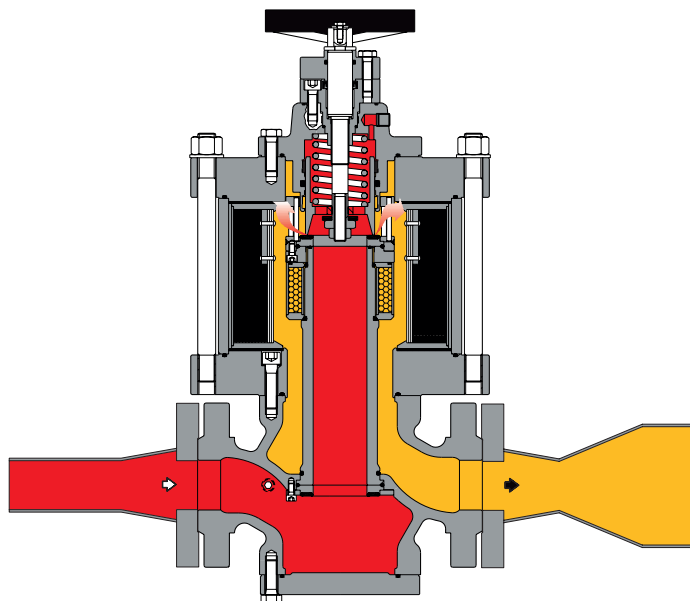

**Figure 5** VLM with DB/819 silencer



Outlet pressure



Inlet pressure









## SB/82 Slam-Shut Device

SB/82 is a **Safety Device** that interrupts the gas flow in case of irregular pressure conditions compared to those set in the pressure switch device.

The VLM control valve offers the possibility of installing the SB/82 slam-shut device, which can be done either during the manufacturing process **or later directly in the field.**

SB/82 is available for all gauges of the VLM control valve; with the built-in slam-shut device, the Cg coefficient of the valve is 5% lower than the corresponding version without.

The main characteristics of this device are:

-  OPSO Overpressure slam-shut device
-  UPSO Underpressure slam-shut device
-  Internal by-pass
-  Tripping test button
-  Compact dimensions
-  Easy Maintenance
-  Optional tripping control
-  Optional limit switch

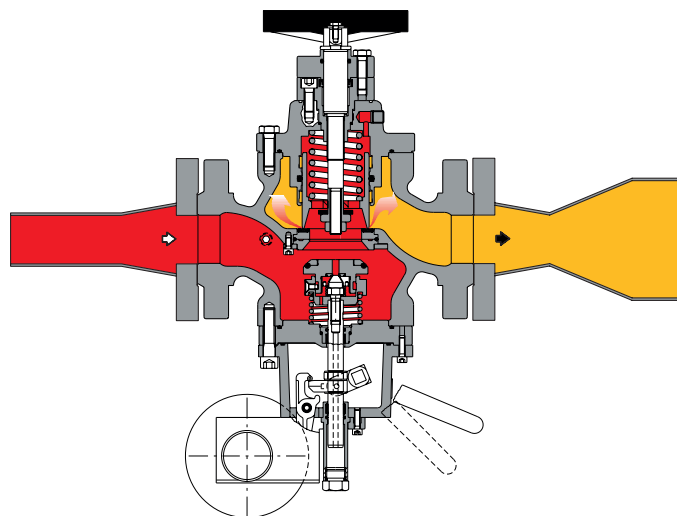

**Figure 6** VLM with slam-shut device SB/82

The shut-off device can be calibrated **for pressure increase, overpressure shut-off (OPSO)** and/or **for pressure reduction, underpressure shut-off (UPSO)**. The two modes of action can be adjusted independently by means of special calibration springs: one spring for overpressure intervention and a second spring for underpressure intervention.

Spring range <b>pressure switches</b>					
Device	Model	Function	Wh Range		Web link spring tables
			MPa	barg	
SB/82	102M	OPSO	0.02 - 0.55	0.2 - 5.5	<a href="#">TT 1331</a>
		UPSO	0.02 - 0.28	0.2 - 2.8	
SB/82	102MH	OPSO	0.02 - 0.55	0.2 - 5.5	<a href="#">TT 1331</a>
		UPSO	0.28 - 0.55	2.8 - 5.5	
SB/82	103M	OPSO	0.2 - 2.2	2 - 22	<a href="#">TT 1331</a>
		UPSO	0.02 - 0.8	0.2 - 8	
SB/82	103MH	OPSO	0.2 - 2.2	2 - 22	<a href="#">TT 1331</a>
		UPSO	0.02 - 0.8	0.2 - 8	
SB/82	104M	OPSO	1.5 - 4.5	15 - 45	<a href="#">TT 1331</a>
		UPSO	0.16 - 1.8	1.6 - 18	
SB/82	104MH	OPSO	1.5 - 4.5	15 - 45	<a href="#">TT 1331</a>
		UPSO	1.8 - 4.1	18 - 41	
SB/82	105M	OPSO	3 - 9	30 - 90	<a href="#">TT 1331</a>
		UPSO	0.3 - 4.4	3 - 44	
SB/82	105MH	OPSO	3 - 9	30 - 90	<a href="#">TT 1331</a>
		UPSO	4.4 - 9	44 - 90	

**Table 3** Adjustment table



# VLM

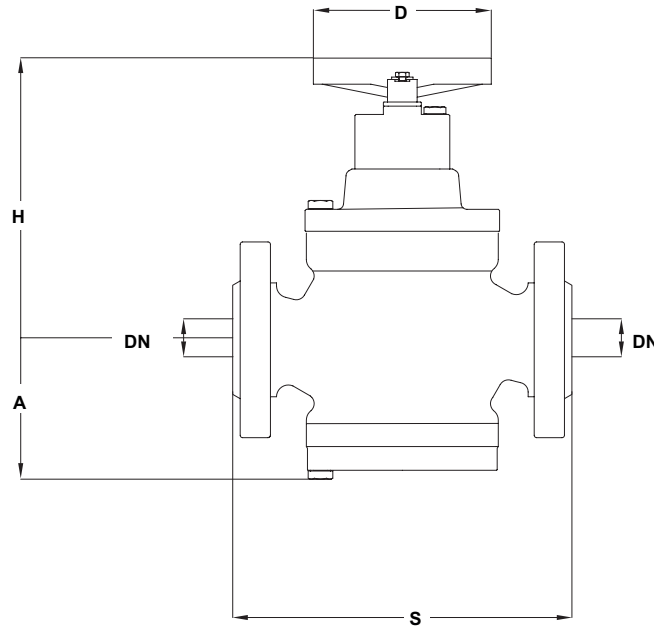

**Figure 7** VLM dimensions

**Weights and Dimensions (for other connections please contact your nearest Pietro Fiorentini sales outlet)**

	[mm]   inches	[mm]   inches	[mm]   inches	[mm]   inches	[mm]   inches	[mm]   inches	[mm]   inches
Dimensions (DN)	25   1"	50   2"	65   2"1/2	80   3"	100   4"	150   6"	200   8"
S - ANSI 150/PN16	183   7.20"	254   10"	276   10.87"	298   11.73"	352   13.86"	451   17.76"	543   21.38"
S - ANSI 300	197   7.76"	267   10.51"	-   -	317   12.48"	368   14.49"	473   18.62"	568   22.36"
S - ANSI 600	210   8.27"	286   11.26"	-   -	336   13.23"	394   13.23"	508   20"	609   23.98"
A	95   3.74"	130   5.12"	135   5.31"	150   1.97"	190   7.48"	250   9.84"	310   12.20"
D	150   1.97"	150   1.97"	150   1.97"	150   1.97"	150   1.97"	250   9.84"	250   9.84"
H	205   8.07"	240   9.45"	265   10.43"	270   10.63"	305   12.00"	420   16.54"	460   18.11"
Tube connections	eØ 10 x iØ 8 (on request imperial sizing)						

Weight	Kg   lbs	Kg   lbs	Kg   lbs	Kg   lbs	Kg   lbs	Kg   lbs	Kg   lbs
ANSI150/PN 16	17   37	32   70	44   97	56   123	82   180	175   385	265   584
ANSI 300	19   42	34   75	-   -	57   125	103   227	185   408	280   617
ANSI 600	20   44	36   79	-   -	61   134	109   240	207   456	315   694

**Table 4** Weights and dimensions

## VLM + DB/819

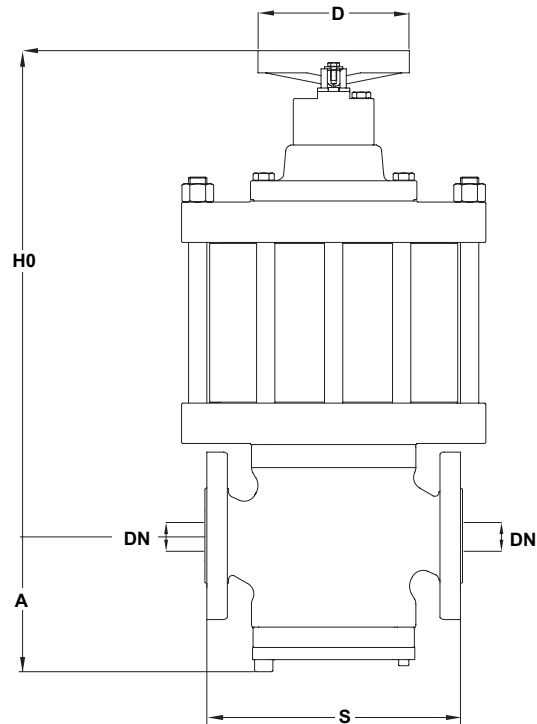
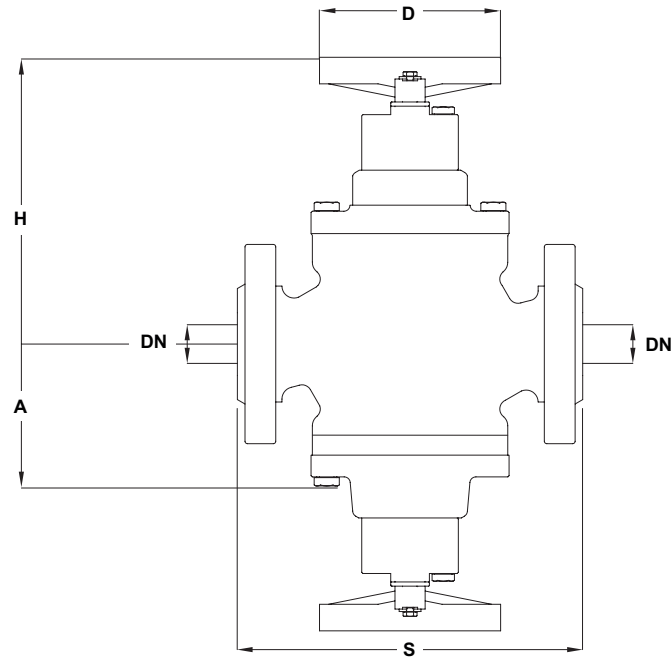

**Figure 8** VLM + DB/819 dimensions

Weights and Dimensions (for other connections please contact your nearest Pietro Fiorentini sales outlet)							
	[mm]   inches	[mm]   inches	[mm]   inches	[mm]   inches	[mm]   inches	[mm]   inches	[mm]   inches
Dimensions (DN)	25   1"	50   2"	65   2 1/2"	80   3"	100   4"	150   6"	200   8"
S - ANSI 150/PN16	183   7.20"	254   10"	276   10.87"	298   11.73"	352   13.86"	451   17.76"	543   21.38"
S - ANSI 300	197   7.76"	267   10.51"	-   -	317   12.48"	368   14.49"	473   18.62"	568   22.36"
S - ANSI 600	210   8.27"	286   11.26"	-   -	336   13.23"	394   13.23"	508   20"	609   23.98"
A	95   3.74"	130   5.12"	135   5.31"	150   1.97"	190   7.48"	250   9.84"	310   12.20"
D	150   1.97"	150   1.97"	150   1.97"	150   1.97"	150   1.97"	250   9.84"	250   9.84"
H	205   8.07"	240   9.45"	265   10.43"	270   10.63"	305   12.00"	420   16.54"	460   18.11"
H0	290   11.42"	480   18.90"	-   -	550   21.65"	620   24.41"	800   31.50"	900   35.43"
Tubing connections	eØ 10 x iØ 8 (on request imperial sizing)						
Weight	Kg   lbs	Kg   lbs	Kg   lbs	Kg   lbs	Kg   lbs	Kg   lbs	Kg   lbs
ANSI150/PN 16	43   95	97   214	74   163	146   322	196   432	432   952	692   1525
ANSI 300	46   101	100   220	-   -	152   335	236   520	448   987	735   1620
ANSI 600	47   103	102   225	-   -	156   344	242   533	487   1073	780   1720

**Table 5** Weights and dimensions

## VLM + PM

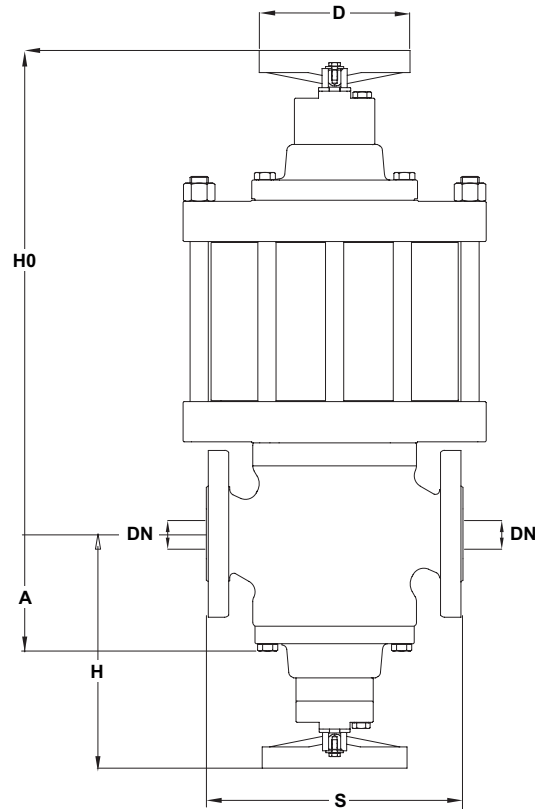

**Figure 9** VLM + PM dimensions

Weights and Dimensions (for other connections please contact your nearest Pietro Fiorentini sales outlet)							
	[mm]   inches	[mm]   inches	[mm]   inches	[mm]   inches	[mm]   inches	[mm]   inches	[mm]   inches
Dimensions (DN)	25   1"	50   2"	65   2"1/2	80   3"	100   4"	150   6"	200   8"
S - ANSI 150/PN16	183   7.20"	254   10"	276   10.87"	298   11.73"	352   13.86"	451   17.76"	543   21.38"
S - ANSI 300	197   7.76"	267   10.51"	-   -	317   12.48"	368   14.49"	473   18.62"	568   22.36"
S - ANSI 600	210   8.27"	286   11.26"	-   -	336   13.23"	394   13.23"	508   20"	609   23.98"
A	95   3.74"	130   5.12"	135   5.31"	150   1.97"	190   7.48"	250   9.84"	310   12.20"
D	150   1.97"	150   1.97"	150   1.97"	150   1.97"	150   1.97"	250   9.84"	250   9.84"
H	205   8.07"	240   9.45"	265   10.43"	270   10.63"	305   12.00"	420   16.54"	460   18.11"
Tubing connections	eØ 10 x iØ 8 (on request imperial sizing)						
Weight	Kg   lbs	Kg   lbs	Kg   lbs	Kg   lbs	Kg   lbs	Kg   lbs	Kg   lbs
ANSI150/PN 16	20   43	38   83	-   -	64   140	96   211	202   445	304   670
ANSI 300	22   47	40   87	-   -	65   142	116   255	212   467	319   703
ANSI 600	23   50	42   91	-   -	69   151	122   269	234   516	354   780

**Table 6** Weights and dimensions

## VLM + DB/819 + PM



**Figure 10** VLM + DB/819 + PM dimensions

Weights and Dimensions (for other connections please contact your nearest Pietro Fiorentini sales outlet)							
	[mm]   inches	[mm]   inches	[mm]   inches	[mm]   inches	[mm]   inches	[mm]   inches	[mm]   inches
Dimensions (DN)	25   1"	50   2"	65   2"1/2	80   3"	100   4"	150   6"	200   8"
S - ANSI 150/PN16	183   7.20"	254   10"	276   10.87"	298   11.73"	352   13.86"	451   17.76"	543   21.38"
S - ANSI 300	197   7.76"	267   10.51"	-   -	317   12.48"	368   14.49"	473   18.62"	568   22.36"
S - ANSI 600	210   8.27"	286   11.26"	-   -	336   13.23"	394   13.23"	508   20"	609   23.98"
A	95   3.74"	130   5.12"	135   5.31"	150   1.97"	190   7.48"	250   9.84"	310   12.20"
D	150   1.97"	150   1.97"	150   1.97"	150   1.97"	150   1.97"	250   9.84"	250   9.84"
H	205   8.07"	240   9.45"	265   10.43"	270   10.63"	305   12.00"	420   16.54"	460   18.11"
H0	290   8.07"	480   9.45"	-   -	550   10.63"	620   12.00"	800   16.54"	900   18.11"
Tubing connections	eØ 10 x iØ 8 (on request imperial sizing)						

Weight	Kg   lbs	Kg   lbs	Kg   lbs	Kg   lbs	Kg   lbs	Kg   lbs	Kg   lbs
ANSI150/PN 16	46   100	103   226	-   -	154   338	210   463	459   1012	732   1613
ANSI 300	49   107	106   233	-   -	160   352	250   551	475   1047	775   1709
ANSI 600	50   109	108   237	-   -	164   360	256   564	514   1133	820   1808

**Table 7** Weights and dimensions

## VLM + SB/82

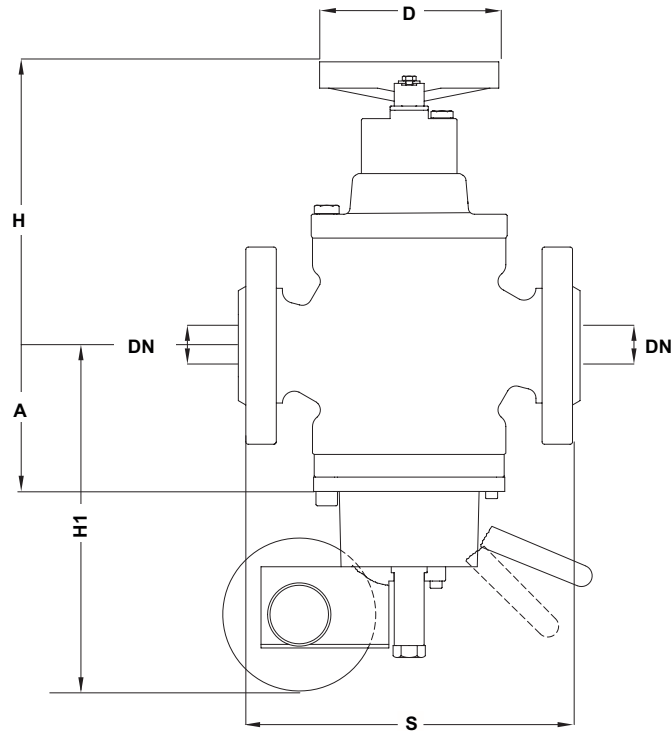
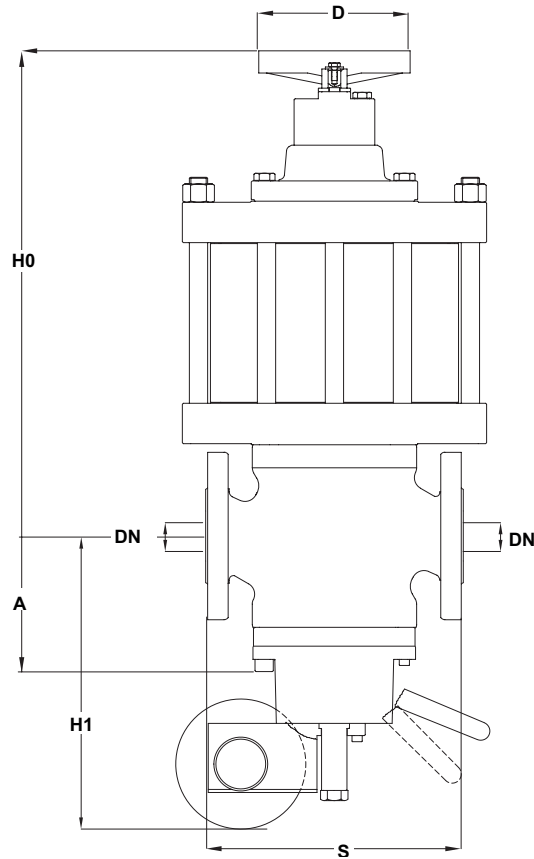

**Figure 11** VLM + SB/82 dimensions

Weights and Dimensions (for other connections please contact your nearest Pietro Fiorentini sales outlet)							
	[mm]   inches	[mm]   inches	[mm]   inches	[mm]   inches	[mm]   inches	[mm]   inches	[mm]   inches
Dimensions (DN)	25   1"	50   2"	65   2"1/2	80   3"	100   4"	150   6"	200   8"
S - ANSI 150/PN16	183   7.20"	254   10"	276   10.87"	298   11.73"	352   13.86"	451   17.76"	543   21.38"
S - ANSI 300	197   7.76"	267   10.51"	-   -	317   12.48"	368   14.49"	473   18.62"	568   22.36"
S - ANSI 600	210   8.27"	286   11.26"	-   -	336   13.23"	394   13.23"	508   20"	609   23.98"
A	95   3.74"	130   5.12"	135   5.31"	150   1.97"	190   7.48"	250   9.84"	310   12.20"
D	150   1.97"	150   1.97"	150   1.97"	150   1.97"	150   1.97"	250   9.84"	250   9.84"
H	205   8.07"	240   9.45"	265   10.43"	270   10.63"	305   12.00"	420   16.54"	460   18.11"
H1	215   8.46"	240   9.45"	-   -	270   10.63"	300   11.8"	400   15.7"	450   17.72"
Tubing connections	eØ 10 x iØ 8 (on request imperial sizing)						
Weight	Kg   lbs	Kg   lbs	Kg   lbs	Kg   lbs	Kg   lbs	Kg   lbs	Kg   lbs
ANSI150/PN 16	26   57	42   92	56   123	66   145	96   211	187   412	317   699
ANSI 300	29   64	45   99	-   -	70   154	118   260	205   452	335   738
ANSI 600	30   66	47   103	-   -	74   163	124   273	227   500	370   816

**Table 8** Weights and dimensions

## VLM + DB/819 + SB/82



**Figure 12** VLM + DB/819 + SB/82 dimensions

Weights and Dimensions (for other connections please contact your nearest Pietro Fiorentini sales outlet)							
	[mm]   inches	[mm]   inches	[mm]   inches	[mm]   inches	[mm]   inches	[mm]   inches	[mm]   inches
Dimensions (DN)	25   1"	50   2"	65   2 1/2"	80   3"	100   4"	150   6"	200   8"
S - ANSI 150/PN16	183   7.20"	254   10"	276   10.87"	298   11.73"	352   13.86"	451   17.76"	543   21.38"
S - ANSI 300	197   7.76"	267   10.51"	-   -	317   12.48"	368   14.49"	473   18.62"	568   22.36"
S - ANSI 600	210   8.27"	286   11.26"	-   -	336   13.23"	394   13.23"	508   20"	609   23.98"
A	95   3.74"	130   5.12"	135   5.31"	150   1.97"	190   7.48"	250   9.84"	310   12.20"
D	150   1.97"	150   1.97"	150   1.97"	150   1.97"	150   1.97"	250   9.84"	250   9.84"
H0	290   11.42"	480   18.90"	-   -	550   21.65"	620   24.41"	800   31.50"	900   35.43"
H1	215   8.46"	240   9.45"	-   -	270   10.63"	300   11.8"	400   15.7"	450   17.72"
Tubing connections	eØ 10 x iØ 8 (on request imperial sizing)						

Weight	Kg   lbs	Kg   lbs	Kg   lbs	Kg   lbs	Kg   lbs	Kg   lbs	Kg   lbs
ANSI150/PN 16	52   114	107   236	86   189	156   344	210   463	444   979	744   1640
ANSI 300	56   123	111   245	-   -	165   364	251   553	468   1032	790   1741
ANSI 600	57   125	113   249	-   -	169   372	257   566	507   1118	825   1819

**Table 9** Weights and dimensions



# Sizing and Cg

The regulator is usually chosen on the basis of the flow rate calculation determined through use of formulas and flow rate coefficients (Cg or KG), as indicated by Standard EN 334.

Flow coefficients							
Nominal dimensions	25	50	80	100	150	200	250
Inches	1"	2"	3"	4"	6"	8"	10"
Cg	575	2220	4937	8000	16607	25933	36525
K1	106.78	106.78	106.78	106.78	106.78	106.78	106.78

**Table 10** Flow coefficients

For sizing [CLICK HERE](#) or scan the QR code:



**Note:** If you do not already have access credentials, do not hesitate to contact your nearest Pietro Fiorentini representative.

In general, online sizing considers more variables as the valve is installed in a system, allowing a better, multi-perspective approach to sizing.

For gases other than natural gas; for natural gases with density other than 0.61, please apply the correction coefficients resulting from the following formula:

$$F_c = \sqrt{\frac{175.8}{S \times (273.16 + T)}}$$

S = Relative density at the air (see tab. 11)  
T = gas temperature ( °C )

### Corrective factors Fc

Gas type	Relative Density S	Corrective Factors Fc
Air	1.00	0.78
Propane	1.53	0.63
Butane	2.00	0.55
Nitrogen	0.97	0.79
Oxygen	1.14	0.73
Carbon dioxide	1.52	0.63

Note: The table indicates the Fc corrective factors valid for gas, calculated at a temperature of 15 °C and at the Declared relative density.

**Table 11** Corrective factors Fc

### Conversion of flow rates

$$\text{Stm}^3/\text{h} \times 0.94795 = \text{Nm}^3/\text{h}$$

Nm<sup>3</sup>/h reference conditions T= 0 °C; P= 1 barg  
Stm<sup>3</sup>/h reference conditions T= 15 °C; P= 1 barg

**Table 12** Conversion of flow rates

### ATTENTION:

For the purpose of obtaining optimal performance, preventing erosion phenomena and limiting the level of emitted noise, it is recommended that the velocity at the regulator outlet flange does not exceed the velocity indicated in the diagram provided below.

Gas velocity at the outlet flange can be determined with the following relation:

$$V = 345.92 \times \frac{Q}{\text{DN}^2} \times \frac{1 - 0.002 \times \text{Pd}}{1 + \text{Pd}}$$

V = gas speed in m/sec  
Q = gas flow rate in Stm<sup>3</sup>/h  
DN = nominal size of regular in mm  
Pd = outlet pressure in barg.

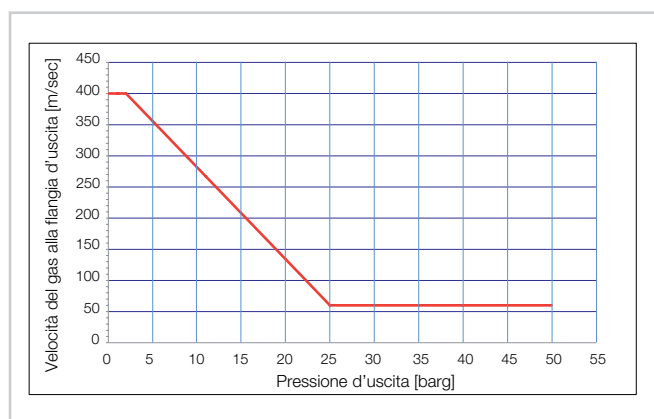



The choice of valve size is simplified by the use of the valve coefficient for gas  $C_g$  (table 10).

Flow coefficients at fully open position and various operating conditions are related by the following formulae where:

$Q$  = gas flow rate in  $\text{Stm}^3/\text{h}$

$P_u$  = inlet pressure in bar (abs)

$P_d$  = regulator outlet pressure in bar (abs).

- **A** > when both the  $C_g$  value of the valve and  $P_u$  and  $P_d$  are known, the flow coefficient can be calculated as follows:

- **A-1** under non critical conditions: ( $P_u < 2 \times P_d$ )

$$Q = 0.526 \times C_g \times P_u \times \sin \left( K_1 \times \sqrt{\frac{P_u - P_d}{P_u}} \right)$$

- **A-2** under critical conditions: ( $P_u \geq 2 \times P_d$ )

$$Q = 0.526 \times C_g \times P_u$$

- **B** > Vice versa, knowing the values of  $P_u$ ,  $P_d$  and  $Q$ , the required value of  $C_g$  or  $K_G$  is calculated and therefore the size of the regulator with:

- **B-1** under non critical conditions: ( $P_u < 2 \times P_d$ )

$$C_g = \frac{Q}{0.526 \times P_u \times \sin \left( K_1 \times \sqrt{\frac{P_u - P_d}{P_u}} \right)}$$

- **B-2** under critical conditions ( $P_u \geq 2 \times P_d$ )

$$C_g = \frac{Q}{0.526 \times P_u}$$

NOTES: The subject of the sen is in DEG.

# Installation

Below are some typical installations. On demand we are available to supply a more comprehensive experience list and/or references.

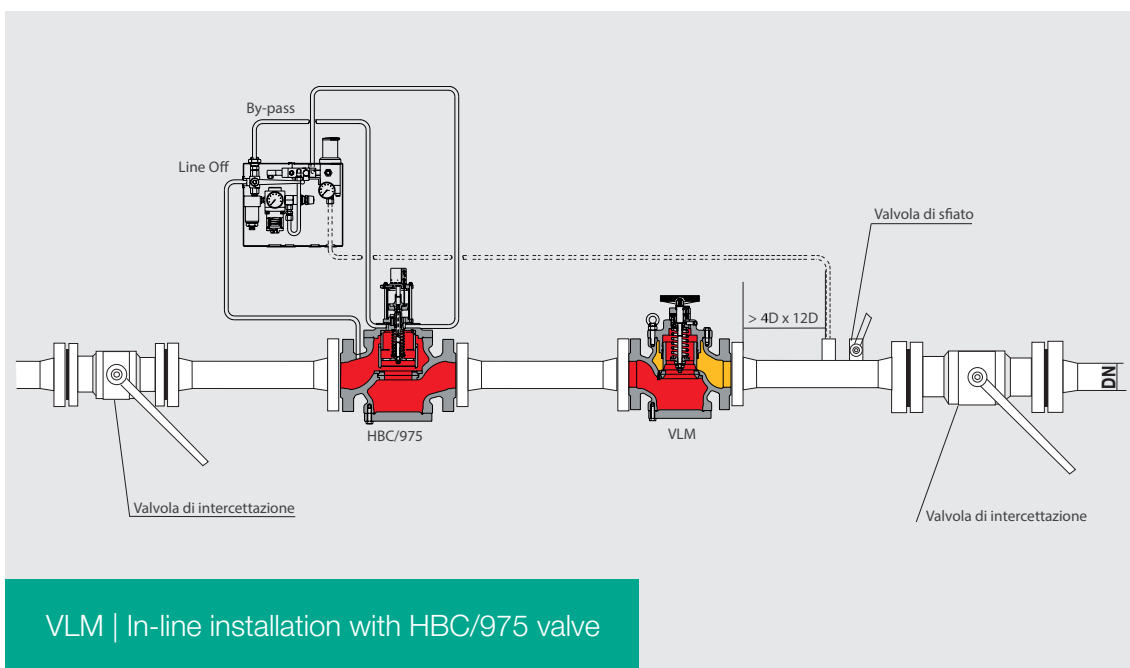
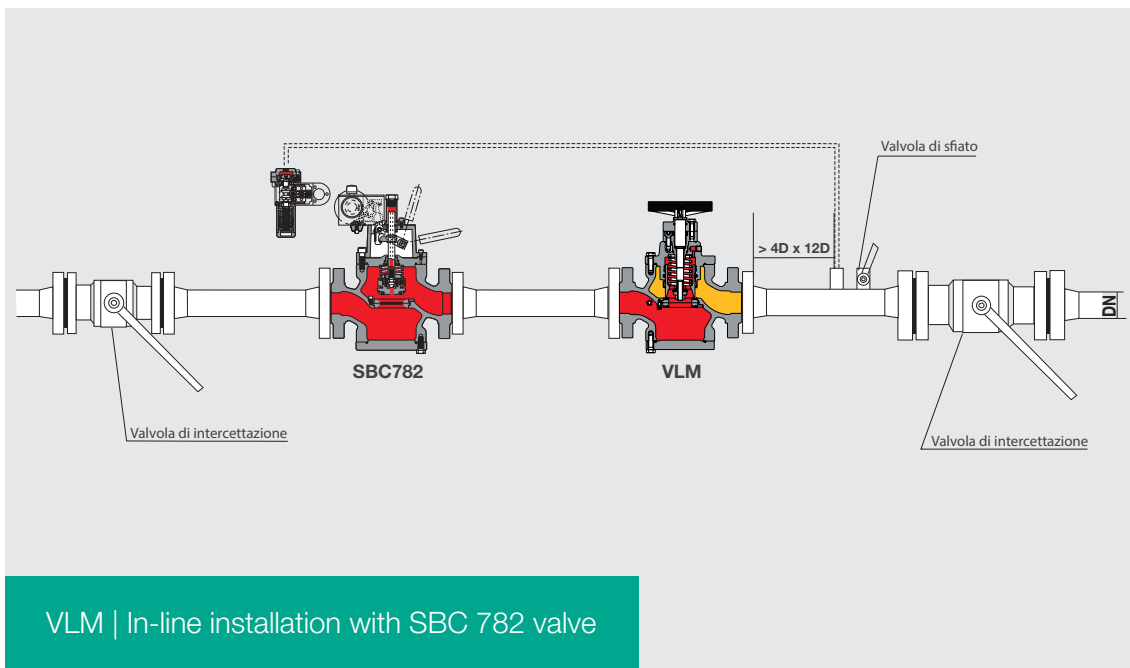



# Pietro Fiorentini

**TB0038ENG**



The data are approximate and not binding.  
We reserve the right to make changes without prior notice.

VLM\_technicalbrochure\_ENG\_revA

[www.fiorentini.com](http://www.fiorentini.com)